

**CIRCADIAN ORGANIZATION OF THE NEUROENDOCRINE
SYSTEM OF AN ADULT INSECT, *RHODNIUS PROLIXUS* (STÄL)
(HEMIPTERA)**

MICHAEL DAVID CARDINAL-AUCOIN

A DISSERTATION SUBMITTED TO THE FACULTY OF GRADUATE STUDIES
IN PARTIAL FULFILLMENT OF THE REQUIREMENTS FOR THE DEGREE OF

DOCTOR OF PHILOSOPHY

GRADUATE PROGRAM IN BIOLOGY
YORK UNIVERSITY
TORONTO, ONTARIO

MARCH, 2014

© Michael Cardinal-Aucoin, 2014

ABSTRACT

Circadian clocks synchronize with external environmental cycles and regulate rhythms throughout the organism, creating an internal temporal organization of cellular and physiological processes. In the model insect *Rhodnius prolixus* the prothoracicotropic hormone (PTTH)-ecdysteroid axis is a central component of the larval circadian system. However, PTTH is considered a larval hormone and its only known target, the ecdysteroid-producing prothoracic glands, are absent in adults. Here, PTTH is demonstrated to be present in adult female *Rhodnius* and its synthesis and release during the period of egg development and oviposition were shown to fluctuate with a daily rhythm that is controlled by the circadian clock in the brain. Ecdysteroids are also present during this time and their levels in hemolymph and ovaries undergo synchronous daily variations that are likewise under clock control. Ovaries are the only adult tissue examined that both contained and released ecdysteroids. It is inferred that the ovaries generate the rhythm of ecdysteroids in the hemolymph. The parallel patterns of PTTH and ecdysteroid release suggest these processes are related and it is tempting to speculate that the PTTH-ecdysteroid axis persists in the adult leading to the orchestration of complex adult-specific processes, such as egg development and oviposition.

DEDICATION

I dedicate this work to my parents who have always encouraged and supported me and whose unconditional love has made everything possible.

ACKNOWLEDGEMENTS

I would like to thank my supervisor, Dr. Colin Steel, for allowing me the opportunity to work on this project and without whom I would not be where I am today.

Thank you to my committee members, Drs. Barry Loughton and Andrew Donini, for their helpful comments throughout my time at York. Thank you also to Dr. Jean-Paul Paluzzi for joining the supervisory committee at the last minute.

Thank you to Dr. Xanthe Vafopoulou for all her help and guidance with laboratory techniques, experimental protocols, analysis, and for organizing lab get togethers with delicious food and wine.

Thank you to my labmates with whom I have shared the Steel Lab over the years and from whom I have learned so much: Kathy Terry, Jacob Scutaru, Adam Pauzé, Carolyn Arbanas, Martha Hindley-Smith, Tudor Saroiu, Nicholas Rapp, Sam Leung, Andrea Durant. A special thank you to Martha Hindley-Smith, Tudor Saroiu, Sam Leung, and Nicholas Rapp who have kept me company these last few years, especially during long overnight experiments.

Thank you to the Hilliker Lab, including Dr. Spencer Mukai, Rodrey Taylor, and Terry Hawryluk, for periodically lending us materials and flies.

Thank you to the Kelly Lab, including Dr. Helen Chasiotis, Phuong Bui, and Dennis Kolosov, for lending some materials and for use of some equipment.

Thank you to Phil Luck for help with photoshop and the final figure.

Thank you to the Biology graduate program assistant, Adrienne Dome, for all her hard work and help throughout my time as a graduate student at York.

This work was supported by Discovery Grant 6669 from the Natural Sciences and Engineering Research Council of Canada to CGHS.

TABLE OF CONTENTS

Abstract	ii
Dedication	iii
Acknowledgements	iv
Table of Contents	vi
List of Tables	xi
List of Figures	xii
List of Abbreviations	xiii
CHAPTER ONE: GENERAL INTRODUCTION	1
1 Time after time: An introduction to circadian rhythms	1
<i>1.1 About a day: The discovery of circadian rhythms</i>	<i>1</i>
<i>1.2 Circadian rhythms everywhere</i>	<i>4</i>
<i>1.3 Formal definition and properties of circadian rhythms</i>	<i>5</i>
<i>1.4 If I knew you were coming: circadian rhythms as an adaptation to a periodic environment.....</i>	<i>8</i>
2 Tick-tock: The molecular bases of circadian rhythms	12
<i>2.1 The insect molecular clockwork</i>	<i>12</i>
<i>2.2 The molecular clockwork in other organisms</i>	<i>18</i>
<i>2.3 Fine tuning: Post-translational and post-transcriptional mechanisms</i>	<i>20</i>
<i>2.4 Beyond the molecular oscillator</i>	<i>22</i>

3 Body clocks: Distribution of clocks in the organism	24
<i>3.1 Clocks in the central nervous system</i>	24
3.1.1 Insects	24
3.1.2 Molluscs.....	27
3.1.3 Fish.....	27
3.1.4 Birds.....	28
3.1.5 Mammals.....	29
<i>3.2 Clocks in the periphery</i>	31
3.2.1 Insects	32
3.2.2 Mammals.....	39
3.2.3 Other circa clocks	41
4 Circadian clocks in physiology	41
<i>4.1 Physiological significance of biological clocks</i>	42
<i>4.2 Clocks in the hypothalamo-pituitary-adrenal (HPA) axis</i>	45
<i>4.3 Measuring the days: Photoperiodism</i>	47
5 Endocrinology of insect development and reproduction	49
<i>5.1 Historical introduction</i>	49
<i>5.2 Prothoracicotropic hormone (PTTH)</i>	52
<i>5.3 Ecdysteroids</i>	55
<i>5.4 Juvenile hormone (JH)</i>	60
6 Circadian physiology of larval <i>Rhodnius</i>	63
<i>6.1 <i>Rhodnius</i>, a model organism in circadian physiology</i>	64

<i>6.2 Circadian organization of larval development of Rhodnius prolixus</i>	64
<i>6.3 Analogy with the mammalian system</i>	75
7 Objectives	77

CHAPTER TWO: RHYTHMIC RELEASE OF PROTHORACICOTROPIC HORMONE FROM THE BRAIN OF AN ADULT INSECT DURING EGG DEVELOPMENT		80
Prefix.....		81
Introduction.....		82
Materials and Methods.....		84
Results.....		89
Discussion.....		105

CHAPTER THREE: CIRCADIAN CONTROL OF PROTHORACICOTROPIC HORMONE IN AN ADULT INSECT AND THE INDUCTION OF RHYTHMICITY BY LIGHT CUES.....		112
Prefix.....		113
Introduction.....		114
Materials and Methods.....		116
Results.....		120
Discussion.....		130

CHAPTER FOUR: CIRCADIAN REGULATION OF HEMOLYMPH AND OVARIAN
ECDYSTEROIDS DURING EGG DEVELOPMENT IN THE INSECT *RHODNIUS*

<i>PROLIXUS</i> (HEMIPTERA)	137
Prefix.....	138
Introduction.....	139
Materials and Methods.....	140
Results.....	143
Discussion.....	154

CHAPTER FIVE: GENERAL DISCUSSION 161

1 The significance of circadian rhythms 161

2 Circadian rhythms in adult insects 161

3 Circadian organization of the neuroendocrine system in adult female

Rhodnius..... 164

3.1 The circadian clock in the brain..... 164

3.2 The clock in the brain controls rhythms of neuropeptides..... 167

*3.3 The ovaries release ecdysteroids into the hemolymph with a circadian
rhythm*..... 169

3.4 Potential hormonal interaction of brain and ovaries 174

4 Circadian organization of the neuroendocrine system in adult male

insects 179

5 Comparison with the mammalian system..... 180

6 General conclusions	183
7 Future directions	185
REFERENCES	186
1 Chapter 2	186
2 Chapter 3	196
3 Chapter 4	207
4 General references	219

LIST OF TABLES

Table 1:Ovaries contain high levels of ecdysteroids	147
---	-----

LIST OF FIGURES

Figure 1 [<i>Drosophila</i> molecular clockwork]	14
Figure 2 [Circadian system of larval <i>Rhodnius</i>]	66
Figure 3 [Brain clock network of larval <i>Rhodnius</i>]	72
Figure 4 [PTTH western blot].....	91
Figure 5 [Double immunoprecipitation of PTTH].....	94
Figure 6 [Egg development following a blood meal]	97
Figure 7 [Changes in PTTH content of adult brain complexes]	100
Figure 8 [Daily rhythm of PTTH release from adult brain complexes]	103
Figure 9 [Free running rhythms of PTTH release]	121
Figure 10 [Elimination of PTTH release by chronic exposure to LL]	124
Figure 11 [Reinitiation of rhythmic PTTH release by transfer to darkness]	126
Figure 12 [Western and dot blot analysis of PTTH in hemolymph].....	128
Figure 13 [Ecdysteroid levels during egg development]	145
Figure 14 [Daily rhythms of ecdysteroid levels]	149
Figure 15 [Free running rhythms of ecdysteroid levels].....	152
Figure 16 [Brain clock network of adult <i>Rhodnius</i>]	165
Figure 17 [Organization of the circadian neuroendocrine system of adult <i>Rhodnius prolixus</i>]	177

LIST OF ABBREVIATIONS

20E	20-Hydroxyecdysone
AANAT	arylalkyl <i>N</i> -acetyltransferase
ACTH	Adrenocorticotropic hormone
AMe	Accessory medulla
AST	Allatostatin
ARNTL	Aryl hydrocarbon receptor nuclear translocator-like protein
<i>arntl</i>	Aryl hydrocarbon receptor nuclear translocator-like gene
bHLH-PAS domain	Basic helix-loop-helix-Per, Arnt, Sim domain
BMAL1	Brain and muscle aryl hydrocarbon receptor nuclear translocator (ARNT)-like protein
<i>bmal1</i>	Brain and muscle aryl hydrocarbon receptor nuclear translocator (ARNT)-like gene
CAP	Compound action potential
CCAP	Crustacean cardioactive peptide
CK1	Casein kinase 1
CK2	Casein kinase 2
CLK	CLOCK protein
<i>clk</i>	<i>clock</i> gene
CRY	CRYPTOCHROME protein
CYC	CYCLE protein
<i>cyc</i>	<i>cycle</i> gene
DAB	3,3'-Diaminobenzidine
DABCO	1,4-diazabicyclo[2.2.2]octane
DAPI	4',6-diamidino-2-phenylindole
DN	Dorsal clock neuron
E	Ecdysone
EcR	Ecdysteroid receptor
FSH	Follicle stimulating hormone
GR	Glucocorticoid receptor
ILP	Insulin-like peptide
JH	Juvenile hormone
JHBP	Juvenile hormone binding protein
LH	Luteinizing hormone
LN	Lateral clock neuron
MR	Mineralocorticoid receptor
OEH	Ovary ecdysteroidogenic hormone
PDF	Pigment dispersing factor
PDH	Pigment dispersing hormone
PER	PERIOD protein
<i>per</i>	<i>period</i> gene
PG	Prothoracic gland
PP2	Protein phosphatase 2

PPA	Primary protocerebral arborization area
PTTH	Prothoracicotropic hormone
RIA	Radioimmunoassay
RHT	Retino-hypothalamic tract
SDS	Sodium dodecylsulphate
SCN	Suprachiasmatic nuclei
StAR	Steroidogenic acute regulatory protein
<i>Start1</i>	<i>Star-related lipid transfer domain 1</i> gene
TE	Testes ecdysiotropin
TIM	TIMELESS protein
<i>tim</i>	<i>timeless</i> gene
TTFL	Transcription-translation feedback loop
USP	Ultraspiracle protein
VG	Vitellogenin

CHAPTER ONE GENERAL INTRODUCTION

1. TIME AFTER TIME: AN INTRODUCTION TO CIRCADIAN RHYTHMS

"A rose is not necessarily and unqualifiedly a rose; that is to say, it is a very different biochemical system at noon and at midnight." (Colin Pittendrigh, 1993)

1.1 About a day: The discovery of circadian rhythms

Rhythmic natural phenomena have been observed for millennia. The fact that some animals are active during the day and others at night would have been noticed by early humans contemplating the temporal order of nature. The first written records of the daily cycles displayed by plant leaves and flowers date back to around the 4th century B.C.E. Androstenes of Thasos, admiral of Alexander the Great, reported that the Tamarind tree opened its leaves during the day and closed them at night (Moore-Ede et al., 1982). Around the same time Aristotle wrote:

"In the bee the fact of its being asleep is very obvious; for at night-time bees are at rest and cease to hum. But the fact that insects sleep may be very well seen in the case of common every-day creatures; for not only do they rest at night-time from dimness of vision (and, by the way, all hard-eyed creatures see but indistinctly), but even if a lighted candle be presented they continue sleeping quite as soundly".

However, further investigation of these natural rhythms was delayed because of their seemingly simple and obvious explanation: the plants and animals were merely responding to the rising and setting of the sun.

The first scientific study of biological rhythms was undertaken by the French astronomer Jean-Jacques d'Ortous de Mairan. He noted that the leaves of the *Mimosa* plant (la 'sensitive') were upright during the day and drooped at night. In 1729, he performed an experiment in which he placed a *Mimosa* in a dark cupboard and inspected it regularly for the next several days. He reported that even in isolation from the sunlight the rhythmic movements of the plant leaves continued day after day and concluded that: "La sensitive sent donc le soleil sans le voir en aucune manière" (de Mairan, 1729). De Mairan's results suggested that the natural rhythms that had been observed for generations were not simple reactions of the organism to the cycle of light and darkness and that they might have a more subtle and profound cause. It was nearly 30 years before de Mairan's observations were independently confirmed (Hill, 1757; Duhamel du Monceau, 1758; Zinn, 1759). These authors additionally excluded the possibility that variations in temperature were driving the rhythmic motion of the leaves, in some cases by rather extreme methods. In 1758, for example, Duhamel du Monceau lowered some plants to the bottom of a salt mine where they would be in constant darkness and constant temperature. The plant leaves continued to move rhythmically even in these conditions and he concluded: "que les mouvements de la sensitive ne dépendent point essentiellement ni de la lumière, ni de la chaleur" (Duhamel du Monceau, 1758). In the early 1800's, the Swiss botanist Augustin Pyramus de Candolle corroborated and extended previous findings. De Candolle (1832) exposed plants to constant light and constant darkness, he heated plants, and he submerged them in water. In every case the leaf rhythms persisted. De Candolle noticed that when the plants were placed in constant

conditions the period of the rhythm was slightly shorter than 24 hours. This is an important observation since if the rhythm was due to some external cue, such as the light/dark (LD) cycle, one would expect a period of exactly 24 hours. Furthermore, De Candolle switched some plants from the regular LD cycle to a reversed LD cycle. He observed that after a few days of irregular rhythms the leaf movements adjusted to the new light cycle and opened their leaves when it was actually dark outside! De Candolle supposed "que les mouvements du sommeil et du réveil sont liés à une disposition de mouvements périodiques inhérente au végétal, mais qui est essentiellement mise en activité par l'action stimulante de la lumière" (de Candolle, 1832). These findings further support the notion that these biological rhythms are not just responses to an external force and that they somehow originate within the organism. Charles Darwin and his son Francis briefly studied the rhythmic motion of plant leaves and became convinced of their endogenous nature and suggested that "the periodicity... is to a certain extent inherited" (Darwin and Darwin, 1880). Additionally, Darwin proposed that these movements may be adaptive by minimizing heat loss at night and fully exposing the leaf surface for photosynthesis during daylight. De Mairan's phenomenon was finally confirmed in animals toward the end of the 19th century: first in insects when the Viennese physiologist Kiesel (1894) described the daily migration of retinal pigment in moths and then in mammals when Simpson and Galbraith (1905) reported a rhythm of body temperature in squirrel monkeys. In 1959, Franz Halberg coined the word *circadian* to describe these daily rhythms from the Latin 'circa', meaning about, and 'diem', meaning a day (Halberg, 1959) to emphasize the salient feature of these rhythms.

1.2 Circadian rhythms everywhere

The study of the daily movements of plant leaves and flowers contributed significantly to the early development of the field of biological timekeeping or chronobiology. Rhythmic movements and behaviours were among the first to be investigated since they were the more conspicuous, such as the obvious sleep-wake cycle of most mammals, including humans. Endogenous 24 hour rhythms have now been reported in representatives of all the major divisions of life including Archaea (Whitehead et al., 2009), bacteria (Johnson et al., 2008), protozoans (Driessche, 1994), fungi (Dunlap and Loros, 2006), plants (McLung, 2006; Harmer, 2009), and animals (Harker, 1958) and at all levels of biological organization from molecular to organismal and from physiological to behavioural (Roenneberg and Mellow, 1999). There has even been a report of a daily rhythm of viral replication, though this is likely attributed to the intrinsic circadian rhythm of replication activity of the host cell (Swain et al., 1995).

Circadian rhythms have been documented at the transcriptional and translational levels and in some cases these have been found to form part of the endogenous molecular mechanism responsible for the rhythms (Hardin, 2009). At a higher level of biological organization, rhythms have been described in numerous physiological parameters, such as hormone levels and core body temperature. At the level of the whole organism, rhythms of behaviour in animals and of leaf and flower opening in plants have been observed in numerous species. Rhythms in behaviour synchronize the species' population and influence processes at the community and ecosystem levels. Certain rhythms were particularly amenable to experimentation and analysis, such as the conidiation rhythm of

the fungus *Neurospora crassa* (Nakashima and Onai, 1996), the activity rhythm of mice and cockroaches, and the eclosion rhythm of the fly *Drosophila pseudoobscura*. Several circadian rhythms have been well characterized in a variety of unicellular eukaryotic organisms including *Euglena spp.*, *Acetabularia spp.*, *Gonyaulax polyedra* (now *Lingulodinium polyedrum*), (Driessche, 1994; Roenneberg, 1996) and *Chlamydomonas reinhardtii* (Iliev et al., 2006; Schulze et al., 2010). Circadian control of metabolism was recently demonstrated in the yeast *Saccharomyces cerevisiae* (Eelderink-Chen et al., 2010). The ubiquity of circadian rhythms highlights their vital importance in biological systems. Thus, Pittendrigh (1960) remarked that circadian rhythms are more than mere “secondary adaptations superficial to the main physiological architecture of the organism,” rather they are “inherent in and pervade the living system to an extent that they are fundamental features of its organization.”

1.3 Formal definition and properties of circadian rhythms

By the first half of the 20th century some scientists, including Erwin Bünning, Jürgen Aschoff, and Colin Pittendrigh had initiated rigorous and focused research programs to investigate the properties of biological rhythms. The rapid accumulation of experimental results and observations allowed the development of hypotheses regarding the biological bases of the endogenous daily rhythms. The 1959 Cold Spring Harbour meeting on Circadian Rhythms did much to unite the field and elevate the study of biological rhythms from esoteric curiosity to legitimate scientific endeavour. It was at this meeting that Pittendrigh (1960) presented his list of “empirical generalizations” to

summarize the characteristic properties of circadian rhythms and provide direction to the emerging field of chronobiology.

Circadian rhythms are defined as those daily rhythms that persist in constant (aperiodic) conditions (i.e. they are endogenous; Generalization III) with a free running period length (τ) of around 24 hours (Generalization I) that is temperature compensated (Generalization XI). Most biological systems have a temperature coefficient (Q_{10}) of around 2-3, that is they roughly double with every 10° C increase in temperature. τ has a Q_{10} close to 1. However, the temperature compensation of circadian rhythms remains poorly understood (Bodenstein et al., 2012). An important feature of circadian rhythms is their ability to be synchronized by periodic signals (Generalization XIII). Any such periodic signal or zeitgeber (literally 'time giver') that causes the rhythm to assume a stable phase relationship with the zeitgeber is said to entrain it. The most common zeitgebers are those that emerge from the rotation of the earth, most notably the alternation of light and darkness. There are other geophysical cycles capable of entraining circa-rhythms on other timescales, such as the lunar cycle (circa-lunar and circa-semilunar), the rhythmic tides (circa-tidal), and the revolution of the Earth around the Sun (circannual). These rhythms are much less well studied and consequently less well understood than circadian rhythms. For circadian rhythms, entrainment by light is the dominant pattern across organisms. Indeed the alternation of light and darkness provides the most precise and potent signal as a cue to time of day. Nonetheless, entrainment by other modalities has also been established. Entrainment by temperature cycles became known in plants and poikilotherms, but eventually also in homeothermic mammals such

as the squirrel monkey (Aschoff and Tokura, 1986). Other periodicities capable of entraining the circadian systems are for instance barometric pressure in pocket mice, *Perognathus longimembris* (Hayden and Lindberg, 1969), periodic conspecific song in songbirds (Gwinner, 1966), and social interaction (Bloch et al., 2013b). It is now accepted that feeding time (Stephan, 2002; Mendoza, 2006) and internal hormone rhythms (Vafopoulou and Steel, 2009; Kalsbeek and Fliers, 2013) can also act as zeitgebers in some cases.

The process of entrainment was studied using the so-called 'black box' approach in which a system of unknown composition is perturbed and the consequence is observed in order to make inferences about the system. Although indirect, this method provided much valuable information that, along with other findings, led Pittendrigh (1958) to propose the concept of Endogenous Self-Sustained Oscillators (ESSOs) (Pittendrigh, 1958) as a model for the biological basis of circadian rhythms. Another method employed to probe the inner workings of the circadian oscillator relied on the fact that circadian rhythms can be phase shifted by single perturbations in the light regime (Generalization XIV). Phase shifts can also be produced by other factors including temperature and chemicals. The magnitude and direction of the phase shift depends on when during the circadian cycle the perturbation occurs. Plotting a series of phase shifts for a given rhythm produces what is referred to as a phase response curve (PRC). The first such PRCs were published for the pupal eclosion rhythm of *Drosophila pseudoobscura* (Pittendrigh, 1958) and the daily activity rhythm of two flying squirrels, *Glaucomys volans* (DeCoursey, 1960). Soon, 100's of PRCs were performed on a wide variety of

species (Johnson, 1999), including humans (Honma and Honma, 1988; Khalsa et al., 2003). PRCs for brief light pulses are universally characterized by phase delays during part of the circadian cycle and phase advances during another part. This property ensures that during entrainment to the day/night cycle in the natural environment, light will shift circadian rhythms appropriately to maintain a proper phase relationship and therefore the PRC for light reflects an excellently functional property, common to all circadian systems, which keeps life in synchrony with the rotation of the earth (Johnson, 1999).

1.4 If I knew you were coming: circadian rhythms as an adaptation to a periodic environment

"Those who live by the clock live to be old." (Georg Christoph Lichtenberg, 1793)

The ubiquity of circadian rhythms suggests they must impart a significant evolutionary adaptive advantage to the organisms that display them. It can also be argued that the complexity of the mechanisms involved (see Section 2) is evidence of adaptive value. Further, the very fact of their evolution is proof in itself. However, experimental evidence for the adaptive value of circadian clocks has not always been forthcoming. Nevertheless, a variety of different types of evidence exist supporting the adaptive role of circadian rhythms and circadian clocks (Vaze and Sharma, 2013). It is believed that circadian clocks confer fitness advantage to their owners by providing both extrinsic and intrinsic adaptive value (Vaze and Sharma, 2013). Extrinsic adaptive value arises from the ability of circadian clocks to synchronize behavioural and physiological processes to the external environment, while intrinsic adaptive value is derived from the coordination of internal cellular and biochemical events into the ordered sequences that are necessary

for life. A third way circadian clocks might be advantageous to organisms is through their responses to seasonal variation (i.e. photoperiodism; see Section 3.4).

The extrinsic adaptive value of circadian clocks is illustrated by the ability of organisms to predict periodic environmental events and prepare for them. Prior to waking from sleep each morning blood pressure begins to elevate, blood glucose levels increase, and core body temperature rises. Thus, the circadian system anticipates the increased energetic demands of morning activity and prepares in advance. In plants and other photosynthetic organisms, circadian clocks regulate the timing of the photosynthetic machinery in anticipation of sunrise.

Several recent studies have demonstrated the extrinsic value of circadian clocks. Circadian clocks can allow their possessors to predict the rhythmic behaviour of other organisms. As sure as night follows day, the caterpillar *Trichoplusia ni* eats during the day and rests at night. The plant *Arabidopsis thaliana*, thale cress, was found to increase its production of jasmonate, a compound that acts as a defence against insect herbivores, in phase with the *T. ni* feeding rhythm (Goodspeed et al., 2012). Additionally, when these plants and insects were entrained to the same light regime the caterpillars consumed significantly less than when they were out of phase with each other (Goodspeed et al., 2012). Therefore, the plant circadian clock provides a strong physiological advantage by performing a critical role in timing *Arabidopsis* defence.

Numerous studies have shown that circadian rhythms tend to match the photoperiodic environment of the organism (Yerushalmi and Green, 2009). An elegant experiment by Ouyang et al. (1998) clearly demonstrated the importance of a close match

between the endogenous circadian period and that of the environment. They mixed circadian clock mutants of the cyanobacteria *Synechococcus elongatus* with different circadian periods and studied their fate in LD cycles with different periods. They found that the mutant with the closest match between internal and external time always outcompeted the others and survived (Ouyang et al., 1998). More recently, O'Donnell et al. (2011) provided a simple test of the adaptive significance of circadian rhythms by rearing the rodent malaria parasite *Plasmodium chabaudi* in either 12 hours light: 12 hours dark or the reverse and then transferring them to new hosts entrained to the opposite light regime. They found that parasites that were entrained to the opposite light cycle as their host suffered a twofold reduction in the production of replicating and transmission stages of the parasite. Their results provide a clear demonstration of the adaptive value of circadian rhythms.

If circadian clocks provide such an advantage then what happens to an organism from which the clock has been removed? DeCoursey et al. (2000) lesioned the brain clock (SCN; see Section 3) of a group of chipmunks and released them into the wild. They found that a significantly higher proportion of clock-less chipmunks succumbed to predation as compared to control animals and attributed this fact to increased 'inappropriate' activity during the night time.

The intrinsic advantage of circadian clocks to the health of organisms is evident from the consequences of circadian dysregulation. For example, clock gene knockouts in insects can cause reduced reproductive fitness (Beaver et al., 2002; Tobback et al., 2011) and reduced lifespan (Pittendrigh and Minis, 1972). Additionally, disrupting the circadian

system by exposure to constant light or to non-circadian light regimes has been shown to cause impaired growth of plants (Went, 1960) and premature death in insects (Pittendrigh and Minis, 1972). In humans, there is an increased incidence of health problems including depression, diabetes, and cancer in human shift workers and frequent sufferers of jetlag (Knuttsen, 2003; Rudiger, 2004; Haus and Smolensky, 2013). Observations such as these further demonstrate the degree to which circadian clocks are an integrated and essential part of our biology.

Circadian clocks also participate in photoperiodic phenomena (see Section 4.1) by allowing organisms to measure seasonal changes in day length. Thus, important events can be restricted to the appropriate time of year. For example, entrance into and emergence from diapause in insects, reproduction in mammals, and the opening of leaf buds and flowers in plants must coincide with particular seasons and often must be synchronized with conspecifics or survival will be reduced dramatically. The fitness value of photoperiodic responses has been demonstrated using populations of pitcher plant mosquitoes, *Wyeomyia smithii*, derived from different latitudes ranging from 30 to 50° N (Bradshaw et al., 2004). All the mosquitoes were maintained experimentally in photic conditions mimicking those at 40° N (mid-latitude). Both the northern and southern populations suffered severe reductions in fitness as a result of entering diapause too early or too late, respectively. The mid-latitude populations experienced no loss in fitness. Therefore, latitudinally appropriate photoperiodic responses contribute to the fitness of organisms by enhancing their adaptation to seasonal changes in the photic environment.

2. TICK-TOCK: THE MOLECULAR BASES OF CIRCADIAN RHYTHMS

"Why this absurd concern with clocks, my friend?" (Walter de la Mare, "The Winged Chariot")

The molecular clockwork that generates circadian rhythms has been worked out in a number of model organisms representing a variety of taxa. A common feature in the design of the circadian oscillators of these organisms is the use of transcription-translation feedback loops (TTFLs) involving the interaction of positive and negative elements (Bell-Pedersen et al., 2005). These TTFLs therefore appear to be an ancient and well conserved feature of circadian clocks and it is believed that the different molecular oscillators in different taxa arose from multiple evolutionary origins (Rosbash, 2009), highlighting the fitness advantage provided by such a system. In many of these oscillators, the positive elements of the loop activate the transcription of so-called 'clock genes' that encode the negative elements of the system. As a result, the concentrations of the negative elements rise, and they physically interact with the positive elements to inhibit their activity. This inhibition reduces transcription of the genes that encode the negative elements. The degradation of the negative elements (often associated with phosphorylation) decreases their concentrations, which leads to reactivation of the positive elements, allowing the cycle to start again. The negative elements also activate the expression of one or more of the positive elements to form interlocking positive and negative-feedback loops that are thought to be important for maintaining the stability and robustness of the oscillator.

2.1 The insect molecular clockwork

Work in the fruit fly *Drosophila melanogaster* provided the first insights into the molecular mechanisms that generate circadian rhythms. Konopka and Benzer (1971) described three clock mutants in *Drosophila melanogaster*, the first clock mutants to be described in any organism. The mutations affected the population level eclosion rhythm and the locomotor rhythm of individual flies. One mutant strain was completely arrhythmic, another had a shortened period length and the third had a longer period length compared to wild type flies. Fortuitously, all three mutations were traced to the same gene on the X chromosome (Konopka and Benzer, 1971), which was therefore called the period (*per*) gene. The product of the *per* gene, PER, is now known to be a basic helix-loop-helix (bHLH) protein and contains two PAS (PER-ARNDT-SIM) protein-protein interaction motifs, two other C-terminal alpha helices likely involved in interprotein interactions, nuclear localization and export signals, and sites for post-translational modifications (e.g. phosphorylation) (Hardin, 2009). The PAS domain (named for the three *Drosophila* genes PER, ARNT, SIM) mediates protein-protein interaction and was one of the first common elements recognized between insects and mammals; DNA binding domains and sequences controlling cytoplasmic or nuclear localization are also conserved. Based partly on the observation that the phase of PER protein cycling always lagged behind that of *per* mRNA, Hardin et al. (1990) proposed that the clock genes and their products generated circadian rhythms via an autoregulating transcription-translation feedback loop in which the protein product of a gene eventually inhibits its own transcription. The *Drosophila* molecular oscillator (Fig. 1) has now been

Figure 1: The molecular clockwork of *Drosophila melanogaster* (from Tomioka et al., 2012). For details see text.

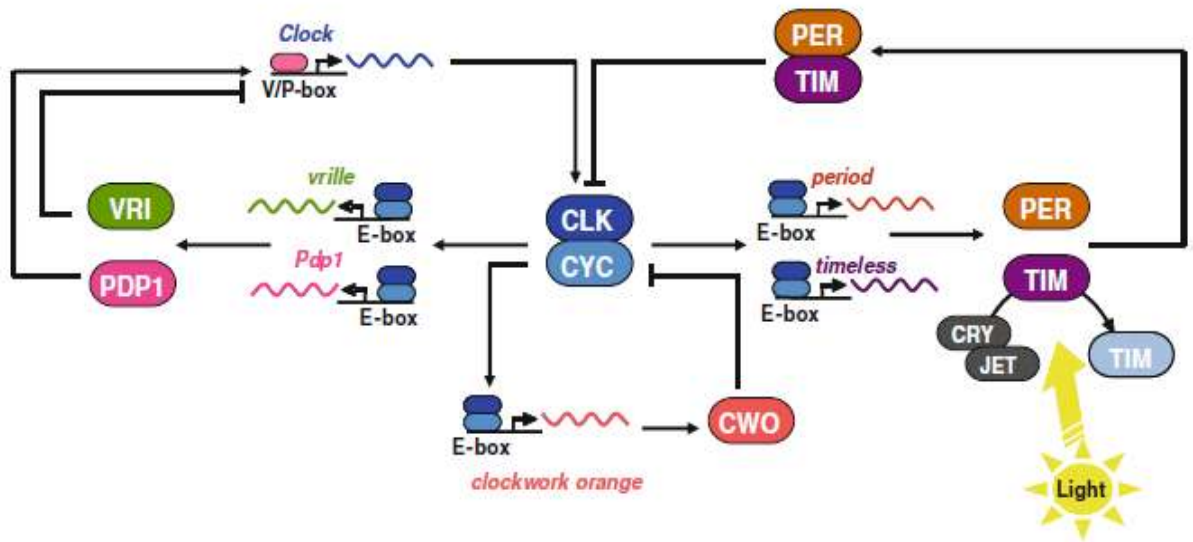

shown to consist of at least 3 interlocking TTFLs and involves several dozen genes and proteins (Hardin, 2009).

One major loop is formed by the *per*, *timeless* (*tim*), *clock* (*clk*), and *cycle* (*cyc*) genes and their protein products. The *clock* (Circadian Locomotor Output Cycles Kaput) gene was first identified via a landmark forward mutagenesis screen in the mouse, followed by positional cloning (Vitaterna et al., 1994; King et al., 1997). A close homolog of similar function exists in *Drosophila* (Allada et al., 1998). In *Drosophila*, the proteins CLOCK (CLK) and CYCLE (CYC) heterodimerize and bind to a promoter region, called an E-box, of the *period* (*per*) and *timeless* (*tim*) genes leading to the translation of PER and TIM proteins. The *tim* gene was discovered in *Drosophila* (Sehgal et al., 1994) and its protein product, TIM, heterodimerizes with PER and is required for the nuclear localization of PER (Sehgal et al., 1994; Vosshall et al., 1994). Once in the nucleus, the PER/TIM heterodimer represses *per* and *tim* transcription by inhibiting the action of CLK/CYC. Gradually the levels of PER and TIM are reduced by degradation which eventually releases CLK/CYC from the repression and allows it to reactivate the transcription of *per* and *tim*. This reactivation leads the loop to the next round.

A second loop is linked to the first by the CLK/CYC heterodimer. CLK/CYC also activates transcription of *vri* (*vri*) and PAR domain protein 1 ϵ (Pdp1 ϵ). The *vri* mRNA is rapidly translated to its protein product VRI, which enters the nucleus and inhibits transcription of *Clk* by binding to a promoter region, called the V/P-box. The translation of Pdp1 ϵ occurs more slowly and the PDP1 ϵ protein is believed to bind to the V/P-box and compete with VRI to activate *Clk* transcription. In turn, the transcription of both

PDP1 and *vriille* is activated by the CLK/CYC heterodimer (Cyran et al., 2003). This feedback loop regulates the rhythmic expression of *Clk*.

The third loop was discovered more recently and involves the clockwork orange (*cwo*) gene, which is rhythmically expressed under the regulation of CLK/CYC and forms its own negative feedback loop (Kadener et al., 2007). The CWO protein acts through E-box elements to repress transcription of other clock genes, such as *per* and *tim*. This negative feedback loop is believed to contribute to sustaining high-amplitude circadian oscillations.

In *Drosophila*, TIM is involved in the light input pathway to the circadian oscillator. TIM is rapidly reduced by light (Hunter-Ensor et al. 1996) through its interaction with the blue light sensing protein CRYPTOCHROME (CRY). In insects, the importance of TIM to the circadian oscillator remains unquestioned and its interaction with PER is important both for PER nuclear localization as discussed earlier, and for the modification of PER by casein kinase 2 (Meissner et al., 2008). The cryptochrome proteins are homologous to blue-light photoreceptors of bacteria and plants and in *Drosophila* these proteins clearly carry out at least two functions: on the one hand, they act as blue-light photoreceptors that mediate the light-dependent degradation of the TIM protein (Stanewsky et al., 1998; Ceriani et al., 1999) and on the other, they act as direct or indirect transcriptional repressors that play a necessary light independent role in the circadian clockwork (Krishnan et al., 2001). Finally, tangential to their clock roles, insect CRY proteins also play an important role in sun-compass navigation and magnetosensitivity (Gegear et al., 2008; Zhu et al., 2008).

2.2 The molecular clockwork in other organisms

Numerous mammalian homologues of insect clock genes and proteins have been identified, indicating conservation of the core molecular clockwork between insects and mammals (reviewed by Glossop, 2011). The conservation of sequences and functions of many clock genes from *Drosophila* and other insects to mammals, establishes insects as key model systems for understanding circadian clocks in mammals, including humans. In mammals, these genes and proteins are organized into two major interlocking feedback loops (reviewed by Ko and Takahashi, 2006). In mammals, heterodimers of CLOCK/BMAL1 (homologue of *Drosophila* CYC) activate transcription of the *Period* (*Per*; of which there are three in mammals) and *Cryptochrome* (*Cry*; of which there are 2 in mammals) genes. In some mammalian tissues, a second CLOCK-like protein termed NPAS2 is also present (Reick et al., 2001). In mammals, cryptochromes replace TIM as the partner of PER and the PER/CRY heterodimer interacts with the CLOCK heterodimers to inhibit their own transcription (Ko and Takahashi, 2006). The role of TIM in the mammalian circadian oscillator remains debated. Therefore, cryptochrome does not act as a photoreceptor in mammals but rather plays an essential role in the inherent mechanism of the circadian oscillator (van der Horst et al., 1999), and specifically in transcriptional repression (Kume et al., 1999). In recent years, a second cryptochrome (CRY2) was identified in some insects (Zhu et al., 2005; Yuan et al., 2007) that possesses characteristics of its mammalian counterpart. In these insects, CRY2 is not light sensitive and plays a transcriptional repressive function within the molecular clockwork. In fact, the honey bee genome does not encode an ortholog of *Drosophila tim*

and has only the mammalian type *cry2* (Rubin et al., 2006). Therefore the clockwork of honeybees and other insects may resemble that of mammals more closely than it does that of *Drosophila*.

Additionally, CLOCK/BMAL1 activate and PER and CRY inhibit the transcription of REV-ERB α , a member of the retinoic acid orphan receptor (ROR) family. REV-ERB α inhibits *Bmal1* transcription while another ROR protein, Rora, activates it, thereby linking the two limbs of the transcription-translation feedback loops (Ko and Takahashi, 2006).

In mammals, the period gene *Per1* (and possibly *Per2*) is acutely induced by light in the central brain clock in the suprachiasmatic nucleus (SCN) (see Sect. 2.5.1), and probably plays a role in the input of light into the circadian molecular circuit (Albrecht et al., 1997; Shearman et al., 1997). *Per* genes are also induced in cells by a variety of stimuli (e.g. serum shock, hormones) that reset the circadian oscillator, and therefore are likely to play a role in clock synchronization at all systemic levels (Balsalobre et al., 1998, 2000). In humans, a familial mutation mapped to the *Per2* gene causes Familial Advanced Sleep Phase Syndrome, a disease characterized by short circadian period and early behavioral phase (Toh et al., 2001).

The core circadian oscillator of non-metazoan organisms such as fungi, plants, and bacteria does not appear to share any homologous genes or proteins with that of insects or mammals, though the general principle of the TTFL is still observed. The fungus *Neurospora crassa* displays an easily observable circadian rhythm of conidiation (Pittendrigh et al., 1959) that has facilitated the elucidation of the underlying circadian

molecular machinery (reviewed by Baker et al. 2012). In *Neurospora*, the core oscillation occurs in two major steps (Merrow et al., 1997) and involves the heterodimeric positive element composed of proteins encoded by the *white collar (wc)-1* and *wc-2* genes (Crosthwaite et al., 1997) and the negative element which consists of either of two forms of the FREQUENCY (FRQ) protein (Aronson et al., 1994; Garceau et al., 1997).

The circadian system of plants has been primarily investigated using the model organism *Arabidopsis thaliana*. Recent experimental and mathematical evidence suggests that the plant circadian clock consists of three interlocked transcriptional feedback loops (reviewed by Harmer, 2009) involving the clock genes *Timing of cab expression 1 (TOC1)*, *CIRCADIAN CLOCK ASSOCIATED 1 (CCA1)*, *LATE ELONGATED HYPOCOTYL(LHY)*, and likely several as yet unidentified components. The underlying circadian mechanism in bacteria, as worked out in the cyanobacterium *Synechococcus elongatus*, also involves a TTFL, as well as what some have referred to as a post-translational oscillator (PTO) (reviewed by Johnson et al., 2008). It has been proposed that the PTO and TTFL, both of which involve the essential clock genes *kaiA*, *kaiB*, and *kaiC*, form a multi-oscillator system of hierarchically equal, coupled oscillators (Kitayama et al., 2008). The complexity of the circadian system of a simple, single-celled prokaryote once again highlights that such a system must provide a significant advantage to organisms.

2.3 Fine tuning: post-transcriptional and post-translational mechanisms

Post-transcriptional and post-translational modifications of clock genes and proteins are a common feature of all the circadian molecular oscillators studied to date

(Bell-Pedersen et al., 2005; Johnson et al., 2008; Hardin, 2009; Baker et al., 2012; Brown et al., 2012). The circadian molecular machinery is influenced and modulated by a wide range of factors including chaperones, phosphorylation, acetylation, co-activators and co-repressors, and chromatin modifying proteins (Brown et al., 2012). The kinases and other enzymes that perform these reactions have been identified as important clock components, and the modifications themselves serve a variety of roles, including degradation signals, nuclear localization, binding regulators, and signals for recruitment of a variety of additional factors (Mehra et al., 2009; Kojima et al., 2011). It has been suggested that post-translational modifications of clock proteins, especially phosphorylation, regulate the period, phase, and amplitude of the circadian clock (Bae and Edery, 2006; Gallego and Virshup, 2007; Zheng and Segal, 2012). However, the exact means by which the TTFL is maintained and how it generates a roughly 24h period remains unclear, but it is currently believed that it requires delays between various steps of the cycle which are likely provided by various post-transcriptional and post-translational mechanisms (Zheng and Seghal, 2012).

More recently, microRNAs (miRNA) have emerged as key players in the circadian clock (review by Hansen et al., 2011). MiRNAs are small (approximately 22 nucleotides), single-stranded, non-coding RNA species that act as potent gene silencers and are important to a diverse array of physiological and pathophysiological processes. MiRNAs have now been implicated in the circadian regulation of plants (Sire et al., 2009), flies (Kadener et al., 2009), and mammals (Cheng et al., 2007; Gattfied et al., 2009; Na et al., 2009; Alvarez-Saavedra et al., 2011). In mammals, they have been

implicated in the regulation of the central circadian clock in the SCN (Cheng et al., 2007) and peripheral tissue clocks, for example in the liver (Gatfield et al., 2009). In the SCN, miRNAs appear to be able to modulate clock period and entrainment (Cheng et al., 2007) and it has been suggested that in peripheral tissue they may act as post-transcriptional modulators of *Bmal1* (Shende et al., 2011).

2.4 Beyond the molecular oscillator

Despite the success of the transcription-translation feedback model, it is clear that other mechanisms must participate in circadian rhythm generation and maintenance (Hardin 2006, Lakin-Thomas 2006). Prior to the discovery of TTFL-based circadian clockwork, numerous observations of circadian rhythms in the absence of transcription and/or translation were reported from various organisms. For example, in the protozoan *Acetabularia*, circadian rhythms were found to continue in the presence of transcriptional or translational inhibitors (Mergenhagen and Schweiger, 1975b) or even after the removal of the nucleus itself (Mergenhagen and Schweiger, 1975a; Woolum, 1991). Even in model organisms with known TTFL-based clocks, some aspects of circadian physiology are not explained by them. In cyanobacteria clock function persists in cells that divide three or more times in one circadian cycle (Kondo et al., 1997). Remarkably, Nakajima et al. (2005) were able to reconstitute the rhythm of KaiC phosphorylation entirely *in vitro* by combining purified KaiA, KaiB, and KaiC proteins from *Synechococcus*, together with ATP; this *in vitro* rhythm was even temperature compensated! In *Neurospora* circadian spore formation can still be observed under certain conditions in strains lacking the *Frq* locus that is central to the mechanism of the known clock (de Paula et al., 2006;

Dragovic et al., 2002). The mechanism of this Frq-less oscillator remains unknown, though recent evidence suggests that it shares some components with the FRQ/WCC-based clock (Li et al., 2011). In mice it was shown that methamphetamine in the drinking water led to the persistence of rhythmic behaviour in constant conditions even in strains lacking a functional clock due to genetic ablation of clock genes or stereotaxic lesion of the SCN (Honma et al., 1987; Mohawk et al., 2009). Also, mice fed rhythmically show behavioural anticipation of food for some days afterwards, even in SCN-lesioned and some genetically clockless strains (Clarke and Coleman, 1986; Feillet et al., 2006; Pitts et al., 2003). Additionally, mammalian red blood cells, which lack a nucleus, show circadian ATPase activity (Cornelius and Rensing, 1976), acetylcholinesterase activity (Mabood et al., 1978), and hemoglobin oxidation (O'Neill and Reddy, 2011). Based partly on findings such as these some investigators proposed entirely membrane-based clock models (Njus et al., 1974; Edmunds, 1988) and it has more recently been suggested that a complete understanding of the clock must include both genetic (i.e. TTFL) and membrane based (i.e. non-TTFL) feedback loops (Nitabach et al., 2005). Rhythms within the cytosol, for example of second messengers, have recently attracted attention as potential components of the molecular clockwork (Hastings et al., 2008). Circadian rhythms of calcium levels have been reported in a variety of tissues and have been implicated in the regulation of cellular circadian oscillations (Harrisingh et al., 2007) and O'Neill et al. (2008) demonstrated the involvement of cAMP-dependent signalling in the core molecular clockwork. These cytosolic rhythms may function to connect the

circadian molecular oscillator to cell physiology, such as metabolism and axon membrane excitability.

Recent research suggests that the oldest oscillator components may be non-transcriptional in nature and involve peroxiredoxin proteins (O'Neill and Reddy, 2011; O'Neill et al., 2011; Edgar et al., 2012). These proteins are present in virtually all living organisms and were found to undergo daily rhythms of oxidation-reduction across a range of species, including in anucleate mammalian red blood cells (O'Neill and Reddy, 2011; O'Neill et al., 2011; Edgar et al., 2012). Thus, it seems that across many life forms, TTFL and non-TTFL timekeeping processes are not mutually exclusive and rather appear to interact to orchestrate circadian physiology.

3. BODY CLOCKS: DISTRIBUTION OF CLOCKS IN THE ORGANISM

"No clock is more regular than the belly." (François Rabelais)

The CNS integrates information that it receives from the body and coordinates the activity of all bilaterian animals. Therefore, the CNS seemed a likely candidate as the seat of the circadian clock regulating overt rhythmicity. This was shown to be the case in optic lobe clock of insects (Section 3.1.1) and the retinal clock of molluscs (Section 3.1.2). In vertebrates, three central circadian clock centers located in the retina of the eye, the pineal gland, and the suprachiasmatic nuclei (SCN) of the hypothalamus vary in their relationships to each other depending on the taxon (Sections 3.1.3-.3.1.5).

3.1 Clocks in the central nervous system

3.1.1 Insects

The clock network in the brain has been well studied in *Drosophila*. Early studies employed the original clock mutants of Konopka and Benzer (1971). Transplantation of brains from short period mutant flies into arrhythmic flies induced characteristic short period circadian rhythmicity in the hosts, indicating that the brain played an important role in the regulation of these rhythms (Handler and Konopka, 1979). The *period* (*per*) gene was identified and cloned (Bargiello et al., 1984; Reddy et al., 1984) and its expression in a group of neurons called the lateral neurons (LNs) was found to be sufficient for robust circadian locomotor behaviour (Ewer et al., 1992; Frisch et al., 1994) indicating that these neurons are important for circadian rhythms in *Drosophila* behaviour. A large number of LNs project to the accessory medulla (Helfrich-Förster, 2003), an area believed to be closely associated with the circadian clock in insects, as described below for cockroaches and crickets, and a subset of these are immunoreactive to pigment dispersing hormone (PDH) (Helfrich-Förster, 1995).

In cockroaches and crickets the main circadian clock controlling behavioural rhythms is located in the optic lobes (Nishiitsusujii-Uwo and Pittendrigh, 1968; Sokolove and Loher, 1975; Page, 1982; Tomioka and Chiba, 1984; Abe et al., 1997). Transplantation studies suggest that a small area of the cockroach optic lobe near the accessory medulla is the specific location of the clock and that Pigment Dispersing Hormone (PDH) immunoreactive neurons act as clock cells (Homberg et al., 1991; Reischig and Stengl, 2003). PDH has been used to trace the axons of putative clock cells presumably related to those identified in *Drosophila* (Stengl and Homberg, 1994; Abdelsalam et al., 2008); however, no studies have demonstrated cycling of the canonical

clock proteins PER and TIM in these neurons (Homborg et al., 2003; Lupien et al., 2003). In cockroaches and crickets, each single optic lobe is able to drive rhythmicity (Loher, 1972; Sokolove, 1975; Page et al., 1977; Wen and Lee, 2000), indicating that both lobes contain a clock. The two optic lobe clocks of the cockroach interact (Page et al., 1977) and are coupled by several PDH-immunoreactive neurons that connect both accessory medullae (Reischig and Stengl, 2002; Reischig et al., 2004). The two optic lobe clocks of the cricket appear to be only weakly coupled (Wiedenman, 1983; Tomioka et al., 1991; Tomioka, 1993; Ushirogawa et al., 1997). There is evidence of clocks outside the optic lobes in both cockroaches and crickets (Rence and Loher, 1975; Page, 1985; Tomioka, 1985) but no study has revealed their exact location(s).

The genetic and molecular dissection of the circadian clock has contributed to the physiological investigation of the integration of the circadian system. The circadian control of behaviour was investigated in *Drosophila* while the circadian organization of the neuroendocrine system is best understood in the blood-sucking bug *Rhodnius prolixus*. Clock cells in the *Rhodnius* brain have been identified by the presence of cycling PER and TIM and exist in two paired groups, the lateral neurons (LNs) in the optic lobes and the dorsal neurons (DNs) in the posterior protocerebrum (Vafopoulou et al., 2010). The LNs extend axons through the accessory medulla and into the compound eye as well as to the anterior protocerebrum. Two axons from the LNs cross the midline and connect the left and right clock centers. The LNs also project two axons to the DNs, coupling these two groups of clock cells into a 'timing system'. The clock

neuroarchitecture of *Rhodnius* is remarkably similar to that of *Drosophila* despite the evolutionary distance between the species.

3.1.2 Molluscs

A circadian clock is located in the eyes of *Aplysia californica* and *Bulla gouldiana* (Jacklet, 1969; Jacklet and Geronimo, 1971; Eskin, 1979; Block and Wallace, 1982; Jacklet et al., 1996). A circadian rhythm of compound action potentials (CAPs) can be recorded from the optic nerve of an isolated eye of *Bulla* and *Aplysia* that persists in constant environmental conditions (Jacklet, 1969; Block and Wallace, 1982). The site of the *Bulla* circadian clock was localized to a group of 100 or so basal retinal neurons in each eye that are necessary for the CAP rhythm (Block and Wallace, 1982; Block and McMahon, 1984; Block et al., 1984). Even individual, dissociated basal retinal neurons display a circadian rhythm in membrane conductance of K^+ , demonstrating that rhythm generation is a single cell property of the basal retinal neurons of *Bulla* (Michel et al., 1993). The population of basal retinal neurons is coupled by gap junctions into a clock network (Luborsky-Moore and Jacklet, 1977; Jacklet and Colquhoun, 1983; Jacklet, 1988). The bilateral ocular circadian clocks of *Bulla* are also mutually coupled (Roberts and Block, 1983; Block et al., 1986; Page and Navolic, 1992) via the cerebral commissure and the optic nerves (Roberts and Block, 1985). These coupling pathways likely employ glutamate as a neurotransmitter (Michel et al., 2000).

3.1.3 Fish

The zebrafish, *Danio rerio*, has provided insights into the circadian organization of fish (reviewed by Cahill 2002; Vatine et al., 2011). Zebrafish behavioural rhythms are

controlled by a temperature compensated circadian clock (Hurd et al., 1998). The pineal and the retina of the zebrafish are light sensitive, express clock genes rhythmically (Whitmore et al., 1998; Cermakian et al., 2000) and produce melatonin with a circadian rhythm (Cahill, 1996) and therefore represent functional circadian clocks. Recent evidence suggests that the SCN of some teleost fish is also involved in the circadian system (Watanabe et al., 2012). However, the relative contribution of each component, i.e. clock in the retina, the pineal, and the SCN, is unknown. A number of other tissues in the brain and throughout the body of the zebrafish have also been found to possess photosensitive circadian clocks (Whitmore et al., 1998; Cermakian et al., 2000; Kaneko et al., 2006).

3.1.4 Birds

The bird circadian system consists of three mutually coupled circadian clocks in the pineal gland (Takahashi et al., 1980; Robertson and Takahashi, 1988; Brandstätter et al., 2000), the retinas (Binkley et al., 1980; Underwood, 1994), and the hypothalamus (Takahashi and Menaker, 1979, 1982; Brandstätter et al., 2001). The system receives light input from retinal, pineal, and deep encephalic photoreceptors (Cassone and Menaker, 1984; Menaker et al., 1997; Kojima and Fukuda, 1999). The pineal gland contains a circadian oscillator that produces melatonin in a rhythmic fashion (Robertson and Takahashi, 1988; Murakami et al., 1993; Taniguchi et al., 1993) and plays an important role in the avian circadian system. In birds kept in constant darkness removal of the gland abolishes the expression of circadian locomotor rhythms (Gaston and Menaker, 1968), feeding rhythms (Heigl and Gwinner, 1994), and body temperature

rhythms (Binkley et al., 1971). Rhythms can be restored by administration of melatonin (Gwinner and Benzinger, 1978; Chabot and Menaker, 1992; Heigl and Gwinner, 1994). The rhythm is also restored by transplantation of a pineal gland into the pinealectomized host and the restored rhythm has the phase of the rhythm of the donor, indicating that circadian clock properties have been transplanted with the pineal (Zimmerman and Menaker, 1979). The pineal gland and the hypothalamic oscillator are coupled by hormonal and nervous mechanisms. The hypothalamic oscillator possesses melatonin binding sites (Cassone et al., 1995) and therefore receives information from the pineal gland and is connected to the pineal gland by a polysynaptic neural pathway (Ariens Kappers, 1993). A direct retinohypothalamic tract (RHT) connecting the retinas and hypothalamus is present in birds (Cassone and Moore, 1987; Norgen and Silver, 1989; Shimizu et al., 1994) but it remains to be experimentally demonstrated as a relay for circadian input as in the mammalian system (Section 3.1.5). Like the pineal gland, the avian retinas also produce melatonin rhythmically but their role in the circadian system differs between species (Ebihara et al., 1987; Chabot and Menaker, 1992; Heigl and Gwinner, 1994, 1995; Underwood et al., 1990; Underwood, 1994).

3.1.5 Mammals

In mammals the SCN acts as the ‘master’ circadian clock, receiving light input from the eyes via a dedicated RHT and distributing that temporal information to a number of peripheral clocks throughout the organism (Section 3.2). The first indications of the role of the SCN in the circadian system of mammals came from lesioning studies which demonstrated that the SCN affects rhythms of drinking, locomotor activity, and

adrenal corticosterone (Moore and Eichler, 1972; Stephan and Zucker, 1972). The discovery of the first vertebrate clock mutation in the golden hamster (Ralph and Menaker, 1988) led to the demonstration that characteristics of circadian behaviour are determined by the SCN, since transplantation of fetal SCN to SCN-lesioned animals restored circadian wheel running behaviour to the period of the donor (Ralph et al., 1990). Individual SCN neurons express circadian rhythms in spontaneous electrical impulse frequency (Welsh et al., 1995; Liu et al., 1997; Herzog et al., 1998, 2004) but display a large variability in period length (Liu et al., 1997; Herzog et al., 1998, 2004) and cells are independently phased (Welsh et al., 1995). Intercellular coupling is essential to synchronize the SCN neurons (Liu et al., 2007) and multiple mechanisms by which this might be achieved have been proposed, including communication via neuropeptides such as vasoactive intestinal polypeptide (VIP) (Harmar et al., 2002; Colwell et al., 2003; Maywood et al., 2006) and γ -amino butyric acid (GABA) (Honma et al., 2000; Liu and Reppert, 2000; Yamaguchi et al., 2003), and electrical coupling via gap junctions (Colwell, 2000; Albus et al., 2005; Long et al., 2005). GABA appears important in synchronizing the rhythmic output of the SCN neurons (Liu and Reppert, 2000). The two suprachiasmatic nuclei are coupled, most likely by identified bilateral projections between them (Kalsbeek et al., 1993; Leak et al., 1999; Abrahamson and Moore, 2001).

The SCN receive light input from the eyes. Specialized melanopsin-containing retinal ganglion cells communicate with the SCN via the RHT to entrain the circadian clock (Berson et al., 2002; Hattar et al., 2002). These cells are photosensitive, express cycling *per* and *tim*, and produce melatonin rhythmically and therefore contain a bona

vide circadian clock (Ruan et al., 2006, 2008; reviewed by Tosini et al., 2008). The RHT communicates with the SCN via glutamate and pituitary adenylate cyclase-activating poly peptide (PACAP) (Hannibal, 2002). Gastrin releasing peptide and calbindin are involved in relaying light signals to SCN neurons that are not directly retinorecipient (Aida et al., 2002; Hamada et al., 2003). The eyes themselves contain a circadian clock in the retinas that rhythmically synthesize melatonin that acts only locally (Ruan et al., 2006; Tosini and Fukuhara, 2002). The mammalian pineal is not light sensitive (as it is in the non-mammalian vertebrates), but does synthesize melatonin rhythmically (Pévet et al., 2006). This rhythm is driven by the SCN (Moore and Klein, 1974; Klein and Moore, 1979) which is connected to the pineal by a multisynaptic pathway (Perreau-Lenz et al., 2004). The presence of melatonin receptors in the SCN (Vanecek et al., 1987; Stankov et al., 1991; Morgan et al., 1994) implies that the SCN in turn receives information from the pineal in order to maintain synchronization and increase the precision of the system. The pituitary and retina also possess melatonin receptors (Vanecek et al., 1987). The functional connections of retina, SCN, and pineal gland thus provide a neural loop in which melatonin influences the structures that regulate the rhythms of its own synthesis (Reuss, 1996). The SCN can disseminate temporal information to the rest of the organism by neural outputs to peripheral organs (Bartness et al., 2001) and by means of hormones from the hypothalamus and the pituitary (Haus, 2007).

3.2 Clocks in the periphery

Although singled-celled organisms must necessarily contain all the components of a circadian system in one cell, multicellular organisms with differentiated tissues can

partition clock function among different cell types to coordinate tissue specific rhythms and maintain precision (Bell-Pedersen et al., 2005). Many autonomous clocks have been discovered outside the brain in insects and vertebrates (Roenneberg and Merrow, 2001) and circadian clocks seem to be found in almost all metazoan cell types (Schibler and Sassone-Corsi, 2002). The traditional view of circadian systems comprised of a central master oscillator (pacemaker) located in the brain regulating slave oscillators in peripheral organs is no longer applicable. Rather, a more complicated web of independent but communicating clocks throughout the organism organizes the biochemical and physiological events around the 24 hour day. Such a network of coupled oscillators is believed to add to the precision and stability of the clock, while providing the ability of individual oscillators within cells or tissues to control different rhythmic outputs (Bell-Pedersen et al., 2005).

3.2.1 Insects

Insects have played an important role in helping to revise our concept of the organization of circadian systems. A number of potential peripheral oscillators (i.e. clocks outside the CNS) in insects have been analyzed to varying degrees of detail (reviewed in Giebultowicz, 2001; Vafopoulou and Steel, 2009). Two insects in particular have been useful in disentangling the circadian system: *Drosophila melanogaster* has provided us with the molecular and genetic basis of the circadian oscillator and *Rhodnius prolixus* has taught us about clock controlled outputs such as hormones and the coordination of multiple clocks within a multicellular organism (Section 6.2). Since in insects peripheral oscillators can be autonomous and independent of a central clock, I

shall employ the terms central and peripheral oscillators in an anatomical sense as defined by Bell-Pedersen et al. (2005) for *Drosophila*: The ‘central’ oscillator comprises several groups of neurons in the brain that control locomotor rhythms and ‘peripheral’ oscillators comprise all other oscillators in the head and body.

Earlier physiological studies were the first to indicate that peripheral tissues in insects housed autonomous circadian clocks. For example, a possible autonomous circadian clock in the epidermis of the cockroach *Blaberus craniifer* has been suggested based on circadian deposition of endocuticle that persisted in legs cultured *in vitro* (Weber, 1995). Mizoguchi and Ishizaki (1982), using local illumination and transplantation experiments, suggested that the prothoracic glands (PGs) of the moth *Samia cynthia ricini* possess an independent photosensitive circadian clock that controls ecdysteroid rhythms. The existence of a photosensitive PG clock regulating ecdysteroid synthesis was subsequently more firmly established in larval *Rhodnius prolixus* (Vafopoulou and Steel, 1998; see Section 6.2). In the last larval instar of *Galleria melonella* transfer from cool (18°C) to normal (30°C) temperature leads to precision in their development and to pupation in a circadian manner (Cymborowski et al., 1989). These larvae also exhibit circadian rhythmicity in ecdysteroid hemolymph titres with a period close to 24h (Cymborowski et al., 1989). These rhythms appear to persist in prothoracic glands *in vitro* (Cymborowski et al., 1991) and therefore might represent an independent clock similar to *Rhodnius* PGs. In the gypsy moth, *Lymantria dispar*, release of sperm from the testis into the seminal ducts exhibits a circadian rhythm. This rhythm persists *in vitro* in isolated complexes of testis and seminal ducts (Giebultowicz et al.,

1989). The *in vitro* rhythm continues in DD and is reset by shifting the LD cycle. The testes therefore possess a photosensitive circadian clock independent of the brain (Giebultowicz et al., 1989). The rhythm of sperm release may be related to a more recently described rhythm of hemolymph ecdysteroid titre (Polanska et al., 2009).

The molecular tools available have now led to the identification of circadian oscillators in numerous peripheral tissues in *Drosophila*, including the olfactory and gustatory sensilla (Chatterjee et al., 2010; Krishnan et al., 1999; Tanoue et al., 2004), oenocytes (Krupp et al., 2008), prothoracic gland (Myers et al., 2003), epidermis (Ito et al., 2008), fat body (Xu et al., 2008), malpighian tubules (Giebultowicz and Hege, 1997), and male reproductive system (Beaver et al., 2002). The canonical clock gene *per* is expressed in numerous peripheral tissues. Using a *per* β -galactosidase fusion gene, Liu et al. (1988) found *per* to be expressed in *Drosophila* embryonic nervous tissue, pupal prothoracic gland-corpora allata, and optic lobes, and numerous adult tissues including antennae, proboscis, eyes, optic lobes, cells of the central brain, cells of the thoracic ganglia, gut, Malpighian tubules, and ovarian follicle cells. *per* mRNA was also found to cycle in these body tissues with the same phase and amplitude as in the head in LD cycles (Hardin, 1994). One exception is the ovaries in which *per* mRNA did not cycle and remained predominantly cytoplasmic. In constant darkness (DD) the amplitude of *per* mRNA cycling dampened much more quickly in peripheral tissues than in the head, indicating a difference in the behaviour of the circadian oscillators of the head and body (Hardin, 1994). In 1997, Plautz et al. (1997) reported the discovery of independent photoreceptive circadian clocks throughout *Drosophila*. They used the *per*-driven

bioluminescent oscillations in *per-luc Drosophila*, in which *per* is fused to the luciferase gene *luc*, to examine rhythms in *per* expression throughout the fly. In intact animals rhythms in bioluminescence were entrainable to LD cycles and free-ran in DD. In order to examine the circadian autonomy of *Drosophila* tissues, they monitored cultured dissociated body segments (head, thorax or abdomen). They found that each of the three segments bioluminesced rhythmically in LD conditions with the same phase and waveform. Furthermore, rhythmicity was displayed in diverse tissues including: proboscis, antennae, wings, eyes, Malpighian tubules, and testes; ovaries did not display any appreciable cycling. The rhythms persisted in DD and gradually dampened. When returned to LD, re-entrainment occurred within one cycle, demonstrating the capacity for light detection. The authors monitored *per* driven green fluorescent protein (GFP) concurrently and found similar rhythmic expression. GFP was detectable at the near single cell level in chemosensory cells of the legs, wings, antennae, and proboscis. It should be noted that not all tissues in *Drosophila* show detectable levels of either PER or TIM, including epidermis, skeletal muscle, and tracheal epithelium (Giebultowicz, 2001). Although numerous tissues displayed cycling of the clock gene *per* and its products as well as direct photosensitivity and therefore presumably possess an autonomous circadian oscillator, most of these control as yet unknown biochemical and physiological functions.

The antennal chemosensory cell oscillators potentially control rhythmic olfactory responses. Krishnan et al. (1999) reported a robust circadian rhythm in *Drosophila* in electrophysiological responses to two classes of olfactory stimuli. Although it was shown that peripheral oscillators are required to mediate rhythmic olfactory responses in the

antenna (Krishnan et al. 1999), the identity and relative autonomy of these peripheral oscillators was not described. Using targeted ablation of lateral neurons, targeted clock disruption in antennal neurons, and targeted rescue in antennal neuron oscillators, Tanoue et al. (2004) demonstrated that electroantennogram (EAG) rhythms in *Drosophila* antennae are controlled by local oscillators in antennal neurons that function independently of the central brain (lateral neuron) oscillators. With clock function compromised in antennal cells but not in the lateral neurons, EAG rhythms were abolished, implying that the antennal neurons are necessary for rhythmic olfactory responses. When clock function was rescued in antennal cells but not in the rest of the organism rhythmic EAG responses were reinitiated, revealing that a peripheral oscillator can function as a circadian clock to autonomously control a rhythmic physiological output. Additionally, Zhou et al. (2005) demonstrated that a circadian rhythm in olfactory attractive and repulsive responses is driven by non-lateral neuron clocks, probably in the antenna and possibly the same clock cells that control the EAG response described above.

Antennal clocks have been described in other insect species as well. EAG rhythms in the antenna of the cockroach *Leucophaea maderae* were completely abolished by severing the optic tracts and light entrainment was abolished by ablation of the compound eyes (Page and Koelling, 2003), indicating the circadian system modulates olfactory sensitivity in the antennae and that the rhythm is driven by a circadian oscillator in the optic lobes that is entrained by photoreceptors in the compound eyes. This differs from the autonomous photosensitive clocks in the antenna of *Drosophila* described above. Schuckel et al. (2007) reported the existence of (putative) clock cells in the

antennae of the moth *Manduca sexta*. Immunohistochemistry revealed PER-immunoreactive cells in the antennae of *Manduca*. Specifically, immunoreactivity was detected in pheromone-sensitive olfactory receptor neurons, supporting cells, epithelial cells, and antennal nerve glial cells. Expression of *per* mRNA in antenna was confirmed by PCR, but experiments investigating clock protein cycling and demonstrating the circadian nature of expression were not performed. The authors posited that *Manduca* possesses an antennal clock similar to the one in *Drosophila* and that it might be related to rhythms of olfactory pheromone sensitivity (Schuckel et al., 2007). A circadian clock has been reported in the antennae of the moth *Spodoptera littoralis* that may be associated with rhythmic pheromone reception in this species (Merlin et al., 2007). Antennal clocks have now also been identified in monarch butterflies, *Danaus plexippus* in which they were found to coordinate sun-compass orientation during migration (Merlin et al., 2009).

The Malpighian tubules, previously shown to contain cycling *per* mRNA (Hardin, 1994; Plautz et al., 1997), were also found to contain an autonomous circadian clock independent of the brain (Giebultowicz and Hege, 1997; Hege et al., 1997). Rhythms of PER and TIM immunoreactivity in the Malpighian tubules of wildtype flies closely resembled those reported in heads, but were found to persist in decapitated flies and therefore are independent of the brain clock (Giebultowicz and Hege, 1997). Moreover, rhythms of PER and TIM in the Malpighian tubules of decapitated flies persisted in DD and were appropriately reset when subjected to a 12 hour phase shift. Thus, the Malpighian tubules exhibit free-running cycling of clock proteins that can be reset by

light independently of the brain and compound eyes. The use of *per-lacZ* transgenic flies revealed circadian cycling of *per* in the Malpighian tubules, with accumulation in the cytoplasm followed by translocation to the nucleus (Hege et al., 1997). The rhythm persisted in DD and was phase shifted by LD cycles and was almost identical in decapitated flies. This further supports the conclusion that the Malpighian tubules contain a circadian clock that functions independently of the brain. However, the physiological function of this clock has not been described.

Oscillator mechanisms differ between central (brain) and peripheral tissues in insects (certainly in *Drosophila*). For example, rhythms in the central pacemaker (lateral clock neurons) appear more robust whereas those in peripheral tissues dampen rapidly (Hardin, 1994) and while CRY functions in circadian photoreception in the central pacemaker, it plays an additional role in the core molecular oscillator in peripheral tissues (Glossop and Hardin, 2002). In *Drosophila*, cryptochrome (CRY) acts as a photoreceptor that mediates light input into the central circadian clock. Emery et al. (2000) have shown that CRY also mediates photoreception in peripheral oscillators. CRY has been demonstrated to play an additional non-photoreceptor role in the endogenous clock mechanism in some peripheral clocks, including antennae (Krishnan et al., 2001) and Malpighian tubules (Ivanchenko et al., 2001). Moreover, Ivanchenko et al., (2001) showed that CRY is involved in TIM-mediated light entrainment of both central lateral neuron and peripheral Malpighian tubule clocks.

Precisely how much influence the lateral neurons exert over the fly peripheral oscillators is not known, given that light appears to entrain peripheral clocks, thus

negating the requirement for a ‘master’ clock to synchronize other oscillators in the fly (Glossop and Hardin, 2002). It has been suggested that the existence of light sensitive cellular oscillators in many peripheral tissues of *Drosophila* and zebrafish may still be a relic of evolution from single-cell autonomous clocks (Schibler and Sassone-Corsi, 2002). The *Drosophila* circadian system is organized as a distributed set of autonomous clocks, which contrasts with the mammalian and avian circadian systems of a centralized clock that modulates peripheral clocks (Bell-Pederen et al., 2005). An advantage of autonomous light entrainable clocks is that they permit tissue-specific specialization of circadian timing (Bell-Pederen et al., 2005). The concept of multiple oscillators within a single organism is not new and was suggested by Pittendrigh (1960) who proposed that “the organism comprises a population of quasi-autonomous oscillatory systems.” This certainly appears to be true in the case of the circadian organization of the *Rhodnius* neuroendocrine system and probably in *Drosophila* and other insects as well.

3.2.2 Mammals

The conventional viewpoint that the ‘master’ clock in the mammalian SCN drives rhythms in the periphery was overturned by the discovery of circadian expression of clock genes in many peripheral tissues. Circadian clocks have been described and studied in a variety of peripheral tissues and organs including for example the adrenal glands (Dickmeis 2009), the heart (Durgan and Young, 2010), the endocrine pancreas (Marcheva et al., 2010; Sadacca et al., 2011), the liver (Stokkan et al., 2001; Schmutz et al., 2012), and the lungs (Gibbs et al., 2009; Hadden et al., 2012). The use of a luciferase reporter construct driven by the mouse *Per1* clock gene enabled the first demonstration of

cycling clock genes in the periphery (Brandes et al., 1996), but these rhythms dampened rapidly compared to the self-sustained rhythms in the SCN (Yamazaki et al., 2000). By using the mouse *Per2* gene in the reporter construct, Welsh et al. (2004) showed that peripheral rhythms were also self-sustained. Balsalobre et al. (1998) demonstrated that mammalian fibroblasts continue to show circadian cycles of clock genes in long-term culture following a serum shock. In fact, it is now clear that most cell types in mammals, *Drosophila*, and zebrafish seem to contain all the necessary molecular components to achieve circadian gene expression (Balsalobre, 2002). However, in mammals the peripheral clocks ultimately rely on light input from the eyes to be entrained (Balsalobre, 2002). Circadian oscillators in peripheral tissues, in contrast to the central brain clock, appear to remain responsive to phase resetting throughout the day (Balsalobre et al., 2000). This is crucial because the periphery should respond to signals from the SCN at any time. The peripheral oscillators appear to be as robust as the oscillator in the SCN (Nagoshi et al., 2004; Welsh et al., 2004). However, the input to both types of oscillators differs since the major Zeitgeber for the SCN is the environmental light-dark cycle, but for the periphery, Zeitgebers include food uptake, body temperature, and neuronal and humoral signals.

The situation in mammals is now described as a hierarchical organization of cellular oscillators distributed across the organism that are synchronized by SCN-dependent cues, and this synchronization sustains circadian organization at the level of particular organs and also ensures appropriate internal synchronization between different physiological and metabolic systems (Hastings et al., 2007).

3.2.3 Other circa clocks

Other circa rhythms must be regulated by specialized clocks as well. Evidence for an additional autonomous and independent circalunar clock ticking alongside the circadian clock has been reported from a marine annelid, *Platynereis dumerilii* (Zantke et al., 2013). A separate circatidal clock has been proposed for the marine crustacean *Eurydice pulchra* (Zhang et al., 2013). However, the genetic and molecular bases of these rhythms are only beginning to be unraveled (Tessmar-Raible et al., 2011). The results of Kaiser et al. (2011) from the marine midge *Clunio marinus* suggest a close interaction between the circadian and circatidal clocks at the genetic level that may provide a coupling of the two clocks. The first reliable evidence that a lunar rhythm can modulate sleep structure in humans was recently reported by Cajochen et al. (2013). Therefore, multiple clocks regulating different temporal scales and coupled together at a molecular genetic level may turn out to be a widespread phenomenon representing the adaptation of organisms to the various geophysical periodicities to which they are exposed.

4. CIRCADIAN CLOCKS IN PHYSIOLOGY

"Blood reyneth 6h from 9 o'clock in ye night till 3 in the morne, cholic from 3 in the morne till 9: melancholy from 9 till 3 in the even: flegme from 3 till 9 o'clock in the night." (John Wren, Herbal Treatise, 1632)

"Whatever physiological variables we measure, we usually find that there is a maximum value at one time of day and a minimum value at another." (Jürgen Aschoff, 1965)

4.1 Physiological significance of biological clocks

The molecular details of the circadian clockwork are now well understood (see Section 2). However, just as a mechanical clock requires more than gears alone in order to perform its function so the circadian clock requires additional components in order to be biologically useful. An oscillator that is not coupled to environmental cycles and to other processes within the organism cannot act as a meaningful clock since it does not reflect external time and has no hands with which to communicate timing information. A biological clock must therefore be able to synchronize (i.e. entrain) to some environmental cycle either directly or indirectly — i.e. receive inputs — and to direct when various cellular and biochemical events will occur — i.e. produce rhythmic outputs.

The daily cycle of light and darkness is by far the most common entraining signal and in *Drosophila*, for example, the rapid light induced degradation of TIM (Hunter-Ensor et al. 1996) is known to be involved in the light entrainment pathway (see Section 2.1). The primary output of the circadian oscillator is in the form of rhythmic expression of clock controlled genes (CCGs) (Hastings *et al.* 2008), resulting in between 5% and 10% of the transcriptome being under circadian regulation (Ueda *et al.* 2002) and thus leading to the rhythmicity of cellular biochemistry and physiology. In reality circadian organization at all levels of complexity is characterized by several inputs, several oscillators, and many outputs (Roenneberg and Merrow 2005). Both the input pathway(s) to the oscillator and the output pathway(s) leading to the control of the overt rhythms are signal transduction pathways, and are linked by the central oscillator. Thus, the circadian clock is a signaling system that creates temporal order within the organism and links the

environment to physiology (Somers, 1999). Borrowing from Claude Bernard's description of the "milieu extérieur" and the "milieu intérieur," Pittendrigh extended his concept of physiological homeostasis to include a temporal component in his discussion of "the day outside" and "the day inside" (Pittendrigh, 1993).

It is now recognized that nearly every aspect of physiology is influenced by the circadian system. Circadian control of metabolism (Sahar and Sassone-Corsi, 2012; Eckel-Mahan and Sassone-Corsi, 2013; Shi and Zheng, 2013), the immune system (Arjona et al., 2012; Logan and Sarkar, 2012), the endocrine system (Kriegsfeld and Silver, 2006; Haus, 2007; Morris et al., 2012; Tonsfeldt and Chappell, 2012), reproduction (Boden and Kennaway, 2006; Kennaway et al., 2012; Boden et al., 2013), the cell cycle (Hunt and Sassone-Corsi, 2007; Masri et al., 2013), and development (Vallone et al., 2007) has been clearly demonstrated. These findings have produced a clearer understanding of the effects of circadian disruption, as for example produced by shift work, which include increased incidence of diseases such as diabetes, depression, and cancer (Knutson, 2003; Karatsoreos, 2012) and have led to useful practical applications in health and medicine through the development of chronotherapy and chronopharmacology. It is becoming more and more apparent that these various physiological systems are not simply regulated by the circadian system but rather they both receive information from the circadian system and provide information to the clock in order to modulate it according to homeostatic requirements. For example, it has recently been shown that heme, a cofactor in oxidative metabolism, can bind and regulate Rev-Erba activity, thereby linking cellular metabolic cycles into the core clockwork and

connecting the molecular oscillator with metabolic physiology (Yin et al. 2007). Furthermore, *rev-erba* can be regulated by the circadian rhythm of melatonin in the pars tuberalis and is suggested to link the physiological action of melatonin and the core molecular clockwork (Agez et al. 2009). Therefore, the circadian system and physiology are inextricably coupled at a fundamental level.

This is possible because, in metazoans, cells of different types throughout the organism can possess the clock machinery (see Section 2) and be identified as 'clock cells'. It is often the case in complex metazoans that dedicated clock neurons in the central nervous system (CNS) play a unique role as regulators and coordinators of other clocks in the organism (see Section 3). Therefore, the circadian system of complex multicellular organisms is comprised of multiple cellular and tissue clocks that must communicate to produce adaptive temporal organization. It is worth mentioning that even unicellular organisms can possess a multi-oscillator circadian system as demonstrated by the fact that two different rhythms in the dinoflagellate *Gonyaulax (Lingulodinium)* can run independently and that each must therefore be controlled by its own unique oscillator (Roenneberg and Morse, 1993).

The organization of the circadian system has been studied in a variety of animals including molluscs, insects, and vertebrates, and is best understood in insects and mammals (see Section 3). In these large complex multicellular organisms clocks in different tissues must be able to communicate and synchronize with each other. Pittendrigh (1960) proposed that the physiological organization of a population of autonomous oscillators must involve "communication channels whose principal function

is not to impose rhythmicity but merely to couple and hence appropriately phase oscillatory activities inherent in the individual subsystems." Such coupling is required in order to synchronize clocks throughout the organism and is achieved by nervous and hormonal pathways. Hormones are now recognized as playing an especially important role within the circadian system since they can act as both outputs of and inputs to the molecular oscillator and thus participate in the coordination and integration of the system at the level of the whole organism.

4.2 Clocks in the hypothalamo-pituitary-adrenal (HPA) axis

Many hormones show circadian patterns of release and are therefore well placed as signals that might coordinate central and peripheral rhythms (Aschoff, 1979; Hastings et al., 2007; Haus, 2007). Glucocorticoids have been implicated in the regulation of peripheral circadian rhythms and are themselves subject to circadian regulation at many levels of organization (Dickmeis, 2009). Glucocorticoids are secreted with a circadian rhythm that is locked to the activity phase of the animal and are paralleled by similar rhythms in adrenocorticotrophic hormone (ACTH) (Haus, 2007; Dickmeis, 2009). Corticotropin-releasing hormone (CRH) synthesis in the hypothalamus is also under circadian control, however the rhythms of ACTH and CRH appear to only be loosely coupled (Watts et al., 2004).

SCN lesions abolish the rhythms in glucocorticoids and ACTH (Moore and Eichler, 1972; Abe et al., 1979; Szafarczyk et al., 1979; Cascio et al., 1987) and these rhythms are not restored by SCN grafts into SCN-lesioned hamsters, indicating that axonal connections are required for their circadian control (Meyer-Bernstein et al., 1999).

The adrenal glands receive photic cues via axons from the SCN and from ACTH (Moore and Eichler, 1972; Abe et al., 1979; Szafarczyk et al., 1979; Cascio et al., 1987; Meyer-Bernstein et al., 1999). Autonomic connections via the splanchnic nerve transmit light information from the SCN to the adrenals (Buijs et al., 1999; Ueyema et al., 1999), resulting in changes in corticosteroids without accompanying changes in ACTH (Buijs et al., 1999; Ishida et al., 2005) and modulating the adrenal sensitivity to ACTH (Dijkstra et al., 1996; Ulrich-Lai et al., 2006).

In addition to regulation by the SCN via hormonal and nervous pathways, glucocorticoid secretion is also controlled by a peripheral circadian clock in the adrenal glands themselves. Some early work reported the existence of autonomous circadian rhythms in explant cultures of the adrenal gland (Andrews and Folk, 1964; Andrews, 1971) and, more recently, clock genes were found to be expressed rhythmically in the adrenal glands (Bittman et al., 2003; Ishida et al., 2005; Fahrenkrug et al., 2008). The adrenal clock also appears to contribute to gating the sensitivity of the adrenals to ACTH (Oster et al., 2006). Glucocorticoids themselves subsequently contribute to shaping their own circadian rhythm via negative feedback regulation of ACTH in the brain and pituitary (Jacobson, 2005).

Rhythmic secretion of glucocorticoids by the adrenals seems to be a critical mediator of SCN output (Minh et al., 2001) and activation of glucocorticoid receptor signalling can phase shift circadian timekeeping in cells and tissues (Balsalobre et al., 2000). It even appears as though some clock genes in certain brain regions outside the SCN require glucocorticoids for their circadian expression (Amir et al., 2004; Lafont et

al., 2005; Segall et al., 2006). Glucocorticoids have been shown to induce the rhythmic expression of clock genes in peripheral tissues (Yamamoto et al., 2005; Cheon et al., 2013) and therefore likely play an important role as synchronizers of peripheral clocks throughout the organism. Glucocorticoids act on target tissues via mineralocorticoid receptors (MRs) and glucocorticoid receptors (GRs) which are expressed in numerous peripheral tissues and in the brain, though not the SCN (Dickmeis, 2009). GRs are themselves under circadian regulation in peripheral cells and tissues (Herman et al., 1993; Furay et al., 2006; Yang et al., 2006), resulting in the differential circadian receptiveness of these tissues and thus in the gating of certain glucocorticoid responses to particular times of day. Therefore, rhythmic glucocorticoids function to entrain other peripheral clocks and act as messengers of time to cells and tissues that lack clocks of their own.

To summarize, roughly 50 years of research into the adrenal clock has led to the following picture. The adrenals generate a rhythm of corticosteroid release that free runs *in vitro* (Andrews and Folk, 1964; Andrews, 1971). Moreover, they contain cycling clock genes (Bittman et al., 2003; Ishida et al., 2005; Fahrenkrug et al., 2008), indicating that they possess an autonomous circadian clock. The adrenal clock is entrained by the SCN via the splanchnic nerve. The adrenal clock gates the responsiveness of the adrenal glands to ACTH (Dijkstra et al., 1996; Ulrich-Lai et al., 2006) and thereby confines corticosteroid synthesis to certain times of day, thus contributing to the generation of the circadian rhythm described above. Close parallels exist with the circadian system of larval *Rhodnius* discussed below (see Sections 6.2 and 6.3).

4.3 Measuring the days: Photoperiodism

Photoperiodism, the ability of an organism to monitor the changing day length (more likely night length) as an indicator of seasonal variation, may also represent an expression of the circadian clock. The idea that the mechanisms of photoperiodic and circadian timekeeping might be related was first proposed by Bünning (1936). A number of observations have confirmed a connection between the two systems but the precise nature of the relationship remains elusive. Two experimental protocols have proved especially useful in demonstrating a link between photoperiodism and circadian rhythms: experiments employing unnatural light-dark cycles with periods longer than 24h (e.g. Nanda-Hamner and Bünsow protocols) and night interruption experiments, in which a long dark period is systematically interrupted by a short supplementary light pulse that scans the night, have demonstrated the circadian recurrence of photoperiodic induction (reviewed by Tauber and Kyriacou, 2001; Danks, 2005; Saunders, 1997, 2005, 2009). The molecular connection between photoperiodism and circadian rhythms has been sought in elements of the core clockwork such as TIM (Pavelka et al., 2003). In vertebrates, melatonin ‘encodes’ night length and is secreted for a duration that depends on the night length (Goldman, 2001; Hazlerigg and Wagner, 2006). The melatonin signal is presumably ‘decoded’ by target tissues involved in photoperiodic responses (Goldman, 2001; Hazlerigg and Wagner, 2006). The SCN also reads the melatonin signal (Meijer et al., 2007) and therefore the same tissue is involved in both circadian and seasonal time measurement in mammals. The same may be true in insects in which some LNs may be involved in both circadian and photoperiodic phenomena (Shiga and Numata, 2009). In insects ecdysteroids and juvenile hormone (JH) are implicated in the circadian system

and are involved in the regulation of diapause, which is photoperiodically controlled, providing a possible physiological link between these two systems.

5. ENDOCRINOLOGY OF INSECT DEVELOPMENT AND REPRODUCTION

The confluence of the neuroendocrine and circadian systems has been most clearly demonstrated using the larval stage of the insect *Rhodnius prolixus* (review by Steel and Vafopoulou, 2006) and will be further explored in the adult stage in the present work. Therefore, an overview of the endocrine regulation of insect development and reproduction is presented below.

5.1 Historical developments

Hormones were first proposed to be involved in the regulation of insect growth and development by Kopeč (1917, 1922) in the early part of the twentieth century. He showed that the head was required for pupation in the moth *Lymantria dispar* and suggested that it secretes a humoral factor into the hemolymph, a brain moulting hormone. This discovery was largely ignored until Wigglesworth (1934, 1940) confirmed and extended Kopeč's findings using *Rhodnius prolixus*. *Rhodnius*, a blood sucking bug from South America, proved to be ideally suited to these types of studies since a single large blood meal initiates development from one instar to the next eliminating the possibility that Kopeč's results were caused by prevention of continued feeding by headless caterpillars. Wigglesworth (1940) excised the neurosecretory cells originally identified by Hanström (1938) in the *Rhodnius* brain and demonstrated that this had the same effect as removing the entire brain. These cells were therefore concluded to be

responsible for the ‘brain hormone’ controlling moulting and this was one of the first demonstrations of a hormonal function for nerve cells.

Both Kopeč (1922) and Wigglesworth (1934) noted that the brain was required for a certain number of days during development, but that after this ‘head critical period’ normal development would proceed without it. It was therefore assumed that the head critical period represents a time when development switches from brain hormone dependence to brain hormone independence and that the brain hormone ceases to be produced at that time. More recently, techniques developed to measure titres of the brain hormone have revealed that it continues to be produced and released throughout larval-adult development in *Rhodnius* (Vafopoulou et al., 1996a). Therefore, the exact nature of the head critical period remains obscure.

A second hormone was proposed to be involved in the control of moulting in some insects. Hachlow (1931) and Bodenstein (1948) discovered that after sectioning pupae of a variety of Lepidoptera only those sections that included the thorax continued to develop. Fukuda (1940) used transplantation experiments to show that the immediate source of this thoracic ‘moulting hormone’ was in fact a pair of glands in the thorax which he termed the ‘prothoracic glands’ (PGs). The relation between the brain hormone and the moulting hormone was unclear. Plagge (1938) had noted that implanting a brain into brainless larvae induced pupation, but not of the posterior segments of ligated larvae. Plagge’s results lead Piepho (1942) to suggest that the brain hormone serves to induce the PGs to secrete the moulting hormone. This scheme was experimentally verified by Williams (1947) using diapausing pupae of the giant silkworm *Hyalophora cecropia*. He

found that a photoperiodically induced brain implanted into the isolated abdomen of a diapausing pupa only renews development if the PGs are implanted as well. These results were subsequently confirmed for non-diapausing insects in the cockroach *Periplaneta* (Bodenstein, 1953), the blow fly *Calliphora* (Possompès 1953), and the bug *Rhodnius* (Wigglesworth, 1952). The brain hormone is now referred to as prothoracicotropic hormone (PTTH) because of its action on the PGs.

The insect will emerge after ecdysis as either another larval instar or will have developed into the adult. The larval or adult character of the moult was found to be affected by some factor from the head of *Rhodnius prolixus* that would inhibit metamorphosis to the adult (Wigglesworth, 1934). By cutting through the head at different levels, Wigglesworth determined that the corpus allatum (CA) was the source of this factor, which he termed ‘inhibitory hormone.’ Removal of the CA from first instar larvae led to the development of adult characters and implantation of the CA from a fourth instar into a fifth instar produced giant sixth and even seventh instar supernumary moults rather than an adult. Similar effects of an ‘inhibitory hormone’ were demonstrated in a variety of insects including the silkworm *Bombyx* (Bounhiol, 1938), the stick insect *Carausius* (Pflugfelder, 1937), the beetle *Tenebrio* (Radtke, 1942), and the grasshopper *Melanoplus* (Pfeiffer, 1945). By implanting several corpora allata from larval insects into an adult, the adults could be induced to produce a new cuticle underneath the adult cuticle and this new cuticle showed partial recovery of larval characters (Wigglesworth, 1939, 1940). This ‘reversal of metamorphosis’ demonstrates that the CA not only inhibits development of adult features but actually exerts a positive influence on the expression of

larval characters. The name was therefore changed from ‘inhibitory hormone’ to juvenile hormone (JH).

With the addition of JH to the ecdysteroids and PTTH, the triumvirate of classical insect developmental hormones is complete. By the early 1950’s it was understood that PTTH from the brain stimulates the PGs to produce ecdysteroids which engender a moult cycle. Ecdysteroids produced in the presence of JH leads to a larval moult, whereas ecdysteroids in the absence of JH leads to metamorphosis to the adult. This is referred to as the classical scheme of insect endocrinology. The relationships between PTTH and ecdysteroids have been substantially revised since 1996 by the introduction of circadian regulatory concepts, primarily by the work of Steel and colleagues (Steel and Vafopoulou, 2006).

5.2 Prothoracicotropic hormone (PTTH)

The chemical nature of the ‘brain hormone’, PTTH, was first studied using a bioassay involving the inactive PGs of a brainless Lepidopteran pupa. In a series of studies, Kobayashi and colleagues found that a variety of lipid extracts and even cholesterol alone would activate the PGs and cause renewed growth (Kobayashi and Kirimura, 1958; Kirimura et al., 1962; Kobayashi and Yamasaki, 1966). The protein nature of the brain hormone was identified by Ichikawa and Ishizaki (1963) who subsequently obtained a highly active mixture of peptides from the brain of *Bombyx mori* (Ishizaki and Ichikawa, 1967). *Bombyx* PTTH was finally purified from the heads of 1.8 million adult *Bombyx* (from 1.5 tons of moths) and its amino acid sequence determined by Kataoka et al. (1987, 1991). The PGs, the only known target of PTTH, degenerate and

disappear soon after or shortly before the moult to the adult stage, except in the Thysanoptera which continue to moult as adults (Gabe, 1953). The fact that such high quantities of PTTH, a 'larval' hormone, were found in adult insects remains unexplained.

Analysis soon revealed that PTTH is a member of the growth factor superfamily of peptides (Noguti et al., 1995). To date, the PTTH of eight other insects has been characterized and cloned (Rybczynski, 2009) but *Bombyx* PTTH remains the only PTTH to have been purified. It has sometimes been claimed that PTTHs are species specific (Agui et al., 1983; Ishizaki et al., 1983). However, using a sensitive *in vitro* PTTH assay, Vafopoulou and Steel (1997) demonstrated that *Bombyx* PTTH can successfully stimulate the PGs of the unrelated *Rhodnius prolixus* at a similar dose needed to stimulate *Bombyx* PGs, thus seriously discrediting the claim of functional species specificity.

The source of PTTH in the brain was found to be two pairs of neurosecretory cells which were first localized in *Manduca* by Agui et al. (1979). Similar PTTH cells were subsequently identified in other insects, including *Drosophila* (Žitňan et al., 1993) and *Rhodnius* (Vafopoulou et al., 2007). Sauman and Reppert (1996) demonstrated the co-localization of PTTH mRNA and protein to the same cells in the *Antheraea* brain, implying that these are in fact the cells that produce the hormone. The identification of the PTTH neurosecretory cells allowed Agui et al. (1979, 1980) and Carrow et al. (1981) to determine that the corpora allata, not the corpora cardiaca, served as the main release site for the hormone. This was subsequently supported by immunohistochemical studies (Mizoguchi et al., 1990; Dai et al., 1994).

Once released, PTTH travels in the hemolymph to target (e.g. PG) cells. PTTH has recently been shown to act via the receptor tyrosine kinase Torso in *Drosophila* (Rewitz et al., 2009) and *Bombyx mori* (Young et al., 2012). The mode of action of PTTH on PG cells is summarized by Gilbert et al. (2002) and Rybczynski (2009). PTTH induces an increase in the cytoplasmic calcium ion concentration of PG cells which leads to the activation of a calcium/calmodulin-dependent adenylate cyclase that converts adenosine triphosphate (ATP) to the second messenger cyclic adenosine monophosphate (cAMP). cAMP then modulates the activity of a variety of protein kinases, ultimately leading to the increased transcription and translation of enzymes involved in the ecdysteroidogenic pathway. Eventually, protein phosphatases are activated leading to the termination of ecdysteroidogenesis.

Despite the original purification of PTTH from the head of adult moths (Kataoka et al., 1987, 1991), PTTH has generally been considered a strictly larval hormone and its potential role(s) in adults has been neglected. PTTH immunoreactive neurons have been identified in the brain of adult *Manduca sexta* (Westbrook et al., 1993) and *Rhodnius prolixus* (Vafopoulou et al., 2007). PTTH mRNA expression has been reported in several neurons in the brain of *Drosophila* (McBrayer et al., 2007) and from the head of the mosquito *Culex pipiens* (Zhang and Denlinger, 2011), though the presence of the PTTH peptide was not investigated in either species. Expression of the PTTH receptor torso was reported in adult *Drosophila* ovaries (Rewitz et al., 2009) and more recently in adult *Drosophila* male accessory glands (Heintze et al., 2013). Collectively, these results suggest that PTTH continues to be expressed and possibly functional in adult insects,

though the stimulation of ecdysteroidogenesis by larval PGs remains its only known function (Rybczynski et al., 2009).

5.3 Ecdysteroids

The stimulation of the PGs by PTTH leads to the production and release of the moulting hormones, ecdysteroids. Ecdysteroids represent a family of some 300 sterol derivatives, of which about 70 have been described in insects (Lafont et al., 2005). The steroid structure of the moulting hormone was revealed well before the identity of PTTH was elucidated. Butenandt and Karlson (1954) purified ecdysone from 500 kg of *Bombyx mori* pupae. The full structure of ecdysone (α -ecdysone, E), a highly hydroxylated steroid hormone, was described by Huber and Hoppe (1965). A second, more polar substance with higher activity, was soon described that possessed a sixth hydroxyl group and became known as β -ecdysone or 20-hydroxyecdysone (20E). In most insects, the PG produce ecdysone (or another ecdysteroid) as a precursor to be converted to the biologically active 20-hydroxyecdysone by a P450 hydroxylase (ecdysteroid monooxygenase) in peripheral tissues (reviewed in Gilbert et al., 2002; Spindler et al., 2009).

Once inside a target cell, 20E can bind to its receptor and initiate the transcription of ecdysone regulated genes. The nuclear ecdysteroid receptor acts as a ligand-dependent transcription factor and is a heterodimer composed of the ecdysone receptor (EcR) and Ultraspiracle (USP), an ortholog of the retinoid X receptor (RXR) (Henrich, 2009). The active moulting hormone, 20E, stabilizes the EcR heterodimer so that it can bind to DNA at an EcR response element (EcREs) and regulate transcription of specific genes.

Ecdysteroids can also elicit rapid non-genomic effects but the mechanism by which this occurs is not well understood (Schlattner et al., 2006).

Compared to other animal steroid hormones the ecdysteroids are fairly polar, making them water soluble while still being able to penetrate the more lipophilic cell membranes. These properties allow the ecdysteroids to circulate through the hemolymph and distribute to target cells fairly easily. The development of a radioimmunoassay for ecdysteroids in the seventies (Borst and O'Connor, 1972) greatly improved the ability to produce precise and consistent measurements of hemolymph titres. Ecdysteroid titre profiles during the course of growth and development were produced for many insects (Steel and Vafopoulou, 1989). One common theme is the dramatic rise and fall of ecdysteroid concentration during each developmental stage (Steel and Vafopoulou, 1989). In holometabolous insects, a smaller peak at the beginning of the last larval instar switches the developmental commitment of the epidermis from larval to pupal (Riddiford, 1978). Sláma (1980) found that ecdysis could be delayed by injecting 20E toward the end of a stage, demonstrating that low levels of ecdysteroids are essential for ecdysis. The changing ecdysteroid titre has been found to have important physiological effects by mediating gene transcription in target cells and ultimately orchestrating the sequence of events involved in moulting and metamorphosis (Truman, 2005; Žitňan et al., 2007; Spindler et al., 2009).

Several other peptides, besides PTTH, have been identified as having an effect on ecdysteroidogenesis by the PGs. The first insulin-like peptide (ILP), bombyxin, was originally identified as a molecule with PTTH-like activity (Nagasawa et al., 1984) and

has been shown to stimulate ecdysteroidogenesis by *Rhodnius* PGs *in vitro* (Vafopoulou and Steel, 1997). It has been suggested that in the *Rhodnius* PGs the ILP and PTTH signaling pathways may interact (Vafopoulou and Steel, 2014). Both myoinhibitory peptide/prothoracicostatic peptide (Hua et al., 1999) and *Bombyx* myosuppressin, an FLRFamide peptide (Yamanaka et al., 2005) seem to inhibit ecdysteroid production. The role of these inhibitory peptides in the control of steroidogenesis by the PGs is not well understood. Yamanaka et al. (2006) also identified some FMRFamide-related peptides with inhibitory effects that are apparently delivered to the PGs by direct innervations from the first thoracic ganglion. Generalization is made difficult by the fact that innervation of the PGs is not universal in insects (Sedlak, 1985). Recently a stimulatory autocrine factor has been reported to act in both holometabolous (*Bombyx mori*; Gu, 2007) and hemimetabolous (*Locusta migratoria* and *Schistocerca gregaria*; Vandermissen et al., 2007) insects.

Ecdysteroids have also been shown to play a role in the regulation of reproductive processes. In a number of Diptera, ecdysteroids replace JH as the major gonadotropic hormone stimulating vitellogenin (VG) synthesis and uptake (Raikhel et al., 2005). Bellés and Maestro (2005) suggest that in less specialized insects (e.g. Dictyoptera) vitellogenesis, the uptake of vitellogenin by the developing oocyte, is mainly under the control of JH, with ecdysteroids only involved in activation of choriogenesis, the formation of the chorion around the developing oocyte, while in more specialized groups (e.g. Diptera) vitellogenesis is primarily regulated by ecdysteroids produced by the ovaries, with JH acting on several tissues, including fat body and ovaries, enabling them

to perform their adult-specific functions. Three functions of ovarian ecdysteroids have been described in different species: stimulation of meiotic reinitiation, secretion into the hemolymph for promotion of developmental events in other tissues, and conversion of ovarian ecdysteroids to various conjugates for transfer to the developing oocytes (Brown et al., 2009). Some ovarian ecdysteroid conjugates may also represent inactivation waste products (Brown et al., 2009). The ovarian follicular epithelium has been shown to be responsible for ecdysteroid production in several insects (Hagedorn, 1985).

Some ecdysteroids produced by the ovaries are known to be stored as conjugates in the developing eggs (Hagedorn, 1985). In many species, ecdysteroids are synthesized by the ovaries, accumulated in the mature ovaries, and transferred to the eggs. The ecdysteroids in eggs are mostly ecdysteroid-phosphate conjugates that are considered to be physiologically inactive storage forms that are used as the source of free hormones during embryonic development (Sonobe and Yamada, 2004). The developing embryo then deconjugates and uses these ecdysteroids to regulate embryonic moults prior to the differentiation of active PGs. Ecdysteroids, including ecdysone, 20E, 26-hydroxyecdysone and makisterone A, have been demonstrated in the eggs of a variety of insects, including *Bombyx mori*, *Manduca sexta*, *Oncopeltus fasciatus*, *Aedes aegypti*, *Locusta migratoria*, and *Schistocerca gregoria* (Sonobe and Yamada, 2004).

In some Diptera, ovarian ecdysteroidogenesis is known to be initiated by neurohormones. Egg development neurosecretory hormone (EDNH) was described in mosquitoes (Lea, 1972) and later isolated, characterized, and renamed ovary ecdysteroidogenic hormone (OEH) because of its direct stimulation of ovarian

ecdysteroidogenesis (Brown et al., 1998). OEH may activate ovarian ecdysteroidogenesis through an insulin signalling pathway (Raikhel et al., 2005). Locust neuroparsins are closely related to OEH and produce anti-JH effects (e.g. inhibit oocyte growth) on the locust ovary, but ecdysteroids have no known role in adult locusts (Girardie et al., 1987; Badisco et al., 2011). Neuropeptide F (NPF), the invertebrate counterpart to neuropeptide Y, may also be involved in the regulation of reproduction in locusts as it was shown to stimulate vitellogenesis and oocyte growth (Schoofs et al., 2001) and to increase ecdysteroid levels in the hemolymph and ovaries (Van Wielendaele et al., 2013). ILPs, including bombyxin, are known from a variety of insect species and have been implicated in the control of oogenesis, vitellogenesis, and ovarian ecdysteroidogenesis (Raikhel et al., 2005; Manière et al., 2009). Allatostatins and allatotropins play a role in insect reproduction by regulating JH, but allatostatins might also inhibit ecdysteroidogenesis by ovaries (Brown et al., 2009). Another peptide involved in vitellogenesis and oocyte growth in female locusts is the ovary maturing parsin (OMP), but it is only known from some Orthoptera (Raikhel et al., 2005). A factor from the ovaries was found to inhibit egg development in mosquitoes and was named trypsin-modulating oostatic factor (TMOF) (Bellés and Maestro, 2005).

Ecdysteroids have also been shown to affect spermatogenesis, specifically they have been demonstrated to stimulate the early steps of spermatogenesis in many insects (Hagedorn, 1985; Raikhel et al., 2005). In *Rhodnius*, for example, 20E has been shown to increase the rate of mitosis in the spermatogonial cells that begins during the last larval instar (Dumser, 1980). The testes of some insects, mostly Lepidoptera, have been shown

to produce ecdysteroids and this ecdysteroidogenic activity can be induced by a brain peptide, termed testis ecdysiotropin (TE) (Loeb et al., 2001). *Lymantria* TE successfully stimulated ecdysteroid production by the testes, but not the PGs, of *Rhodnius prolixus* (Vafopoulou and Steel, 2005). A daily rhythm of hemolymph ecdysteroid titre was reported in the moth *Spodoptera littoralis* (Polanska et al., 2009) that corresponded with the rhythmic release of sperm from the testes. However, the origin of the ecdysteroids in the hemolymph was not clear. Ecdysteroids also function in the regulation of male accessory gland function (Raihkel et al., 2005).

5.4 Juvenile hormone (JH)

Active JH extracts were first obtained from *Hyalophora cecropia* by Williams (1956). Material with JH activity from the beetle *Tenebrio* was shown to be a mixture of the terpene alcohol farnesol and its aldehyde farnesal (Schmialek, 1961), which led Bowers et al. (1965) to prepare the methyl ester of farnesenic acid with an epoxy ring in the C10-11 position. The compound obtained by Bowers et al. (1965) showed a much wider range of JH activity. Röller extracted a similar compound from *Hyalophora* which became known as JH I (Röller and Bjerke, 1965; Röller and Dahm, 1968). Another similar compound was isolated by Meyers et al. (1968) and was named JH II, while the original compound synthesized by Bowers et al. (1965) is now known as JH III. JHs have now been identified from over 100 insects representing at least 10 orders, with JH III being the most common (Gilbert et al., 2000). In some cases, e.g. the Lepidoptera, multiple JH homologues are found in the same insect (Gilbert et al., 2000). A variety of

related compounds with JH activity has been isolated from insects and numerous JH analogues have been synthesized as potential insect control agents.

Although the JHs are water soluble at physiological levels, their amphiphilic nature results in non-specific binding to almost any surface (Goodman and Granger, 2009). JH in the hemolymph will therefore bind to a variety of molecules non-specifically, but this might be biologically irrelevant (Goodman and Granger, 2009). The high-affinity juvenile hormone binding proteins (JHBP) likely play an important role in the control of JH titre by regulating the amount of active hormone that is transported (Gilbert et al., 2000). JHBP also protect JH from degradation by non-specific hydrolytic enzymes but not against JH esterase (Gilbert et al., 2000; Goodman and Granger, 2009). The mechanism by which JHBP transports JH from the hemolymph to the cellular JH receptor is not well understood (Gilbert et al., 2000).

JH action has now been established to be mediated by the specific intracellular receptor Methoprene Tolerant (Met) (Riddiford, 2012; Jindra et al., 2013) in holometabolous insects such as *Tribolium castaneum* (Konopova and Jindra, 2007) and *Drosophila* (Abdou et al., 2011; Charles et al., 2011) and the hemimetabolous bug *Pyrrhochoris apterus* (Konopova et al., 2011). A Met ortholog was identified in the ametabolous firebrat *Thermobia domestica* (Charles et al., 2011), supporting the view that the reproductive function of JH predates its role in larval moulting and metamorphosis (Sehnal et al., 1996). Met, like JH, is found only in insects and is the only member of the bHLH-PAS protein family known to act as a hormone receptor (Jindra et al., 2013). JH often modulates the effects of ecdysteroids during moulting and

metamorphosis (Riddiford, 1994; Riddiford, 2012) and this may be the result of the known interaction of Met with EcR and USP, the subunits that form the heterodimeric ecdysteroid receptor (Li et al., 2007; Bitra and Palli, 2009).

Synthesis of JH by the CA is said to be controlled by inhibitory (allatostatins) and stimulatory (allatotropins) peptides produced by neurosecretory cells in the brain and transported axonally to the corpora allata where they exert their effect (Weaver and Audsley, 2009). There are at least three types of allatostatins and two types of allatotropins which occur in a wide variety of insects (Weaver and Audsley, 2009). The CA are also innervated by non-neurosecretory neurons and therefore might also be under nervous control. The neurotransmitters octopamine and dopamine have been shown to affect JH synthesis, although the main functions of these molecules may be unrelated to JH (Gilbert et al., 2000). The nuclei of *Manduca* CA cells contain ecdysteroid receptors (Bidmon et al., 1992) and may control the switch in responsiveness to dopamine (from stimulatory to inhibitory) during larval-pupal development (Granger et al., 1996).

Besides its so called 'status quo' action in moulting and metamorphosis, juvenile hormone participates in the control of insect reproduction. The involvement of the CA in reproduction was originally proposed by Wigglesworth (1936) based on studies with *Rhodnius prolixus*. He showed that removal of the head including the CA interfered with normal oocyte development, but that removal of the brain while leaving the CA intact allowed complete maturation of the eggs. Parabiosis experiments indicated that a circulating hormone was responsible (Wigglesworth, 1936). He also showed that the hormone was not species specific since the corpus allatum of *Triatoma* induced

development of *Rhodnius* eggs (Wigglesworth, 1936). Wigglesworth (1948) demonstrated that the CA of larval *Rhodnius* would induce yolk formation and that farnesol, a JH analog, had both a JH effect and a yolk-promoting effect in *Rhodnius* (Wigglesworth, 1961).

JH appears to be the main regulator of female reproduction, its major role being the control of VG synthesis by the fat body and VG uptake by the ovarian follicle cells (Raihkel et al., 2005). In most insects, JH stimulates the fat body to produce VG and promotes its uptake by the developing eggs in the ovary (Raihkel et al., 2005). ILPs have recently been shown to participate in the JH-mediated induction of VG synthesis by the fat body in the red flower beetle *Tribolium castaneum* (Sheng et al., 2011). JH controls the patency of the follicular epithelium during vitellogenesis, as demonstrated most notably by Davey and colleagues in *Rhodnius prolixus* (Wyatt and Davey, 1996). In many insects, JH also affects various aspects of ovarian development, including oocyte development and differentiation of the follicular epithelium (Raihkel et al., 2005).

In male *Rhodnius* Wigglesworth (1936) found that the corpus allatum affected the accessory glands responsible for producing the spermatophore (Wigglesworth, 1936). The role of JH in spermatogenesis is less clear. JH has been shown to antagonize the stimulatory effects of ecdysteroids during early spermatogenesis and to have stimulatory effects during late spermatogenesis (Wyatt and Davey, 1996).

6. CIRCADIAN PHYSIOLOGY OF LARVAL RHODNIUS

"The thread that will best bind together and give meaning to all the wonders of insect life is physiology." (Vincent Wigglesworth, 1966)

6.1 *Rhodnius*, a model organism in circadian physiology

Rhodnius prolixus Stål is a blood sucking bug (Hemiptera: Reduviidae) from South America and is a vector of the Chagas' disease-causing parasite *Trypanosoma cruzii*. *Rhodnius* proceeds through five larval instars before undergoing 'incomplete' metamorphosis to the mature reproductive adult stage. *Rhodnius* is an obligate blood feeder and requires a single large blood meal to initiate development from one larval stage to the next and to trigger a reproductive cycle in adults (Uribe, 1926; Buxton, 1930). Wigglesworth immediately recognized the tractable nature of *Rhodnius* biology and pioneered its use in his landmark studies in insect physiology. *Rhodnius* has since become a classic model in the field and a vast literature on its endocrinology and physiology continues to grow today. *Rhodnius* is ideally suited to studies of circadian physiology primarily due to the ability to synchronize development of an experimental population with a single blood meal. The precise developmental synchrony that is achieved is a reflection of the meticulous orchestration of the underlying physiological mechanisms (i.e. endocrine control). Collection of tissue samples is facilitated by the relatively large size of the insect (adult *Rhodnius* is roughly 2.5-3 cm long). Additionally, the *Rhodnius prolixus* genome shotgun database is now available and complete annotation is underway, encouraging the use of molecular techniques.

6.2 Circadian orchestration of larval development of *Rhodnius prolixus*

Studies of *Rhodnius* larval-adult development have provided the first insights into the circadian organization of the neuroendocrine system in any insect (reviewed by Steel and Vafopoulou, 2006; Vafopoulou and Steel, 2009). The elucidation of the larval

circadian system (Fig. 2) was initiated by the observation of a circadian rhythm of gated ecdysis in a population of *Rhodnius* (Ampleford and Steel, 1982). Ecdysis is controlled by ecdysteroids (Raikhel et al., 2005) and, in *Rhodnius*, the hemolymph ecdysteroid titre changes dramatically during the roughly 21 days of larval-adult development (Steel et al., 1982). Massive fluctuations of ecdysteroid levels in the hemolymph were found to occur within each day and to be under circadian control (Ampleford and Steel, 1985), and are therefore likely involved in the circadian regulation of ecdysis. The prothoracic glands (PGs), the site of ecdysteroid synthesis in larval insects, were found to contain autonomous photosensitive circadian oscillators that regulate rhythmic ecdysteroidogenesis during larval-adult development (Vafopoulou and Steel, 1989, 1991, 1992, 1998). Every cell of the PGs is reportedly immunoreactive to PER and TIM (Terry and Steel, 2001), demonstrating that the PG cells possess the circadian molecular machinery.

Ecdysteroidogenesis by the PGs is known to be regulated by the cerebral neuropeptide PTTH (Gilbert et al., 2002). The development of an *in vitro* bioassay relying on the stimulatory effect of PTTH on larval PGs provided the most accurate determinations of the timing of PTTH release during larval-adult development (Vafopoulou and Steel, 1993). Three distinct release times were observed: 1) immediately following the blood meal, 2) around day 6 after the blood meal at the so called 'head critical period' (HCP), and 3) sporadic release from days 6-12. All three release times correspond with the observed changes in ecdysteroid synthesis and titres during development. The third period of PTTH release had not previously been reported

Figure 2: The circadian timing system regulating development in larval *Rhodnius* (from Steel and Vafopoulou, 2006). CA, corpus allatum; CC, corpus cardiacum; MNC, medial neurosecretory cell.

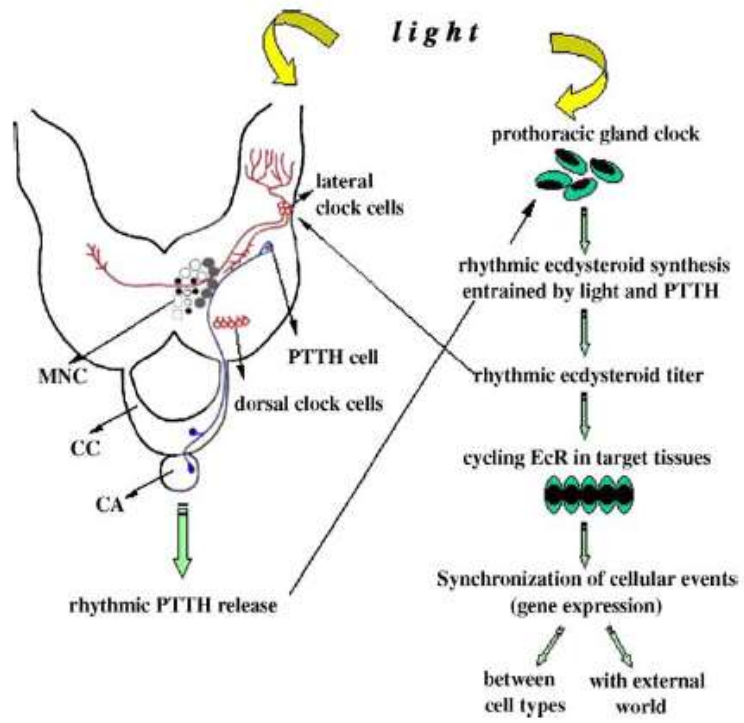

in any insect and it was suggested that it might play a role in the circadian regulation of ecdysteroid synthesis, despite not being qualitatively necessary for the continuation of development (Vafopoulou and Steel, 1993).

A refined version of the *in vitro* assay mentioned above revealed that PTTH release is rhythmic and under circadian control (Vafopoulou and Steel, 1996a, b). PTTH release peaked during the scotophase, corresponding to the scotophase peaks of ecdysteroid synthesis and suggesting that these two circadian rhythms are coupled *in vivo* forming a multi-oscillator system that imposes temporal order during larval-adult development (Vafopoulou and Steel, 1996a). In animals in which PTTH release was prevented by either decapitation or injection of a sub-lethal dose of tetrodotoxin (TTX) that engendered flaccid paralysis the hemolymph ecdysteroid titre rhythm showed a reversal of phase (shifted roughly 12h) from that of intact animals (Pelc and Steel, 1997). These results suggest that PTTH might function as an entraining agent to the PGs, serving to synchronize the phase of these two otherwise independent rhythms. Therefore, the PG clocks appear to respond to both light and PTTH as Zeitgebers, with PTTH as the dominant signal *in vivo*.

Responsiveness of PGs to PTTH also changes with a daily rhythm with high responsiveness around dusk and almost complete lack of responsiveness during the daytime (Vafopoulou and Steel, 1999). This rhythm in responsiveness phase leads the rhythms described for PTTH release and ecdysteroid synthesis by several hours and may represent a daily rhythm of up- and down-regulation of availability of the PTTH receptor. Cyclic adenosine monophosphate (cAMP) acts as a second messenger during PTTH-

stimulated ecdysteroid synthesis by the PGs (Smith et al., 1984, 1985, 1986; reviewed by Rybczynski, 2009) and might therefore represent an important link with the core molecular clockwork (O'Neill et al., 2008).

Calcium (Ca^{2+}) also plays a role as a second messenger during PTTH signal transduction in the PGs and is required for PTTH-stimulated ecdysteroid synthesis by the PGs (Smith et al., 1985). Ca^{2+} -dependent action potentials have been reported in the PGs (Eusebio and Moody, 1986). Considering the probable involvement of Ca^{2+} in the core molecular clockwork (Harrisingh et al., 2007; See Section 2.4), it is possible that Ca^{2+} plays a role in the PG clock. Transfer of arrhythmic animals in which PTTH is reduced to undetectable levels to dark was found to initiate rhythmic PTTH release (Vafopoulou and Steel, 2001), indicating that the clock regulating PTTH release responds to a 'lights off' signal. A 'lights off' cue was similarly shown to reinitiate rhythmic ecdysteroid synthesis *in vitro* (Vafopoulou and Steel, 1998) and *in vivo* (Vafopoulou and Steel, 2001).

Ecdysteroids are critical developmental hormones in insects that mediate changes in nearly all cell and tissue types (Riddiford, 1985) and are therefore ideal universal messengers. Ecdysteroids exert their effects on target tissues via the ecdysteroid receptor EcR. Tissues of unfed insects, that contain no ecdysteroids, were found to be absent of EcR (Vafopoulou et al., 2005). EcR expression was induced in numerous tissues by a blood meal, though the PGs appear to be unresponsive to ecdysteroids as they do not express EcR (Vafopoulou and Steel, 2005). Different tissues express EcR at different times during development and therefore in the presence of very different concentrations of ecdysteroids (Vafopoulou and Steel, 2005, 2012c). Nuclear abundance of EcR also

cycles with a daily rhythm that is under circadian control in some tissues but not others (Vafopoulou and Steel, 2006), implying that these tissues detect and respond to the temporal information inherent in ecdysteroid signal (Vafopoulou and Steel, 2006). Ecdysteroids therefore appear to be important messengers of time to cells lacking clocks, synchronizing them with each other and with the external world. The lateral clock neurons in the brain demonstrate rhythmic EcR cycling, suggesting that the circadian timing system in the brain is sensitive to rhythmic ecdysteroid signals (Vafopoulou and Steel, 2006) and possibly strengthening the coupling between PG and brain clocks.

The PTTH-ecdysteroid axis regulating development in *Rhodnius* contains at least four circadian oscillators: two in the brain and one in each PG. This neuroendocrine axis therefore contains multiple coupled oscillators which collectively comprise the timekeeping system (Vafopoulou and Steel, 2001). Collectively, these results lead to the following scenario. Photosensitive lateral clock neurons organized into two loci in the brain control rhythms of PTTH release. Ecdysteroid synthesis and release are controlled by autonomous photosensitive peripheral clocks, one in each PG. Rhythmic stimulation of the PGs by PTTH serves to adjust the phase of the PGs thereby acting as a hormonal zeitgeber. Cycling EcR within the lateral clock neurons provides temporal feedback from the PGs to the clock cells and thence to the PTTH cells. Therefore, rather than a hierarchical organization of pacemaker and slave oscillators, the neuroendocrine system of *Rhodnius* is organized into a circuit of independent but communicating clocks that together regulate circadian rhythms controlling development. Whether this is common among insects is impossible to determine at present due to the fragmentary state of

knowledge of the circadian organization of the neuroendocrine system in other insects. Independent circadian clocks have been reported in the PG portion of the *Drosophila* ring gland (Emery et al., 1997) and in the moths *Samia cynthia ricini* (Mizoguchi and Ishizaki, 1982) and *Galleria melonella* (Cymborowski et al., 1989, 1991) but too many gaps remain to estimate the circadian organization of the neuroendocrine systems in these insects. In addition, *Rhodnius* brain-retrocerebral complexes were found to contain and release neuropeptides related to *Bombyx* PTTH (Vafopoulou and Steel, 2002). Recombinant *Bombyx* PTTH has been shown to stimulate ecdysteroid synthesis by *Rhodnius* PGs *in vitro* suggesting that the function and conformation of PTTH may be conserved even among distantly related species (Vafopoulou and Steel, 1997). If this is the case, its role in the circadian organization of development might also be conserved. The results described above challenge the conventional view of the role of hormones as simple switches and it is now clear that hormones are not just outputs of the circadian system but are in fact integral components of the circadian system itself.

The circadian clock in the brain of larval *Rhodnius* (Fig. 3) has recently been described (Vafopoulou et al., 2010; Vafopoulou and Steel, 2012a). *Rhodnius* is the only insect, other than *Drosophila*, for which true clock cells, exhibiting circadian cycling of both PER and TIM, have been reported (Vafopoulou et al., 2010). The brain clock of larval *Rhodnius* consists of two anatomically, immunologically, and presumably functionally distinct groups of clock cells. The first is a group of 8 lateral clock neurons (LNs) located in the proximal optic lobe and the second is a larger group of dorsal clock neurons (DNs) in the posterior dorsal protocerebrum. The LNs and their axons stain

Figure 3: The circadian timing system in the brain of larval *Rhodnius prolixus* (from Vafopoulou and Steel, 2012a). See text for details. aMe, accessory medulla; DN_s, dorsal clock neurons; Ip, inflection point; La, lamina; LN_s, lateral clock neurons; mb, mushroom body; Me, medulla; PPA, primary protocerebral arborization area.

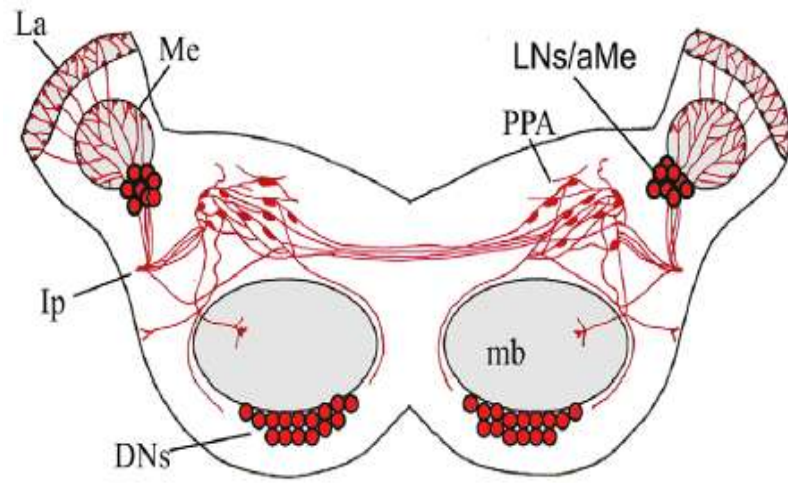

intensely with pigment-dispersing factor (PDF), allowing their axons to be traced. The DNs are devoid of PDF. Axons from the LNs project to the accessory medulla (AMe) and from there follow one of two paths: 1) laterally to the compound eye and 2) medially into a massive area of arborizations in the anterior protocerebrum (termed the protocerebral arborization area, PPA). The LNs extend two axons to the DNs and two more across the midline to the contralateral LNs, indicating that clock cells throughout the brain are integrated into a timing network. The circadian clock network in the brain of larval *Rhodnius* resembles those reported for other insects, though it rivals the complexity of most adult systems.

In *Rhodnius* the brain clock has been shown to interact substantially with the neuroendocrine system. *Rhodnius* larvae possess two PTTH cells in the lateral protocerebrum of each hemisphere (Vafopoulou et al., 2007). Axons from the LNs form close associations with PTTH cell axons, providing the neuroanatomical basis for the circadian control of PTTH release described above. Similar axonal pathways exist connecting the LNs to neurosecretory cells that produce ILPs and TE, respectively, and thereby regulate rhythmic synthesis and release of these neuropeptides (Vafopoulou and Steel, 2012b). Though axonal pathways between the clock in the brain and neurosecretory cells have only been observed from the LNs, clock control of neurohormone rhythms could be a property of the whole network or of some yet unknown part of it whose output is merely routed that way. The brain clock network ultimately controls a large number of output circadian rhythms (including behavioural rhythms), each with different phase and period properties. The regulation of these outputs

must involve various mechanisms, not necessarily within the network, about which little is presently known. The timekeeping system in the brain of larval *Rhodnius* is well placed to receive photic input from the compound eyes and to regulate rhythms of multiple peptide hormones as well as rhythmic behaviour. Thus, the *Rhodnius* brain clock is functionally analogous to the mammalian SCN (Vafopoulou et al., 2010).

JH titres have never been measured in *Rhodnius*, however the circadian control of JH has been reported in crickets (Zhao and Zera, 2004; Zera and Zhao, 2009). In *Rhodnius*, the LNs extend axons to the CA (Vafopoulou et al., 2010) and the potential for the clock control of JH synthesis therefore exists. The role of JH in the circadian system of insects remains to be elucidated. A radioimmunoassay (RIA) was developed for the detection of melatonin in small samples (Gorbet and Steel, 2003) and using this technique, melatonin was measured in *Rhodnius* hemolymph. Melatonin titres were much higher in the scotophase than in the photophase suggesting a possible daily rhythm (Gorbet and Steel, 2003). Considering the important role of melatonin in the circadian systems of vertebrates it is tempting to speculate involvement in the circadian organization of *Rhodnius*.

6.3 Analogy with the mammalian system

The PTTH-ecdysteroid axis is central to the circadian system of larval *Rhodnius* (Steel and Vafopoulou, 2006 and see Section 6.1) and is highly analogous to the mammalian hypothalamus-pituitary-adrenal (HPA) axis. The SCN in mammals and the LNs in *Rhodnius* regulate the rhythmic release of a trophic peptide hormone, ACTH and PTTH, respectively. ACTH influences rhythmic glucocorticoid synthesis by the adrenals

and PTH modulates rhythmic ecdysteroidogenesis by the PGs. Both the adrenals and the PGs possess their own circadian clock that regulates the rhythms of steroid hormone production. The adrenals and PGs also exhibit rhythms of responsiveness to ACTH and PTH, respectively. Glucocorticoids (Balsalobre et al., 2000) and ecdysteroids (Vafopoulou and Steel, 2005, 2006) subsequently act on multiple target tissues via their respective nuclear receptors to distribute timing information. Glucocorticoids have been shown to entrain peripheral clocks, but such a role for ecdysteroids has not been investigated.

Despite the profound similarities, differences do exist between the two systems. In *Rhodnius*, the PG clock can feedback to the LNs that have been shown to express EcR (Vafopoulou and Steel, 2005). In contrast the central SCN clock of mammals appears to be rather insensitive to glucocorticoids, as receptor expression was not detected in the SCN (Ahima et al., 1991; Ahima and Harlan, 1990; Balsalobre et al., 2000). However, it has been suggested that glucocorticoids may indirectly affect the SCN via serotonergic projections from the raphe nuclei (reviewed in Buijs and Escobar, 2007) and Murphy et al. (2013) have recently shown that rhythmic ovarian steroid hormones appear to influence clock gene expression in the central clock in the SCN. The rhythmic secretion of corticosterone appears to inhibit the uncoupling of peripheral clocks from the central pacemaker (Schibler and Sassone-Corsi, 2002) and ecdysteroids may play a similar role in *Rhodnius* by acting on the LNs through EcR.

Another difference involves the light input pathways to peripheral clocks. In mammals, only the SCN receives direct photic input via the RHT and must convey this

information to peripheral oscillators. In insects, peripheral clocks such as the PGs are directly photosensitive. However, a direct multisynaptic autonomic pathway connects the SCN to the adrenals (Engeland and Arhold, 2005; Buijs et al., 2006) that may transmit temporal data. The profound similarities between the mammalian and insect circadian neuroendocrine systems emphasize their vital importance to the survival of the organism. Insights into the fields of human health and medicine can therefore be gleaned from the study of the highly analogous insect system.

7. OBJECTIVES

The circadian organization of the neuroendocrine system of adult insects is not well studied (Steel and Vafopoulou, 2009; Bloch et al., 2013a). To date, only disconnected, fragmentary pieces of information are available from which no coherent description can be offered. In *Rhodnius*, during metamorphosis to the adult stage the number of PTTH-immunoreactive cells in the brain doubles (Vafopoulou et al., 2007). Axons from these PTTH cells form intimate associations with axons extending from clock cells stained with PDF (Vafopoulou et al., 2007). The brain clock system of adult *Rhodnius* has been described in detail (Vafopoulou and Steel, 2012a). Hence, the neuroanatomical substrate for circadian control of PTTH exists in adults.

Clock cell axons were also found to make close associations with axons extending from ILP- and TE-immunoreactive cells and thereby control the rhythms of these hormones in the adult (Vafopoulou and Steel, 2012b). Therefore, adult *Rhodnius* may possess as many as three neuropeptide hormones with known ecdysteroidogenic activity. Ecdysteroids are present in adult insects, though generally in smaller amounts than in

larvae, and can be produced by a variety of tissues including the gonads (Hagedorn, 1985; Brown et al., 2009). Ecdysteroids have previously been measured from hemolymph of adult *Rhodnius* (Ruegg et al., 1981). JH is also known to play a role in the endocrine control of reproductive processes in *Rhodnius* (Wigglesworth, 1936; Davey, 1981), however the specific *Rhodnius* JH has not been identified (Wyatt and Davey, 1996) and there is no practical method available to measure hemolymph titres directly. Considering that all the major hormones involved in the circadian control of larval development are present in adult *Rhodnius* it is appropriate to ask whether they maintain a similar functional relationship.

The general objective of the present work is to study the circadian organization of the neuroendocrine system of adult *Rhodnius*. In adult *Rhodnius*, feeding a single large blood meal initiates a cycle of egg development and oviposition (Buxton, 1930; Friend et al., 1965; Pratt and Davey, 1972) and can therefore be used to synchronize a population of experimental animals. Additionally, the ultimate outcome of oogenesis, egg laying, is known to be under circadian control in *Rhodnius* (Ampleford and Davey, 1989), implying the circadian regulation of the underlying physiological regulatory mechanisms. For these reasons, egg development served as a starting point for the following studies. The general objectives of this work can be subdivided into four more specific goals:

- 1) To identify and partially characterize the PTTH peptide in adult *Rhodnius*;
- 2) To investigate the pattern of its release during egg development;
- 3) To confirm the presence of ecdysteroids in adult *Rhodnius* and identify their source;

4) To examine the pattern of changing ecdysteroid levels during egg development.

Little is known about the physiological mechanisms by which circadian organization is generated in any adult insect. Additionally, circadian physiology is a current focus of investigation in mammalian systems and this work may provide insights into common principles of circadian organization across animal phyla.

CHAPTER TWO
RHYTHMIC RELEASE OF PROTHORACICOTROPIC HORMONE
FROM THE BRAIN OF AN ADULT INSECT DURING EGG
DEVELOPMENT

This chapter has been published previously in *Comparative Biochemistry and Physiology*

- Part A: Molecular and Integrative Physiology as:

VAFOPOULOU, X., CARDINAL-AUCOIN, M., STEEL, C.G.H., 2012.

Rhythmic release of prothoracicotropic hormone from the brain of an adult insect during egg development. *Comp. Biochem. Physiol. A* 161, 193-200.

M.C.-A. performed all experiments, analyzed data, and contributed to writing the manuscript.

X.V. helped with experimental design and with western blot analysis. Additionally, X.V. prepared the manuscript figures and contributed significantly to writing the manuscript.

C.G.H.S. secured funding for the project and edited the manuscript.

Prefix:

Prothoracicotropic hormone (PTTH) is a brain neurohormone that has been studied for over 80 years. The only known target of PTTH is the prothoracic glands (PGs) of larvae, which synthesize the insect molting hormones (ecdysteroids) and a massive literature exists on this axis. The PGs degenerate around the time of adult emergence, yet presence of PTTH has been reported in the brains of several adult insects. Using an *in vitro* bioassay system, we confirm that PTTH is present in the adult female brain of *Rhodnius prolixus*. The material is electrophoretically, immunologically and biologically indistinguishable from larval PTTH. The amount of PTTH in the brain shows a daily rhythm during egg development. We show that brains *in vitro* release PTTH with a daily rhythm over this period of time. PTTH is released at each scotophase. This is the first report that PTTH is released from the adult brain and functions as a hormone, inviting explanation of its function. Larval PTTH is also known to be released with a daily rhythm, and the clock in the brain controls both larval and adult rhythms. The potential significance of rhythmic PTTH release in female adults is discussed in relation to the regulation of ecdysteroids, egg development and the concept of internal temporal order.

Keywords: Bombyxin, brain clocks, endocrine rhythms, oviposition, temporal order.

1. Introduction

Prothoracicotropic hormone (PTTH) is one of the oldest known neurohormones, having been discovered by Kopeč (1922) as a brain factor necessary for pupation of the moth *Lymantria dispar*. A similar brain factor was found to be necessary for molting in *Rhodnius prolixus* (Wigglesworth 1934) that was secreted from neurosecretory cells in the brain (Wigglesworth, 1940). This factor was shown to stimulate the prothoracic glands (PGs) in both holometabolous (Willams, 1947) and hemimetabolous (Wigglesworth, 1952) insects to produce ecdysteroids, which are the moulting hormones that act on target tissues (reviewed by Raihkel et al., 2005). The brain hormone henceforth became known as PTTH. Ecdysteroids induce cellular changes during molting in almost all cells of the insect. The PTTH peptide was purified from *Bombyx mori* by Kataoka et al. (1987) and subsequently was cloned from numerous species (see references in Wei et al., 2005).

In recent years, this laboratory has shown that the PTTH-ecdysteroid axis is not merely a regulator of ecdysteroid production. It is also critical for the synchronization and coordination of cells and tissues during molting, i.e. it generates internal temporal order throughout the developing insect (reviewed by Steel and Vafopoulou, 2006). This order is accomplished by precisely timed circadian rhythmicity in both hormones. PTTH is released from the brain with a circadian rhythm (Vafopoulou and Steel, 1996a,b) under the control of circadian clock cells in the brain (Vafopoulou et al., 2007; Vafopoulou et al., 2010); these rhythmic levels of PTTH set the phase of (i.e. entrain) a second circadian clock located in the PGs (Pelc and Steel, 1997), which generate a circadian rhythm of

synthesis and release of ecdysteroids (Vafopoulou and Steel, 1989, 1991). The resulting circulating steroid rhythm conveys circadian time information to diverse target tissues that lack the ability to measure time via induced cycling of the receptors for ecdysteroids (Vafopoulou et al., 2005; reviewed by Vafopoulou and Steel, 2006; Vafopoulou, 2009). Consequently, numerous different target tissues become synchronized both with each other and with the external world. Overall, these studies established the PTTH-ecdysteroid axis as the central mediator of circadian organization during insect development (reviewed by Vafopoulou and Steel, 2009).

Circadian organization is equally important in the adult stage, yet almost no evidence exists regarding how this is achieved. The PGs cannot be involved since they degenerate around the time of adult emergence (Wigglesworth, 1955). Ecdysteroids are present in adult insects, but at much lower levels than in larvae and their source seems to vary between species (reviews by Raihkel et al., 2005; Brown et al., 2009). This degeneration of the only known target of PTTH encouraged the assumption that PTTH was a larval hormone. However, there is evidence that PTTH is present in adults, although its function is unknown. The purification of PTTH from *Bombyx* (Kataoka et al., 1987) employed heads of adult moths. PTTH immunoreactive neurons are present in the brain of *Rhodnius* in the same position as in larvae and, remarkably, the adult brain possesses double the number of PTTH cells compared to the larval brain (Vafopoulou et al., 2007). Bioassayable PTTH activity is present in brains of *Manduca sexta*, for at least a week after emergence (Rybczynski et al., 2009). PTTH mRNA is expressed in the brains of *Drosophila melanogaster* (McBrayer et al., 2007) and *Culex pipiens* (Zhang and

Denlinger, 2011), but the presence of PTTH peptides was not examined in either species. Collectively, these reports indicate that PTTH is present in the adult brains of diverse insect species. However, it is critical to note that no study has shown that PTTH is actually released from the adult brain into the circulation.

In the present paper, we show that the brain of adult *R. prolixus* contains a neuropeptide that is electrophoretically and immunologically closely similar to larval PTTH. We demonstrate that this peptide is released from the brain *in vitro*. Moreover, this release occurs with a daily rhythm throughout the period of egg development, confirming that the brain clock maintains control over PTTH release in the adult stage. The similarity of this rhythm of PTTH release in adults with that seen previously in larvae (Vafopoulou and Steel, 1996a,b) sets the stage for exploration of the relationships between PTTH and ecdysteroids in the adult and the roles of these hormones in the circadian organization of the adult insect.

2. Materials and methods

2.1 Animals and tissues

Female adult *R. prolixus* Stål (Hemiptera) were reared in a 12 h light:12 h dark regime at 28 ± 0.5 °C. A single blood meal triggers one cycle of egg development and synchronizes the experimental population; the day of feeding is referred to as day 0. Females that have completed one egg production cycle (i.e. second cycle females) were used throughout. Brain complexes with the optic lobes attached (including corpus cardiacum and corpus allatum) were excised 4 times a day at 1 h and 7 h after lights-off and at 1 h and 7 h after lights-on. Five animals were sampled at each time point. For PG

donors, male fifth instar larvae were reared at 28 ± 0.5 °C in continuous light (LL) for at least 3 weeks prior to a blood meal, in order to abolish the intrinsic rhythmicity of ecdysteroid synthesis by PGs (Vafopoulou and Steel, 1993). Development to the adult was initiated by a blood meal. Larvae were staged from the day of feeding, which was called day 0. Ecdysis to the adult stage peaks on day 21 after a blood meal. PGs were dissected from animals on day 7 after feeding.

2.2 *In vitro* bioassay for PTTH activity

The bioassay for PTTH activity was performed according to established protocols (Vafopoulou et al., 1996; Vafopoulou and Steel, 1996a,b). It compares the synthesis of ecdysteroids *in vitro* by one member of a PG pair incubated in medium containing PTTH activity to that of the contralateral member from the same animal in medium alone. PTTH activity was measured in both brain extracts and incubation media of brain complexes. First, the activity of PTTH was determined in brain complexes freshly excised from animals throughout the second egg production cycle. Brain complexes were excised under *Rhodnius* saline (Lane et al., 1975) and were individually homogenized immediately in 25- μ L saline and then heated at 100 °C in a water bath for 3 min. The extract was then centrifuged at 10,000 g for 10 min and the supernatant was stored at -80 °C until further use. Second, brain complexes were incubated *in vitro* and the PTTH activity that was released into the incubation medium was measured. Each complex was washed thoroughly in saline and then incubated in 100 μ L of the solution for 4 h. Incubations were performed in room lighting when the donor animal was in the photophase and in darkness when the donor animal was in the scotophase. After the end

of incubation, the media were heated to 100 °C for 2 min and stored at –80 °C until further use.

The PTTH activity of brain extracts and incubation media was assayed by its ability to augment synthesis of ecdysteroids by arrhythmic male fifth instar *Rhodnius* PGs *in vitro* (Vafopoulou et al., 1996; Vafopoulou and Steel, 1996a). PTTH-induced stimulation of ecdysteroid synthesis derives entirely from brain peptide(s) that are either released or extracted from brain complexes and the specificity of the response has been documented in dose–response protocols (Vafopoulou et al., 1996). Day 7 PGs were used in this assay since PGs are most responsive to PTTH on this day (Vafopoulou et al., 1996). PGs were excised under saline. Left and right members of a pair of PGs synthesize ecdysteroids at highly comparable rates (Vafopoulou and Steel, 1989). Therefore, one member of each pair of PGs was incubated for 4 h with either the extract of one brain or the medium from the incubation of one brain, while the contralateral PG provided a control and was incubated in saline alone. Both experimental and control pairs were incubated *in vitro* for 4 h, since PTTH stimulated ecdysteroid synthesis is linear for at least 4 h (Vafopoulou et al., 1996).

The PTTH activity of test samples was evaluated by comparison of ecdysteroid synthesis of PTTH-stimulated PGs with their contralateral untreated controls. Because ecdysteroids are not stored by the PGs, ecdysteroids in the medium result from synthesis (Vafopoulou and Steel, 1989). Ecdysteroids were then quantified by radioimmunoassay (RIA) (see below). The degree of stimulation of synthesis by test medium was evaluated using two complementary methods. (i) The difference in amount of synthesis [ng of 20-

hydroxyecdysone (20E) equivalents/4 h] between treated and control members of each PG pair was calculated and expressed as mean difference \pm SEM for a group of 5 pairs.

(ii) These differences in synthesis in a group of pairs were compared using the paired sample t-test (two-tailed), and the resulting t value was plotted as a Stimulation Index (SI) (Vafooulou et al., 1996). SI reveals the level of significance of the stimulation calculated in the first method.

2.3 Ecdysteroid RIA

The ecdysteroid RIA was performed as previously described (Steel et al., 1982; Vafooulou and Steel, 1989) using the H-21B antiserum (produced by Horn et al., 1976) and α -[23,24-³H(N)]ecdysone (sp. act. 110 μ Ci (4.07 TBq)/mmol) (PerkinElmer, Billerica Mass) as the labeled ligand. The antiserum was a kind gift from Dr. Ernest S. Chang (University of California, Davis) and has greater affinity for 20-hydroxyecdysone (20E) than ecdysone. The *Rhodnius* PG cells are arranged on the surface of the paired inner lobes of the thoracic fat body (Wigglesworth, 1952). Because of this intimate connection of the PGs cells and the inner lobes, the whole lobe with the PG cells is dissected and incubated in vitro as described by Vafooulou and Steel (1989). The major ecdysteroid found in the incubation medium is 20E not ecdysone (Vafooulou and Steel, 1989; 1993). 20E was used as the standard, hence the results are expressed as ng 20E equivalents.

2.4 SDS-PAGE and Western blots

PTTH extraction was carried out by homogenization of brain complexes in saline in the presence of 2 mM phenylmethylsulphonyl fluoride and 1 mg/mL trypsin inhibitor.

PTTH extracts were prepared from batches of 30 brain complexes at 4 °C. The extracts were immediately heated at 100 °C in a water bath for 3 min. Homogenates were centrifuged at 5000 g for 15 min and the supernatants were recovered. Incubation media were prepared by incubating 30 brain complexes for 4 h at room temperature in 100- μ L saline. Both media and brain extracts were frozen at -80 °C until further use. Prior to SDS-PAGE, both brain extracts and incubation media were desalted by centrifugation using Amicon Ultra-0.5mL (Millipore, Billerica, MA, USA).

Ten percent SDS-PAGE was performed using standard procedures. Kaleidoscope standards (Bio-Rad, Hercules, CA, USA) were used to estimate the relative molecular size of separated peptides. Proteins from unstained gels were transferred onto PVDF membranes electrophoretically at 300 V for 1 h at room temperature. Filter papers were washed 3 times in 50 mM Tris-HCl buffered saline (TBS), pH 7.6 and blocked with 0.05% normal serum and 0.05 g/ml dried milk for 1 h. Filter papers were then washed in 0.05% Tween 20 (w/v) in TBS and probed for 2 h with an antibody against PTTH at 1:1000 dilution. This mouse monoclonal antibody for PTTH was prepared against a synthetic fragment that corresponds to amino acids 1–15 at the N-terminal of Bombyx PTTH (see Mizoguchi et al., 1990) and was a kind gift from Dr. A. Mizoguchi (Nagoya University, Nagoya, Japan). This antibody recognizes specifically both *Rhodnius* PTTH in brain extracts and released material in larvae (Vafopoulou and Steel, 2002) and the PTTH neurons in both larval and adult brains (Vafopoulou et al., 2007). After 3 washes in 0.05% Tween 20 TBS, the filters were incubated for 2 h with secondary antibody, horseradish peroxidase conjugated goat anti-mouse IgG (Sigma-Aldrich, St. Louis, MO,

USA) at 1:200 dilution. Following 3 washes in 0.05% Tween 20 in TBS and a final wash in TBS, immunoreactive material was revealed with 3,3-diaminobenzidine hydrochloride as a peroxidase substrate and H₂O₂. All incubations were performed at room temperature.

2.5 Removal of PTTH activity by double immunoprecipitation

Peptides in incubation media from day 5 brain complexes of female adults in scotophase were concentrated and partially purified by ultrafiltration using Amicon Ultra-0.5 ml (Ultracel-PL membrane) centrifugal tubes (Millipore, Billerica, MA, USA). First, media from 15 brains were centrifuged in batches of 5 using a 100 kDa filter membrane. The retentates were discarded to remove peptides >100 kDa and the filtrates were re-centrifuged using a 50 kDa filter membrane to remove peptides <50 kDa. All retentates which contained peptides in the range of 50-100 kDa were pooled, reconstituted to 100 µL with TBS and divided into two halves; one half was allowed to react with anti- PTTH for 24 h at 4 °C. The antibody was used at a dilution of 1:100. Then an equal volume of anti-mouse IgG bound to agarose (Sigma- Aldrich) was added to the mixture which was allowed to react for 2 h at room temperature with shaking. The second half of the retentate served as control and was allowed to react with an equal volume of control mouse serum bound to agarose (Sigma-Aldrich) for 2 h at room temperature with continuous shaking. Supernatants were removed following brief centrifugation at 1000 g for 15 s and were brought to final volume of 100 µL/brain with saline. PTTH activity in these supernatants was assayed in vitro as described in Section 2.2.

3. Results

3.1 Electrophoretic profile of PTTH in female adults

The electrophoretic profiles of peptides with PTTH immunoreactivity in brain complexes and in incubation media in the female adult brain were examined on Western blots (Fig. 4). These brain complexes were excised from day 6 animals after a blood meal at 7 h after lights-off (middle of scotophase); at this time of day, brain complexes release significant PTTH activity in vitro unlike in photophase when they release minimal amounts (see Fig. 8). Likewise, brain extracts were prepared from brain complexes of day 6 animals in photophase; at this time, brain complexes do not release significant amounts of PTTH activity (see Fig. 8). Blots were probed with the antiserum against PTTH.

Western blot analysis of peptides released into incubation media from scotophase brain complexes and separated electrophoretically under non-reducing conditions (without β -mercaptoethanol) revealed the presence of a single peptide that was immunoreactive to the antibody at approximately 68 kDa (Fig. 4, lane B). The size of this immunoreactive peptide is closely similar to the size of the PTTH peptide released in vitro by brain complexes of larvae (Vafopoulou and Steel, 2002). In adults, this peptide was absent from blots of media of photophase brain complexes of day 6 females (data not shown) showing clearly that it is released with a daily rhythm. In contrast, brain extracts from photophase animals also separated under non-reducing conditions revealed the presence of three immunoreactive peptides at approximate positions 68 kDa, 48 kDa and 32 kDa (Fig. 4 lane A). The 68 kDa peptide co-migrates with the immunoreactive peptide found in incubation media and thus very likely represents the intact PTTH related molecule in adults. The smaller size immunoreactive peptides on the other hand, may represent various degrees of subunit polymerization or progressive proteolysis of the 68

Figure 4: Western blot of extract from adult female brain complexes during the photophase (A) and of incubation media from brain complexes during the scotophase (B). Proteins were separated in 10% SDS-PAGE (non-reducing conditions) and probed with the PTTH antibody. Each lane represents brain extracts or media from 30 brain complexes. Arrows at left mark the positions of immunoreactive peptides.

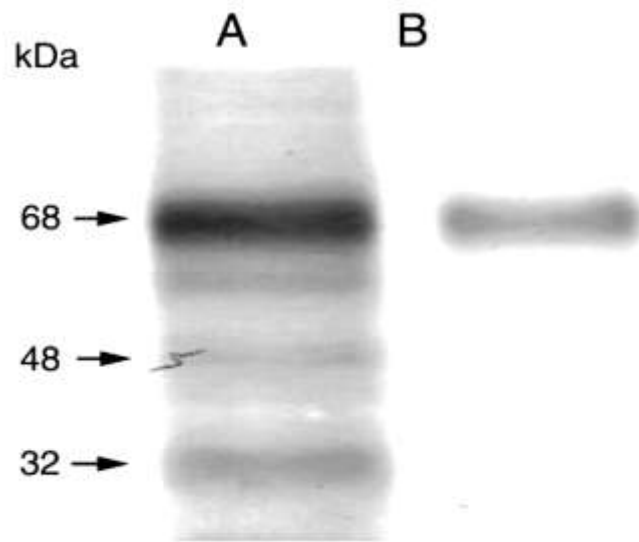

kDa peptide to smaller size molecules. Very similar additional bands were also observed in the electrophoretic profiles of immunoreactive peptides from larval brain extracts (Vafofoulou and Steel, 2002). We conclude that both adult and larval *Rhodnius* possess PTTH peptides of similar relative size and immunoreactivity.

3.2 Removal of PTTH activity in incubation media by double immunoprecipitation

The PTTH activity in the 50–100 kDa peptide fraction that was separated by ultrafiltration from incubation media from day 5 brain complexes from female adults in scotophase was abolished by double immunoprecipitation using the PTTH antibody and agarose-bound anti-mouse IgG (Fig. 5). Antigen-antibody complexes bound to agarose were removed by centrifugation and the supernatant was tested for PTTH activity on one member of a PG pair (Fig. 5A). The contralateral member of the pair incubated in a supernatant which was produced after centrifugation of medium in which the 10–100 kDa peptide fraction was double immunoprecipitated with anti-PTTH and control mouse serum bound to agarose (Fig. 5B). As controls, the PTTH activity of unfractionated incubation medium from day 5 adult females in scotophase was tested on one member of a PG pair (Fig. 5C), while the contralateral member of this pair was incubated in the absence of medium to show the basal ecdysteroid synthesis of unstimulated PGs (Fig. 5D).

As shown in Fig. 5, agarose-bound control anti-mouse IgG did not affect the PTTH activity in the fractioned supernatant and PGs were stimulated to synthesize closely similar amounts of ecdysteroids to PGs which were treated with whole, unfractionated medium (compare A and C; $p>0.05$). In contrast, the fractioned supernatant

Figure 5: Stimulation of PG ecdysteroid synthesis by PTTH released *in vitro* by brain complexes of day 5 female adults in scotophase (A–C). Each PG was treated with incubation medium from a single brain complex. A represents synthesis by one member of a PG pair and B represents synthesis by the contralateral member of the pair. C represents synthesis of one PG member of a pair and D represents synthesis by the contralateral member. A. Incubation media containing peptides at 10–100 kDa range treated with agarose-bound control mouse IgG. B. Double immunoprecipitation of incubation media containing peptides at 50–100 kDa range treated with anti-PTTH as primary antibody and anti-mouse IgG bound to agarose as secondary antibody. Note the removal of ecdysteroid stimulation by double immunoprecipitation of PTTH. C. Unfractionated incubation media of whole brains. D. Untreated, unstimulated control PGs. Each bar represents the mean \pm SEM of ecdysteroid synthesis by 15 PGs from 30 animals.

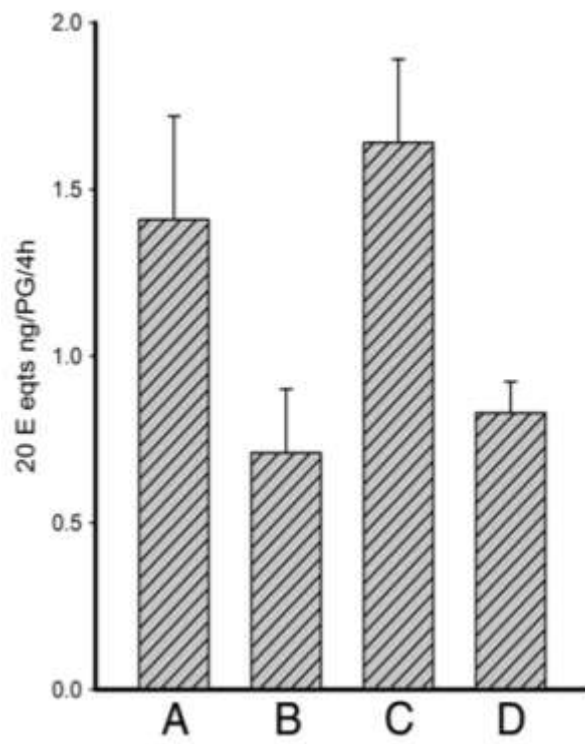

lost all its PTTH activity when it was treated with agarose-bound anti-mouse IgG and the levels of ecdysteroid synthesis by PGs were very similar to those produced by control, untreated PGs (compare B and D; $p>0.05$). Supernatants in A stimulated ecdysteroid synthesis by PG significantly when compared to both their contralateral PGs in B and to control, untreated PGs in D ($p<0.005$ in both comparisons). Likewise, PGs treated with unfractionated medium in C were significantly stimulated when compared to their contralateral, untreated PGs in D, as well as the PGs in B ($p<0.005$ in both comparisons). In general, PGs stimulated by either unfractionated medium (C) or medium containing peptides in the range of 50–100 kDa (A) synthesized about twice as much ecdysteroids relative to control PGs (either untreated [D] or treated with medium in which PTTH was removed [B]). It is concluded that the PTTH antibody recognizes the PTTH activity released by female adult brains in incubation media as it does in larvae (Vafopoulou and Steel, 2002).

3.3 Egg development

Female adult *Rhodnius* maintain their complement of oocytes in a state of developmental arrest until given a blood meal, which initiates a cycle of egg development and oviposition (see Section 4.3). Egg development was measured by both ovary weight (OW) and terminal oocyte length (TOL). It was found that both OW and TOL began to increase on day 3 after a blood meal (Fig. 6). TOL reached a maximum at day 4 and maintained a plateau at this length throughout oviposition. Ovaries continued to increase in weight until day 6. The minor variations in ovary weight from days 6 to 13 are not

Figure 6: Wet ovary weight (●) and terminal oocyte length (○) during egg development. Ovaries were collected once a day in scotophase. Note the sharp increase in both ovary weight and terminal oocyte length after feeding starting at day 3 and forming a plateau from days 6 to 14. Hatched bar shows period of oviposition. Points represent means± SEM of 5–15 animals.

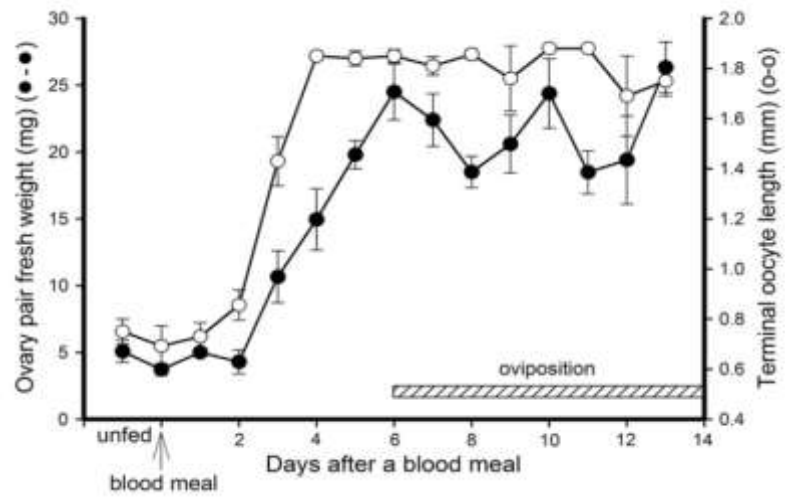

statistically significant. Therefore, ovary weight maintains a plateau level from day 6 onwards. Oviposition commenced on day 6 and declined from day 13 onwards.

3.4 PTTH content of brain complexes throughout an egg development cycle

The PTTH content of brain complexes was determined at frequent intervals throughout an egg development cycle. The objective was to relate changes of PTTH activity in the brain to specific times during the cycle. For this purpose, dissection of brain complexes from female adults was carried out at 6 h intervals starting from the day before a blood meal, until day 9 after a blood meal (Fig. 7), when oviposition begins to slow down. The activity of PTTH in brain extracts is presented in two complementary forms, first as the numerical amount of stimulation (upper panel) and second as the statistical significance of stimulation (SI) (lower panel). An SI of zero signifies that control and test PGs are indistinguishable, whereas an SI of 2.7 signifies that the released PTTH significantly stimulated ecdysteroid synthesis by test PGs above that of contralateral (control) PGs at the level of $p=0.05$ (Figs. 7 and 8). Both methods of presentation show the same trends.

Unfed adult brain complexes contained abundant biologically active PTTH. This material was rapidly depleted following a blood meal, when the content was reduced sharply by the beginning of the scotophase of day 1 (Fig. 7A), when the SI value became insignificant (Fig. 7B). These findings suggest prompt release of PTTH activity after feeding. However, PTTH levels were restored on day 1 almost to levels seen before feeding, suggesting rapid synthesis of PTTH. From days 1–3 the level of PTTH content remained relatively constant with no discernible times of significant decrease or increase.

Figure 7: Changes in PTTH content of female adult brain complexes during egg development. Extract from each brain complex was assayed by its ability to augment ecdysteroid synthesis by one member of a pair of PGs. (A) Data are expressed as synthesis by treated PG minus the synthesis of the untreated contralateral member of each pair of PGs. Points are means \pm SEM of differences for a group of 6 pairs of PGs. (B) Levels of significance of the stimulation shown in (A) obtained using the paired sample t-test and expressed as a stimulation index (SI) (see Materials and methods). Values of SI above the line at $P=0.05$ indicate that the PTTH content induced significant augmentation of ecdysteroid synthesis above that of contralateral (control) PGs. Note that the unfed brain contains significant levels of PTTH activity and feeding triggers a prompt significant decrease in activity. Note the presence of a clear daily rhythm in PTTH content with high stimulation during each photophase of days 3–9 and low stimulation during each scotophase. Dark bars indicate scotophases and white bars indicate photophases.

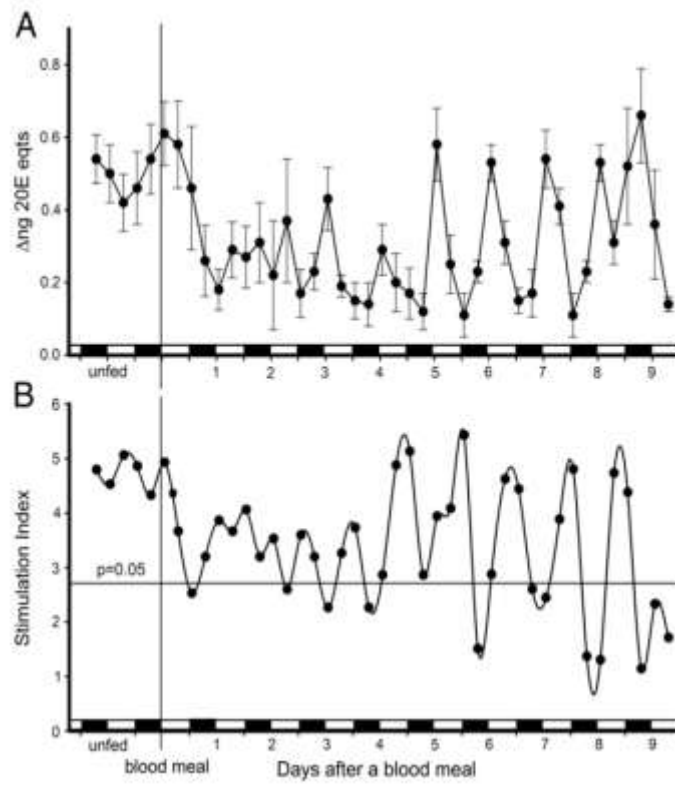

However, from day 3 until day 9 a clear daily rhythm in PTTH content of brain complexes became evident, characterized by high amounts of PTTH activity every photophase and low amounts every scotophase. Significant stimulation is obtained only with photophase brains but not with scotophase brains (Fig. 7B), suggesting rhythmic depletion of activity every scotophase during days 3–9. This rhythmicity in PTTH content parallels the duration of egg development and oviposition (compare with Fig. 6).

3.5 Rhythmic PTTH release from the adult female brain

The release of PTTH from brain complexes was examined at the end of 4 h incubation *in vitro*. Incubations were performed every 6 h throughout days 0–9 after feeding and in unfed animals (Fig. 8). Complexes from unfed animals showed nominal release of PTTH (0.02 ng 20E eqts). This amount was considered a ‘basal release’ and was included in Fig. 8 as a straight horizontal line for comparison to the times when PTTH release was greatly increased. Feeding triggered a massive release of PTTH from the complexes into the incubation medium, which peaked during the early scotophase of day 1 (Fig. 8A) and resulted in significant stimulation (Fig. 8B). Release was maintained from days 1–3 with no significant fluctuations. From day 3 until day 9 the incubation media from scotophase complexes were highly stimulatory resulting in high numerical differences in synthesis of ecdysteroids between stimulated and contralateral (control) PGs, whereas media from photophase complexes produced minimal values close to basal release (Fig. 8A). The scotophase media during these days elicited highly significant stimulation, whereas release from photophase complexes was never significant (Fig. 8B). Therefore, the release of PTTH from brain complexes of female adult *Rhodnius* exhibits a

Figure 8: Daily rhythm of release of PTTH from female adult brain complexes during egg development on days 3–9 after a blood meal. PTTH release was assayed at 6 h intervals and expressed (A), as mean increase (\pm SEM of $n=5$ separate determinations) in ecdysteroid synthesis of test PGs (PTTH-stimulated) above contralateral (control; not stimulated) PGs and (B), as Stimulation Index (SI) values derived from the statistical analysis of the data in (A). Data points above the line at $P=0.05$ represent significant amounts of PTTH. Note the absence of release in unfed animals and prompt release after feeding. Note that an increase in numerical stimulation (A) occurs to statistical significance (B) in scotophase (dark bars) but not in photophase (open bars), indicating that significant release of PTTH occurs during the scotophase but not the photophase on days 3–9.

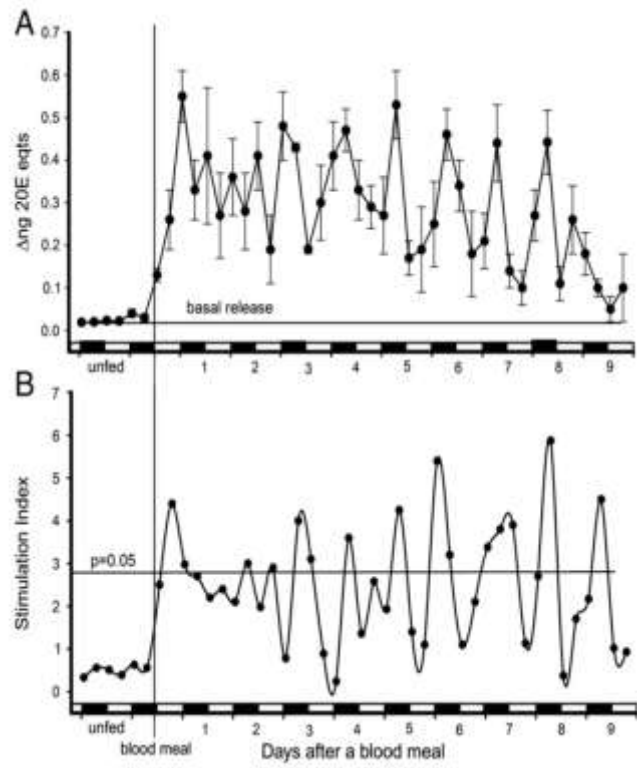

pronounced daily rhythm with significant amounts of PTTH being released each scotophase and minimal amounts during the photophase. These days represent the time of active egg development in the ovaries (see Fig. 6). At day 9, the amplitude of the daily peak of PTTH release was reduced (Fig. 8A) in parallel with the reduction of PTTH content in the brain (Fig. 7A), both of which coincide with the onset of declining oviposition.

4. Discussion

4.1 Comparison of PTTH from adult female and larval brains

The cerebral neuropeptide PTTH is central to the regulation of development and growth in insects. Its primary action is to act on the paired PGs where it modulates the synthesis of ecdysteroids (review by Rybczynski, 2009). Ecdysteroids are released into the hemolymph and act on numerous target tissues to elicit diverse cellular responses necessary for molting and development (Riddiford et al., 2003). In *R. prolixus* larvae it was reported using an in vitro bioassay that PTTH is released with a robust daily rhythm (Vafopoulou and Steel, 1996a), which is under circadian control (Vafopoulou and Steel, 1996b) throughout an entire molt cycle. This rhythmic release results in a rhythm in the PTTH titer in the haemolymph (Vafopoulou and Steel, 1996a). The brain of adult *Rhodnius* also contains biologically active PTTH (Vafopoulou et al., 1996) that was localized by immunohistochemistry to a few neurons in the brain (Vafopoulou et al., 2007) raising the prospect that PTTH might play a role in adult specific processes such as reproduction. We report here that the adult female brain contains sufficient amounts of PTTH activity to stimulate steroidogenesis by PGs throughout a cycle of oocyte growth,

using the same in vitro bioassay which was used in larvae to identify PTTH. The adult female brain contains a peptide of closely similar molecular mass to the larval PTTH in immunoblots using a specific antibody against *Bombyx* PTTH. *Bombyx* PTTH was the first PTTH molecule that has been fully sequenced and cloned (reviewed by Ishizaki and Suzuki, 1994). PTTHs with high homology to *Bombyx* PTTH have been found in other species (review by Rybczynski, 2009) and *Bombyx* PTTH is considered a member of the superfamily of vertebrate growth factors (Noguti et al., 1995). In both larva and adult female of *Rhodnius*, these immunoreactive peptides contained in the brain were of about 68 kDa, 48 kDa and 32 kDa (Vafopoulou and Steel, 2002 for larva and present data for adult); in the larva, all bands were considered to be multiples of 17 kDa subunits. Similar molecular mass PTTH peptides were also recognized by the same antibody in *Bombyx* (reviewed by Ishizaki and Suzuki, 1994). The PTTH cells have been immunolocalized in the brain of both larva and adult *Rhodnius* (Vafopoulou et al., 2007). In the larva, two closely apposed cells are located in the lateral protocerebrum; these cells are retained in the adult. Two more PTTH positive cells appear near the larval pair of PTTH cells in the adult (Vafopoulou et al., 2007). All these cells possess long axons full of immunoreactive material showing active transport of PTTH to release sites. Therefore, the brains of both larva and adult female *Rhodnius* contain peptides that are immunologically and electrophoretically similar to *Bombyx* PTTH. It is suggested that the 68 kDa peptide represents the native *Rhodnius* PTTH in both larvae and adults. Two lines of evidence support this claim. First, the PTTH antibody removed all biological activity from the *Rhodnius* PTTH assay in both larvae (Vafopoulou and Steel, 2002) and adult females

(present data) and second, it recognized a very small number of cells in the lateral brain of *Rhodnius* in both larvae and adults, which are the source of PTTH (Vafopoulou et al., 2007). It is concluded that both larva and adult contain steroidogenic peptides of similar molecular size and immunologic relatedness to *Bombyx* PTTH.

4.2 Rhythmicity in adult female brain content of PTTH

Large and significant changes occur in the content of PTTH activity in the female adult brain at precise times after a blood meal. Unfed female adults of *Rhodnius* are in a state of reproductive arrest but their brains contain abundant biologically active PTTH that remained relatively constant in amount throughout a day. When a cycle of reproductive development is initiated by a blood meal, the PTTH content of adult female brain changes drastically. Feeding induces a prompt and significant depletion of PTTH from the brain. If PTTH plays a role in reproductive development, it seems appropriate for the unfed insect to maintain a store of PTTH in a state available for immediate release. A parallel can be drawn between the larval and adult stages. Unfed larvae exist in a state of developmental arrest but development is initiated promptly by a blood meal. A similar significant reduction in the content of biologically active PTTH in the brain was observed in the larval brain after feeding (Vafopoulou et al., 1996), suggesting that feeding triggers a strong release of PTTH in both larva and adult (see Section 4.3). The amount of PTTH in the brain is restored within two days after feeding. The presentation of the data in two complementary forms, one expressed as numerical amounts of stimulation and the second presented as ‘stimulation index’ resulted in similar trends. These methods of presentation have been used extensively before (Vafopoulou et al.,

1996; Vafopoulou and Steel, 1996a,b) and when applied in the present study revealed a striking daily rhythm in PTTH content in the brain from days 3 to 9, in other words during the period when oocyte development occurs and oviposition begins. This daily rhythm is characterized by high peaks during each photophase and low troughs during each scotophase. Similar daily rhythmicity in PTTH content was also observed in the larval brain (Vafopoulou and Steel, 1996a). These tandem changes in the content of PTTH from high to low during the course of a day are strongly suggestive of daily release of PTTH during a day. These changes are readily interpreted in terms of the relative levels of synthesis, transport and release of PTTH. About half of the PTTH content of the brain was released each scotophase and was replenished apparently by synthesis in the photophase, generating a rhythm in the amount of PTTH in the brain. Further, the PTTH neurons in the adult brain display a clear daily rhythm in the abundance of PTTH as indicated by quantitative changes in immunofluorescence due to PTTH (Vafopoulou et al., 2007).

Another neuropeptide in the brain of adult female *Rhodnius* with steroidogenic activity is bombyxin. Bombyxin is an insulin-like peptide that is reported to function as a growth or carbohydrate metabolic factor and gonadotropin (Nagasawa et al., 1984; Fullbright et al., 1997; Satake et al., 1997; Masumura et al., 2000; Nijhout et al., 2007). Bombyxin is released rhythmically from the brain of *Rhodnius* in synchrony with the rhythm of PTTH (Vafopoulou and Steel, 1997; 2002). Although bombyxin exerts a very mild stimulatory activity on PGs *in vitro*, it is effective only at 40-fold higher concentration than PTTH (Vafopoulou and Steel, 1997). The only other ecdysiotropin

known in *Rhodnius* is testis ecdysiotropin, and this has no action on PGs (Vafopoulou and Steel, 2005) and therefore could not account for the present findings.

4.3 Rhythmicity of PTTH release by the adult female brain

This report is the first demonstration that PTTH present in the brains of adults is released. Demonstration of release implies that PTTH is a circulating hormone in adults and raises questions concerning its physiological function(s). We have shown here that the adult female brain releases immunoreactive PTTH in vitro following a blood meal. This shows that PTTH is released from the adult female brain and hence may play a biological role in the adult stage. The released material is immunologically and electrophoretically indistinguishable from the larval PTTH (Vafopoulou and Steel, 2002). It also augments ecdysteroid synthesis by PGs and therefore possesses the biological activity of larval PTTH.

The release of PTTH from the brain complex occurs with a pronounced daily rhythm throughout most of the period of egg development, i.e. days 3–9 after a blood meal. Release was maximal during each scotophase and minimal during each photophase. Release during the scotophase is accompanied by depletion of the PTTH content of the brain during each night; the content of PTTH is replenished during the photophase, presumably by PTTH synthesis in the daytime. A similar rhythm of PTTH release was shown in larvae (Vafopoulou and Steel, 1996a).

The rhythmic release of PTTH from the brain continues for at least days 3–9 after feeding. It is striking that this period of time corresponds to the period of time when eggs develop after a blood meal. Female adult *Rhodnius* maintain their complement of oocytes

in a state of developmental arrest until consumption of a blood meal initiates a cycle of egg development and oviposition (Buxton, 1930; Friend et al., 1965; Pratt and Davey, 1972). It is noteworthy that the onset of PTTH rhythmic release coincides with the beginning of egg development. We suggest that PTTH in the female adult may target phenomena related to egg development. Our laboratory has shown that ovaries release ecdysteroids *in vitro* and that this release occurs with a daily rhythm that is in synchrony to PTTH release (Chapter 4, Cardinal-Aucoin et al., 2013). Steroidogenesis by the ovaries has been demonstrated in other species (e.g. Hagedorn et al., 1975; Warren et al., 1996). Since PTTH is a steroidogenic neuropeptide in larvae, it is possible that it may play a similar role in the adult females. The possibility that PTTH regulates ecdysteroids in adults remains to be investigated.

4.4 Clock control of PTTH

The complex neuroanatomy of the central circadian clock system in the brain has been described in detail for both larvae (Vafopoulou et al., 2010) and adults (Vafopoulou and Steel, 2012a) in *Rhodnius*. In both stages, elaborate axonal associations were seen of clock cell axons with the PTTH neurons, providing direct evidence that the rhythmic release of PTTH in both larvae and adults is driven by the clock in the brain. Similar associations are also seen in the axons of neurons containing bombyxin-like peptides (Vafopoulou and Steel, 2012b) (see below). The complexity of these axonal associations attests to the fundamental importance of control of neuropeptide rhythms by the brain clock. In the larva, the rhythm in PTTH acts as a key ‘messenger of time’ conveying temporal information from the brain to diverse cells and tissues that lack access to such

information. The PTTH rhythm does this by regulating the rhythm of ecdysteroid synthesis in the PGs (reviewed by Steel and Vafopoulou, 2006). The rhythm is read by nearly all cells in the insect via circadian cycling of the ecdysteroid receptor (Vafopoulou and Steel, 2006). However, ecdysteroids in the adult stage occur at much lower concentrations and its targets are frequently unclear so, ecdysteroids are unlikely mediators of internal temporal order in the adult. Now we have shown that PTTH is released as a hormone in adult females, it becomes appropriate to search for potential targets. It is possible that in adult females, the rhythmic release of bombyxin-like peptides, also controlled by the brain clock (Vafopoulou and Steel, 2012b) may be an additional important mediator of temporal order. Bombyxin is an insulin-related peptide (reviewed by Iwami, 2000) with a great diversity of targets, including ovarian development (Fullbright et al., 1997), sugar metabolism (Satake et al., 1997; Masumura et al., 2000) and haematopoiesis (Nakahara et al., 2006), making it appropriate for distribution of temporal information. Further, it is known to act synergistically with ecdysteroids (Nijhout and Grunert, 2002; Nakahara et al., 2006; Nijhout et al., 2007), raising the possibility that bombyxin, PTTH, and ecdysteroids could all be involved in mediating temporal order in adults.

CHAPTER THREE
CIRCADIAN CONTROL OF PROTHORACICOTROPIC HORMONE IN
AN ADULT INSECT AND THE INDUCTION OF RHYTHMICITY BY
LIGHT CUES

This chapter represents a manuscript in preparation:

CARDINAL-AUCOIN, M., STEEL, C.G.H.

Circadian control of prothoracicotropic hormone in an adult insect and the induction of rhythmicity by light cues

M.C.-A. performed all experiments, analyzed data, and wrote the manuscript.

C.G.H.S. secured funding for the project and helped edit the manuscript.

Prefix:

The insect neuropeptide prothoracicotropic hormone (PTTH) is a critical regulator of larval development. Our lab has recently demonstrated that PTTH is present in adult *Rhodnius prolixus* and is released by brains *in vitro* with a clear daily rhythm during egg development (Vafopoulou et al. 2012). Here, we show that the daily rhythm of PTTH release by brains *in vitro* is under circadian control since it persisted in aperiodic conditions with a free running period of around 24h that is temperature compensated. Prolonged exposure (3 weeks) of insects to continuous constant light (LL) completely eliminated PTTH release. Transfer of such insects from LL to constant darkness (DD) rapidly induced rhythmic PTTH release. Taken together, these results suggest that PTTH in adults is regulated by a photosensitive circadian clock in the brain. Moreover, PTTH was identified in the hemolymph and shown to cycle with a daily rhythm that persisted in DD and was synchronous with the rhythm of PTTH release by brains *in vitro*. We conclude that a photosensitive clock in the brain regulates rhythmic PTTH release and thus generates the rhythm seen in the hemolymph. These results emphasize the importance of rhythmic PTTH release in the adult insect and support a role for PTTH as a functional neurohormone in adult physiology and within the adult circadian system.

Keywords: adult circadian system, circadian rhythm, ecdysiotropic, endocrine rhythm, induction, insulin-like peptides, prothoracicotropic hormone.

1. Introduction:

The brain neuropeptide prothoracicotropic hormone (PTTH) was first described by Kopeč (1922) as a brain factor required for pupation in *Lymantria dispar*. Wigglesworth (1934) reported a similar brain factor necessary for moulting in *Rhodnius prolixus* and identified the specific neurosecretory cells involved (Wigglesworth, 1940). In the ensuing decades PTTH has been extensively studied and its role in the regulation of larval development in insects has been well established (Rybczynski, 2009). PTTH stimulates the prothoracic glands (PGs) to produce ecdysteroids, the insect molting hormones, which subsequently act on nearly all larval tissues to direct the cellular changes that characterize development (Raikhel et al., 2005).

In larval *Rhodnius*, the PTTH-ecdysteroid axis is a central component of the circadian system that synchronizes and coordinates numerous cells and tissues during larval development, i.e. it produces internal temporal order throughout the developing insect (reviewed by Steel and Vafopoulou, 2006). This temporal order is accomplished by precisely timed circadian rhythmicity in both PTTH (Vafopoulou and Steel, 1996a, 1996b) and ecdysteroids (Ampleford and Steel, 1985; Vafopoulou and Steel, 1989, 1991) generated by clocks in the brain (Vafopoulou et al., 2007; 2010) and PGs (Vafopoulou and Steel, 1998) that together form a multi-oscillator circadian timing system in the larval insect. Circadian organization is equally important in adult physiology, yet little is currently known of how it is achieved. The PGs are absent in adults (Wigglesworth, 1955) but ecdysteroids are still present, though generally in lower amounts than in larvae (Raikhel et al., 2005). The larval PGs remain the only known target of PTTH

(Rybczynski, 2009) and therefore PTTH is generally considered an exclusively larval hormone.

However, PTTH was originally purified from adult moth heads (Kataoka et al., 1987, 1991) and some more recent evidence suggests that PTTH is present in adult insects (McBrayer et al., 2007; Zhang and Denlinger, 2011). This laboratory has now shown that the brain of adult *Rhodnius* contains and releases a neuropeptide that is electrophoretically, immunologically, and biologically indistinguishable from larval PTTH (Chapter 2, Vafopoulou et al., 2012). Moreover, the content of PTTH in the adult brain was found to cycle with a daily rhythm throughout most of egg development and was complimented by a corresponding daily rhythm of *in vitro* PTTH release (Chapter 2, Vafopoulou et al., 2012). These findings argue that PTTH may have a function in adult physiology. Additionally, the cerebral circadian clock system has been elucidated in larval (Vafopoulou et al., 2010) and adult *Rhodnius* (Vafopoulou and Steel, 2012) and axons from the PTTH cells in the brain of both larvae and adults are closely associated with clock neurons (Vafopoulou et al., 2007). Therefore, the potential for clock control of PTTH is present in adults.

In the present paper we show that the clear daily rhythm of PTTH release by adult brains is endogenous and under circadian control. Additionally, we report that the light/dark transition successfully reinitiated rhythmic release of PTTH in animals rendered arrhythmic by prolonged exposure to continuous constant light, demonstrating that photic cues can modulate rhythmic PTTH release and supporting the conclusion that PTTH is regulated by a photosensitive clock in the brain. Furthermore, PTTH is

demonstrated to be present in adult hemolymph, in which its levels cycle with a circadian rhythm that parallels the rhythm of PTTH release by the brain. It is inferred that PTTH is released by the brain and generates the rhythm seen in the hemolymph and that PTTH acts as a functional neurohormone in the adult insect. These results support a role of PTTH in the adult circadian system, though its exact targets remain unknown.

2. Materials and Methods:

2.1 Animals:

Rhodnius prolixus Stål (Hemiptera) were reared in a 12 h light : 12 h dark regime (LD) at constant temperature ($28^{\circ} \pm 0.5^{\circ}\text{C}$) and humidity ($70\% \pm 5\%$). Feeding of a single blood meal triggers a cycle of egg development and thus synchronizes the experimental population; the day of feeding is referred to as day 0. Adult females that had completed one egg production cycle were used throughout. Brain complexes (i.e. brain including corpus allatum and corpus cardiacum) were excised 4 times a day at 1 h and 7 h after lights-off and at 1 h and 7 h after lights-on. Insects were transferred to either constant dark (DD) or constant light (LL) conditions as indicated and brain complexes were collected every 6 h starting 1 h after transfer. Insects that were in darkness remained so until immediately before dissection. Arrhythmic adult females were produced by maintaining insects in continuous LL for a minimum of 3 weeks prior to feeding a blood meal. Such treatment eliminates behavioural rhythms of activity and oviposition (personal observation) and abolishes the endogenous rhythms of ecdysteroids in the hemolymph and ovaries (Cardinal-Aucoin, M., unpublished results).

For PG donors, male fifth instars were reared at $28^{\circ} \pm 0.5^{\circ}\text{C}$ in continuous light (LL) for a minimum of 3 weeks to abolish the intrinsic rhythmicity of ecdysteroid synthesis by PGs (Vafopoulou and Steel, 1991, 1992, 1993). The day of feeding was designated day 0 and PGs were dissected from animals on day 7.

2.2 Dot blots, SDS-PAGE, and western blots:

The presence and identification of PTTH-immunoreactive material in the hemolymph was confirmed by SDS-PAGE and western blotting using standard protocols (Vafopoulou et al., 2012). Tissues were collected from insects on day 5 after a blood meal. For brain extract, brain complexes were collected during the mid-photophase and homogenized in *Rhodnius* saline (Lane et al., 1975). For incubations, brain complexes were removed during the scotophase and incubated in 25 μl *Rhodnius* saline for 4h. Hemolymph was collected during mid-scotophase from a cut tarsus. Brain extract homogenate, brain incubation media, and hemolymph were then heated to 100°C for 3 min, centrifuged at 10 000 g for 10 min, and the supernatants were fractionated using Amicon Ultra-0.5 ml (Ultracel-PL 10 kDa membrane) centrifugal tubes (Millipore, Billerica, MA, USA) as per the manufacturer's instructions. The retentates were separated by 10% SDS-PAGE (non-reducing conditions), transferred to PVDF membranes, and probed with a mouse monoclonal antibody for PTTH.

The rhythmicity of PTTH-immunoreactive material in the hemolymph was investigated by dot blot analysis using standard procedures as described by Vafopoulou and Steel (2002). 5 μl of hemolymph, collected as above, was blotted onto a nitrocellulose membrane and probed with the anti-PTTH. Densitometric analysis of dot blots was

performed using the Gel Analyzer of Image J. Five dot blots were analyzed per time point.

2.3 Antibodies:

The PTTH antibody was a kind gift from Dr. A. Mizoguchi (Nagoya University, Nagoya, Japan) and was prepared against a synthetic fragment corresponding to amino acids 1–15 at the N-terminal of *Bombyx* PTTH (see Mizoguchi et al., 1990). This antibody specifically recognizes *Rhodnius* PTTH in brain extracts and brain incubation media in both larvae (Vafopoulou and Steel, 2002) and adults (Chapter 2, Vafopoulou et al., 2012) as well as the PTTH neurons in both larval and adult brains (Vafopoulou et al., 2007). This antibody was used at 1:1000.

The secondary antibody for both dot blots and western blots was a horseradish peroxidase conjugated anti-mouse IgG (Sigma, Oakville, ON) used at 1:200. Immnoreactive peptides were revealed with 3,3-diaminobenzidine hydrochloride (Sigma, Oakville, ON) and hydrogen peroxide.

2.4 In vitro bioassay for PTTH activity:

The *in vitro* PTTH bioassay has been described in detail elsewhere (Vafopoulou and Steel, 1993, 1996a) and its validity for use with material derived from adult brains has been previously demonstrated (Chapter 2, Vafopoulou et al., 2012). Briefly, PTTH activity of brain complex incubation media was assessed by its ability to stimulate ecdysteroid synthesis *in vitro* by PGs from arrhythmic male fifth instar *Rhodnius* (Vafopoulou and Steel, 1993, 1996a). Brain complexes were excised under *Rhodnius* saline and each complex was washed thoroughly and incubated in a 25 µl standing drop

of saline for 4 h. Incubation media were heated to 100°C for 3 min and stored at -80°C until further use. Brain media were partially purified by ultrafiltration using Amicon Ultra-0.5 ml (Ultracel-PL 10 kDa membrane) centrifugal tubes (Millipore, Billerica, MA, USA). The retentate was reconstituted in *Rhodnius* saline for use in the PG bioassay. The rate of ecdysteroid synthesis of each member of a pair of PGs is highly similar (Vafopoulou and Steel, 1989) and therefore one of each pair was incubated for 4 h with brain incubation medium while the contralateral PG provided a control and was incubated for 4 h in saline alone.

Ecdysteroids released into the incubation medium were then quantified by radioimmunoassay (RIA; see Section 2.5). The PTH activity of test samples was calculated as the difference in amount of synthesis (ng of 20-hydroxyecdysone (20E) equivalents/4 h) between treated and control members of each PG pair and was expressed as mean difference \pm SEM for a group of pairs. The paired sample *t*-test (two-tailed) was used to compare the differences in ecdysteroid synthesis in a group of pairs and the resulting *t* value was plotted as a Stimulation Index (SI), which reveals the level of significance of the mean differences (Vafopoulou et al., 1996a).

2.5 Ecdysteroid RIA:

The ecdysteroid RIA was performed as previously described (Steel et al., 1982; Vafopoulou and Steel, 1989) using the H-21-B antiserum (Horn et al. 1976), a kind gift from Dr. Ernest S. Chang (University of California, Davis). This antiserum is highly specific to ecdysteroids and has a greater binding affinity for 20-hydroxyecdysone (20E) than ecdysone (E; Gilbert et al., 1977). E and 20E are the main ecdysteroids in the

hemolymph of larval (Steel et al., 1982) and adult (Chapter 4, Cardinal-Aucoin et al., 2013) *Rhodnius*. The labeled ligand was α -[23,24-³H(N)]ecdysone (sp. act. 83.2 Ci/mmol) (New England Nuclear, Boston, MA). 20E (Sigma, Oakville, ON) was used as the standard and the results are therefore expressed as ng 20E equivalents.

3. Results:

3.1 PTTH biological activity persists in constant conditions:

When LD entrained animals were transferred to aperiodic conditions the daily rhythm of PTTH activity of brain incubation media continued for at least 3 cycles in constant conditions (Fig. 9). Brain incubation media were maximally stimulatory during the subjective scotophase (roughly 4 times photophase values) in both DD (Fig. 9A) and LL (Fig. 9B). These scotophase peaks correspond in every case with significant SI values (Fig. 9C and D). A slight damping of the amplitude is observed by the third day in LL (Fig. 9C), though the SI demonstrates that the rhythm remains significant (Fig. 9D). Basal release represents the minute amount of material released by brains of unfed insects; this material is never significantly stimulatory to PGs and results from minor mechanical damage to the brain sustained during dissection (Vafopoulou et al., 2012). PTTH release remained above baseline throughout the period of sampling (Fig. 9A and B), though photophase brain incubation media (Fig. 9C and D) never produced significant stimulation of PGs.

The free running period of the rhythmic changes in PTTH activity was unaltered when insects were transferred to DD at 24°C (data not shown), indicating that this rhythm is temperature compensated. Together, these results demonstrate that the previously

Figure 9: Rhythmic PTTH activity of brain incubation media in aperiodic conditions.

Entrained (LD) animals were transferred to DD (A and C) or LL (B and D) at the end of day 6 after a blood meal (arrow). Brain complexes were incubated in saline for 4h and the PTTH activity of sample media was evaluated by comparison of ecdysteroid synthesis by PTTH-stimulated PGs with their contralateral untreated controls (see Section 2.4). The difference in amount of synthesis (ng 20E eqts) between treated and control members of each PG pair was calculated and expressed as mean difference \pm SEM for a group of 5 pairs (A and B). These differences in synthesis by a group of pairs were compared using the paired sample *t*-test (two-tailed), and the resulting *t* value was plotted as a Stimulation Index (SI) (Vafopoulou et al. 1996). SI reveals the level of significance of the stimulation calculated in A and B. Stimulation above the horizontal line ($p = 0.05$) is significant. Dark bars indicate darkness and white bars indicate light.

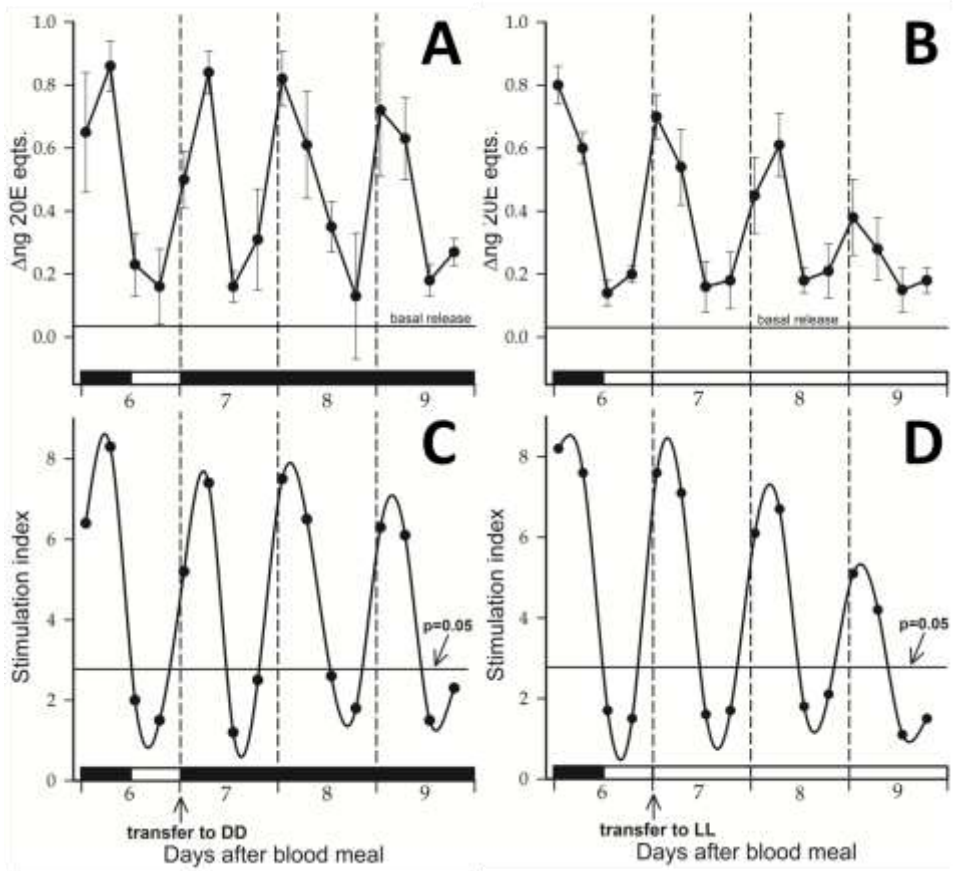

described daily rhythm of PTTH activity of brain incubation media (Vafopoulou et al., 2012) fulfill the requirements of a true circadian rhythm and are consequently regulated endogenously by the circadian timing system.

3.2 Induction of PTTH rhythmicity:

Brain incubation media from animals kept in LL for at least 3 weeks prior to a blood meal were unable to significantly stimulate PGs (Fig. 10A). In fact, PTTH activity was undetectable from such media at any time examined (Fig. 10A), as confirmed by the SI (Fig. 10B), i.e. PTTH release has ceased completely in these insects. Transfer of these arrhythmic animals from LL to DD reinitiated the large daily variations in PTTH activity of incubation media observed above (Fig. 11). Peaks of PTTH activity occurred each subjective photophase (Fig. 11A) and were mirrored by highly significant SI values (Fig. 11B). Therefore, the light to dark transition successfully induced rhythmic release of PTTH activity in previously arrhythmic animals, demonstrating that the circadian rhythm of PTTH in adults is affected by photic cues.

3.3 Hemolymph SDS-PAGE, western blots, and dot blots:

Probing of western blots with the PTTH antibody revealed an immunoreactive band at around 68 kDa present in brain extract, brain incubation media, and hemolymph (Fig. 12A). This band represents the native *Rhodnius* PTTH peptide that is released by the brain *in vitro* (Vafopoulou and Steel, 2002; Vafopoulou et al., 2012) and is seen to correspond with release into the hemolymph *in vivo*. Two additional immunoreactive bands at around 48 and 32 kDa were observed in brain extract and are considered to represent breakdown products of the larger 68 kDa peptide (Vafopoulou et al., 2002;

Figure 10: Absence of PTTH activity in brain incubation media from insects kept in LL 3 weeks prior to a blood meal on day 0. PTTH activity is expressed in two complementary ways (see Section 2.4). 1) The ability of incubation media to increase ecdysteroid synthesis by arrhythmic larval PGs was determined by comparing ecdysteroid synthesis by an experimental PG with its contralateral member of the pair and was expressed as the mean difference \pm SEM of 5 PG pairs (A). 2) The differences from 1 were compared using the paired t-test (two tailed) and plotted as a stimulation index (B), indicating the significance of the stimulation from 1. Tissues were dissected at 6h intervals. Points represent mean \pm SEM. Basal release (horizontal black line) represents material released by minor mechanical damage incurred during dissection. Hatched bars represent subjective scotophase for LL insects and actual scotophase for control LD insects.

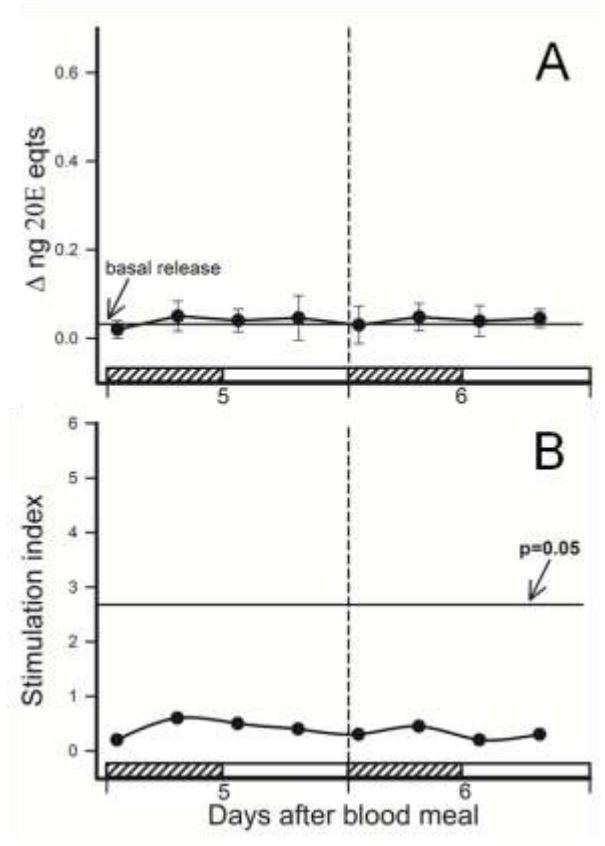

Figure 11: Rhythm of PTTH activity of brain incubation media is reinitiated by transfer of arrhythmic adult females from constant light (LL) to constant dark (DD). Animals were kept 3 weeks in LL prior to feeding to abolish their intrinsic hormone rhythms. LL animals were transferred to DD at the end of day 5 (arrow). Brains were incubated in saline for 4h and the PTTH activity of sample media was evaluated by comparison of ecdysteroid synthesis by PTTH-stimulated PGs with their contralateral untreated controls (see Section 2.4). The difference in amount of synthesis (ng 20E eqts) between treated and control members of each PG pair was calculated and expressed as mean difference \pm SEM for a group of 5 pairs. These differences in synthesis in a group of pairs were compared using the paired sample *t*-test (two-tailed), and the resulting *t* value was plotted as a Stimulation Index (SI) (Vafopoulou et al. 1996). SI reveals the level of significance of the stimulation of the mean differences calculated. White bars indicate light and black bars indicate darkness. Note that PTTH release is promptly induced by transfer to DD and this release occurs rhythmically with significant peaks during each subjective photophase.

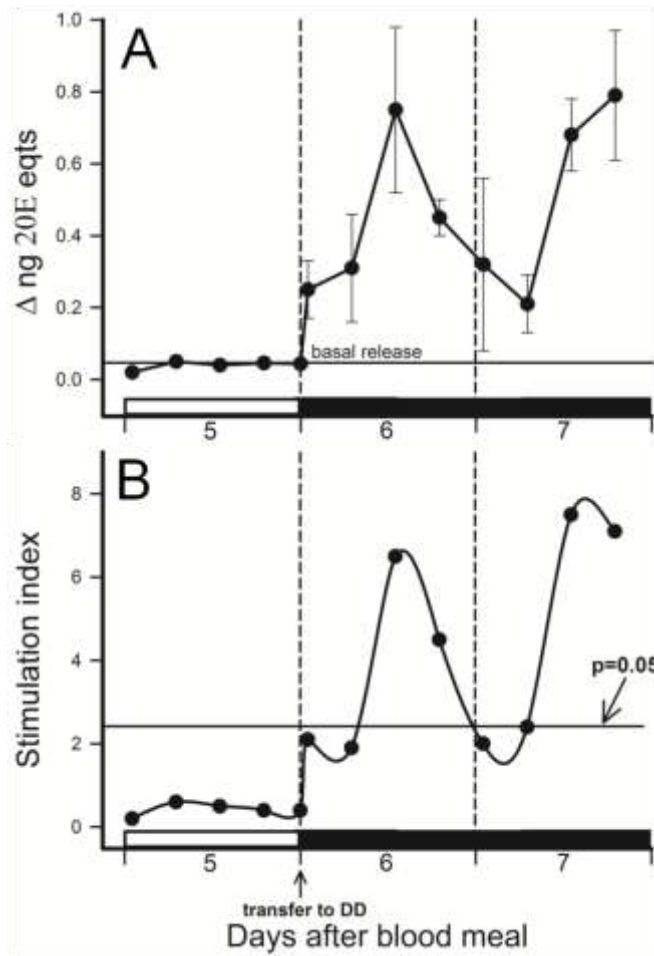
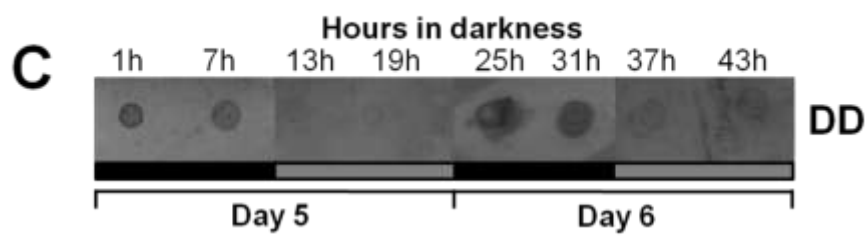
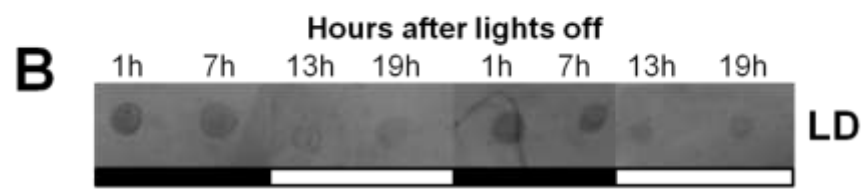
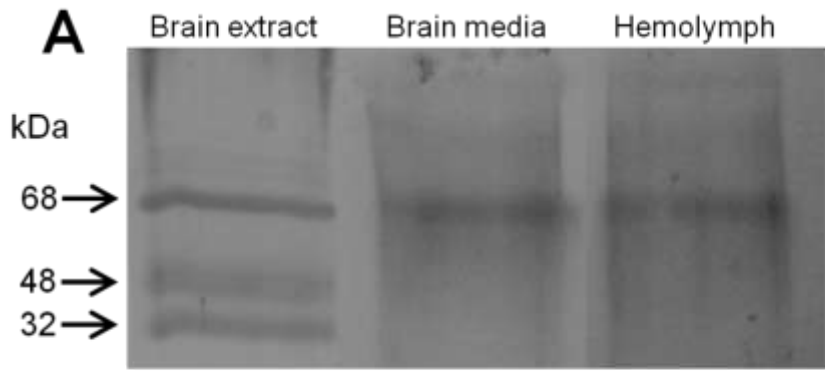

Figure 12: PTTH in hemolymph. SDS-PAGE (non-reducing conditions) and western blot analysis were carried out using tissues collected from animals day 5 after a blood meal (A): extract from 15 mid-photophase brain complexes, incubation media from 15 mid-scotophase brain complexes, and pooled mid-scotophase hemolymph from 15 animals. Dot blots were performed on hemolymph collected days 5 and 6 after a blood meal from entrained LD animals (B) and animals transferred to DD at the end of day 4 (C). Each dot represents 5 μ L of hemolymph. Material in A-C was probed using an antiserum against PTTH (see Section 2.3). White bars indicate light, black bars indicate darkness, and grey bars indicate subjective photophase.



Vafopoulou et al., 2012). These results are consistent with previous findings from both larvae (Vafopoulou and Steel, 2002) and adults (Vafopoulou et al., 2012) and demonstrate that material that is electrophoretically and immunologically identical to PTTH is present in hemolymph of adult insects.

Dot blots of hemolymph from LD animals revealed a clear daily rhythm of PTTH-immunoreactivity (Fig. 12B). Weak staining is observed during the photophase but during the scotophase the intensity of staining increased 6-fold, paralleling the scotophase release of PTTH by brains (Vafopoulou et al., 2012). The daily rhythm of PTTH-immunoreactivity in the hemolymph persisted in DD for at least 2 cycles, indicating that this rhythm is under circadian control. This agrees with the results reported above for PTTH biological activity of incubation media (Section 3.1). It is inferred that PTTH is released rhythmically by the brain and generates the rhythm observed in the hemolymph.

4. Discussion

We have previously demonstrated that during the period of egg development in adult *Rhodnius* the release of PTTH *in vitro* occurs with a clear daily rhythm (Chapter 2, Vafopoulou et al., 2012). Here we report that the daily rhythm of PTTH release persists in aperiodic conditions (both DD and LL) with a free running period of about 24h that is temperature compensated. Therefore, it fulfills the criteria of a bona fide circadian rhythm, indicating that PTTH is under circadian control in adult *Rhodnius*. A circadian rhythm of PTTH release has been reported in the larval insect (Vafopoulou and Steel, 1996b) that is regulated by a circadian clock in the brain (Vafopoulou et al., 2007). The complex neuroanatomy of the *Rhodnius* brain clock has been described in detail for both

larvae (Vafopoulou et al., 2010) and adults (Vafopoulou and Steel, 2012). Intimate associations between clock cells and PTTH cells exist in the larval brain and persist in adult *Rhodnius* (Vafopoulou et al., 2007) and therefore the neuroanatomical substrate for direct control of rhythmic PTTH release by the brain clock exists (Vafopoulou et al., 2007; Vafopoulou et al., 2010; Vafopoulou and Steel, 2012). This direct regulation of PTTH by the brain clock emphasizes the importance of rhythmic PTTH release by the brain, even in the adult insect. Sauman and Reppert (1996) described clock cells, in which the canonical clock proteins period (PER) and timeless (TIM) were shown to cycle, adjacent to the PTTH cells in *Antheraea*. Závodská et al. (2003) more recently reported that PTTH-positive cells in a variety of insect species from a range of orders tended to lie in close proximity to PER-positive cells. Therefore, regulation of PTTH by a brain clock appears to represent a wide spread and important phenomenon. However, the clear demonstration that identified clock cells regulate a circadian rhythm of PTTH release has only been made in *Rhodnius*.

Light cycles play an important role in the entrainment of circadian rhythms to the external environment. Earlier work suggested the existence of a photosensitive clock involved in the photoperiodic control of PTTH in moth pupae (Williams and Adkisson, 1964; Bowen et al., 1984) and is supported by results from larval *Rhodnius* (Vafopoulou and Steel, 2001). In order to examine the effect of photic cues on PTTH release in adult *Rhodnius*, animals were first rendered arrhythmic by exposure to continuous LL, which is known to disrupt circadian rhythms (Daan and Pittendrigh, 1976; discussed in Johnson et al., 2004). In larval *Rhodnius* chronic exposure to LL causes behavioural and hormonal

arrhythmicity (Ampleford and Steel, 1982; Vafopoulou and Steel, 1991, 2001) and in adults it eliminates the rhythms of activity and oviposition (personal observations) and abolishes the endogenous rhythms of ecdysteroids in hemolymph and ovaries (Cardinal-Aucoin, M., unpublished results). Here we found that exposure to LL led to the complete cessation of PTTH release by such arrhythmic animals. The transfer of such arrhythmic insects from LL to DD induced the rapid release of PTTH and reinitiated the circadian rhythm of PTTH release described above. In adult *Rhodnius*, neural pathways have been described leading from the compound eyes and ocelli to the lateral clock neurons (LNs) located at the base of the optic lobes (Vafopoulou and Steel, 2012) that are likely involved in the photic input pathway to the brain clock. Thus, in adult *Rhodnius* PTTH release is influenced by photic cues that are likely received by the LNs and communicated directly to the PTTH neurosecretory cells.

In both larvae and adults, PTTH release was immediately induced following transfer to DD, though several hours were required before significant release was achieved. Transfer of arrhythmic insects to DD also induced circadian rhythmic synthesis of ecdysteroids by the larval PGs *in vitro* (Vafopoulou and Steel, 1998) and *in vivo* (Vafopoulou and Steel, 2001). Therefore, the light/dark transition (as opposed to the dark/light transition) appears to act to induce expression of the clock and may therefore represent a re-synchronizing or entraining signal to the clocks in the brain and in the PGs. It has recently been shown that the expression (Vafopoulou and Steel, 2014) and cycling (Rapp, N., unpublished results) of the clock protein PER is immediately induced by transferring arrhythmic LL PGs from light to dark *in vitro* and that this coincides with the

previously reported rapid induction of rhythmic ecdysteroid release *in vitro* (Vafopoulou and Steel, 1998). The effect of photic cues on the brain clock has not been studied.

PTTH is a critical component of the larval circadian system (reviewed in Steel and Vafopoulou, 2006). In larvae, PTTH is released rhythmically into the hemolymph (Vafopoulou and Steel, 1996a) and acts on the larval PGs to stimulate and entrain rhythmic ecdysteroid synthesis (Pelc and Steel, 1997; Vafopoulou and Steel, 2001). In *Rhodnius*, the PGs disintegrate soon after ecdysis to the adult (Wigglesworth, 1955) and are therefore absent in the adult insect. This fact, the absence of the only known target of PTTH in the adult, would seem to render the release of this peptide into the adult hemolymph *in vivo* unnecessary. However, we report that PTTH was present in hemolymph of adult *Rhodnius*. A peptide that co-migrated with PTTH released by brains *in vitro* was identified in the hemolymph by western analysis. Additionally, dot blots with anti-PTTH revealed that the amount of PTTH in the hemolymph cycled with a daily rhythm that paralleled that of PTTH release by the brain. A similar daily rhythm of PTTH in larval hemolymph has been reported (Vafopoulou and Steel, 1996a). The rhythm of PTTH in hemolymph, as revealed by dot blots, continued in DD. Taken together these results demonstrate that PTTH is present and cycles with a circadian rhythm in adult hemolymph.

PTTH is often assumed to be a strictly larval hormone, though it was originally purified from the heads of adult *Bombyx mori* (Kataoka et al., 1987, 1991). More recently, PTTH mRNA has been reported in the brains of *Drosophila melanogaster* (McBrayer et al., 2007) and *Culex pipiens* (Zhang and Denlinger, 2011). PTTH peptide

has only been demonstrated in adult *Rhodnius* (Chapter 2, Vafopoulou et al., 2012) and this is the first report of PTTH in the hemolymph of any adult insect. It is inferred that the rhythm of PTTH release *in vitro* corresponds to release of PTTH into the hemolymph *in vivo*. It is proposed that photosensitive clocks in the brain regulate rhythmic PTTH release and generate the rhythm seen in the hemolymph. It is therefore suggested that PTTH acts as a functional neurohormone in adult *Rhodnius* and may be involved in the adult circadian system.

The only known function of PTTH is the ecdysteroidogenic stimulation of larval PGs. Nevertheless, the presence of PTTH in adults, its release as a neurohormone into the hemolymph, and its regulation by the circadian system argue against the long held notion of PTTH as a strictly larval hormone and support the contention that PTTH remains biologically functional in adults. As previously noted, there are no known targets of PTTH in adult insects. We previously noted that the rhythmic release of PTTH in adult *Rhodnius* coincides with the period of egg development and that PTTH may therefore be involved in processes related to oogenesis (Chapter 2, Vafopoulou et al., 2012). In fact, the end result of egg development, namely oviposition, is under circadian control (Ampleford and Davey, 1989), implying that the physiological and biochemical processes involved are likely also controlled by the circadian system. We have recently reported a circadian rhythm of the hemolymph ecdysteroid titer that is generated by the release of ecdysteroids by the ovaries during the same period (Chapter 4, Cardinal-Aucoin et al. 2013). These rhythms of ecdysteroids are synchronous with the rhythmic release of PTTH. The *Drosophila* PTTH receptor, Torso, was recently identified (Rewitz et al.,

2009) and its mRNA expression was reported in several adult tissues, including ovaries, which are known to be ecdysteroidogenic in *Drosophila* (Rubenstein et al., 1982). Ovarian ecdysteroidogenesis has been documented in several insect species (e.g. Hagedorn et al., 1975; Warren et al., 1996). PTTH acts as an ecdysteroidogenic neuropeptide in larvae and may do the same in adults. Considering the circadian regulation of both PTTH and ecdysteroids in both larvae and adults it is tempting to speculate that these hormones maintain a similar functional relationship within the circadian system in adults as they do in larvae.

Other ecdysteroidogenic peptides have been documented in adult insects such as the insulin-like peptides (ILPs; Manière et al., 2004) and ovary ecdysteroidogenic hormone (Brown et al., 1998). The peptides bombyxin, an ILP, and testis ecdysiotropin (TE) have both been identified in brain neurosecretory cells of adult *Rhodnius* and were shown to be under circadian control by the brain clock (Vafopoulou and Steel, 2012). ILPs in insects are multifunctional peptides that can act as hormones, neurotransmitters, and growth factors and have been implicated in the regulation of metabolism, reproduction, and longevity in adult insects (reviewed by Wu and Brown, 2006). ILPs and the insulin signaling pathway have been implicated in the control of reproduction in several insect species (for review see Claeys et al., 2002; Garofalo, 2002) and in a few cases have been specifically shown to regulate ovarian ecdysteroids (Graf et al., 1997; Riehle and Brown, 1999; Tu et al. 2002; Manière et al., 2004). The ILP receptor gene is mainly expressed in adult ovaries, particularly in the follicle cells (Fullbright et al., 1997; Graf et al., 1997; Helbling and Graf 1998; Riehle and Brown, 2002) which are considered

the source of ovarian ecdysteroids (Goltzené et al., 1978; Chavez et al., 2000). Therefore, ILPs may function in concert with PTTH and ecdysteroids in the regulation of egg development and the generation of temporal order in adult physiology.

CHAPTER FOUR
CIRCADIAN REGULATION OF HEMOLYMPH AND OVARIAN
ECDYSTEROIDS DURING EGG DEVELOPMENT IN THE INSECT
RHODNIUS PROLIXUS (HEMIPTERA)

Chapter Four has been published previously in *Comparative Biochemistry and Physiology - Part A: Molecular and Integrative Physiology* as:

CARDINAL-AUCOIN, M., RAPP, N., STEEL, C.G.H., 2013.

Circadian regulation of hemolymph and ovarian ecdysteroids during egg development in the insect *Rhodnius prolixus* (Hemiptera). *Comp. Biochem. Physiol. A* 166, 503-509.

M.C.-A. performed all experiments, analyzed data, and wrote the manuscript.

N.R. helped collect tissues for circadian studies and performed the RIA for those samples.

C.G.H.S. secured funding for the project and helped write the manuscript.

Prefix:

Ecdysteroids, classically studied as the molting hormones of insects, occur at lower levels in the adult stage, but their source and significance in adult physiology is debated. In *Rhodnius*, a blood meal initiates a cycle of egg development and ecdysteroids appeared in the hemolymph within 1-2 hours of feeding. Systematic changes in hemolymph ecdysteroid titer then occurred during egg development. There was a clear circadian rhythm in the hemolymph ecdysteroid titer throughout egg development. This is the first report of an ecdysteroid rhythm in any adult female insect. Of various tissues examined *in vitro*, only ovaries released ecdysteroids. The amounts released were adequate to account for observed hemolymph ecdysteroid titers. Therefore, ovaries are the primary, perhaps sole, source of hemolymph ecdysteroids. Ovaries *in vitro* showed a circadian rhythm of changes in ecdysteroid content and release that was in synchrony with the hemolymph ecdysteroid rhythm, indicating that ovarian ecdysteroid release drives the rhythm seen in the hemolymph. Potential regulation of ovarian ecdysteroids is discussed in relation to the known rhythms in prothoracicotropic hormone and insulin-like peptides that occur during egg development. The prospect of circadian regulation of egg development itself by hormones and/or an ovarian clock is also discussed.

Keywords: circadian clock, ecdysteroids, endocrine rhythm, feeding, insulin-like peptides, oogenesis, prothoracicotropic hormone, reproduction.

1. Introduction

Endocrine rhythms have been described in vertebrates (reviewed by Haus, 2007; Hastings et al., 2007) and insects (reviewed by Vafopoulou and Steel, 2009) but their significance has only more recently been appreciated (Steel and Vafopoulou, 2006; Vafopoulou and Steel, 2009). It is now recognized that endocrine rhythms distribute timing information to diverse target tissues throughout animals and consequently act as essential ‘messengers of time’ that coordinate temporal order throughout animals.

In insects, ecdysteroids are critical developmental hormones of larval insects that are central to the regulation of molting and metamorphosis. They have been shown by this laboratory to be important regulators of larval circadian organization and distributors of circadian timing information (reviewed in Steel and Vafopoulou, 2006). It is now well established that ecdysteroids are also present in adult insects, though generally in lower concentrations than in larvae (Raikhel et al., 2005; Brown et al., 2009). The prothoracic glands (PGs) are the major source of these ecdysteroids in larvae, but PGs are absent from adult insects, in which various alternative sites of ecdysteroid production have been described, including the gonads, epidermis, and oenocytes (Delbecque et al., 1999; Brown, 2009). In adult females, the ovaries of many insect species, from a range of orders, have been identified as a major source of ecdysteroids (Brown et al., 2009).

Ecdysteroids have been detected in the hemolymph of adult *Rhodnius* (Ruegg et al., 1981), but their relation to egg development has not been studied in this species. Many reproduction-related phenomena in insects have been demonstrated to be rhythmic and under circadian control (Vafopoulou and Steel, 2009). In *Rhodnius*, there is a

circadian rhythm of oviposition (Ampleford and Davey, 1989), which suggests circadian involvement in the physiological regulatory mechanisms that control egg development, potentially including reproductive hormones. The possibility of rhythmicity of ecdysteroid levels in adult female insects and their potential involvement in the adult circadian system have never been investigated. Indeed, there have been few studies of the physiological mechanisms by which circadian organization is generated in adult insects.

The blood feeding insect *Rhodnius prolixus*, used in the pioneering studies of Wigglesworth, is well-suited to these types of investigations. In adult females, a blood meal initiates a cycle of egg development (Buxton, 1930; Friend et al., 1965; Pratt and Davey, 1972), enabling the precise experimental synchronization of a population of animals. We have employed *in vitro* incubation techniques and ecdysteroid radioimmunoassay (RIA) to elucidate the relation between ecdysteroids and egg development in adult *Rhodnius* and to begin to explore the circadian organization of the adult insect. We report that a blood meal triggers release of ecdysteroids and the resulting hemolymph ecdysteroid titer exhibits a clear circadian rhythm throughout the period of egg development. Ovaries *in vitro* released ecdysteroids rhythmically and the amounts released were adequate to account for the levels of ecdysteroids in the hemolymph, indicating that the circadian rhythm seen in the hemolymph is generated by circadian control of release of ecdysteroids from the ovaries. The findings are discussed in relation to the emerging similarities in the hormonal regulation of reproduction and development and the role of endocrine rhythms in generating internal temporal order.

2. Materials and Methods

2.1 Animals and tissue collection

Adult female *Rhodnius prolixus* Stål (Hemiptera) were reared in a 12 h light : 12 h dark (LD) regime at $28\pm 0.5^{\circ}\text{C}$ and constant humidity. Feeding of a single blood meal initiates a cycle of egg development and thus synchronizes a population of animals; the day of feeding is referred to as day 0. Females that had completed one egg production cycle were used throughout. For the profiles of ecdysteroids during egg development, hemolymph and ovaries were collected once a day at mid-scotophase. For daily rhythm studies, tissues were collected every six hours (at 1 h and 7 h after lights-off and at 1 h and 7 h after lights-on). For circadian studies, insects were transferred from LD on day 7 after feeding to either constant dark (DD) or constant light (LL) (as indicated in Section 3.) and hemolymph and ovaries were collected every 6 hours as before for the following 3 days.

Hemolymph was collected from a cut leg and stored in methanol at -20°C until needed. Pairs of ovaries were excised, washed thoroughly in three changes of *Rhodnius* saline (Lane et al., 1975) and incubated *in vitro* in 200 μl *Rhodnius* saline for 4h. Incubation of photophase ovaries was performed in light while incubation of scotophase ovaries was carried out in the dark. Following incubation, media were removed and stored in methanol at -20°C . Animals or tissues from scotophase or DD were kept in the dark until immediately before tissue collection. A minimum of 5 insects was sampled per time point.

2.2. Extraction of ecdysteroids from ovaries

The high concentration of lipids and glycoproteins in the ovary required the extraction of ecdysteroids by removing the lipid fraction of a methanol:hexane partition (3:7:10, water:methanol:hexane). Ovaries were homogenized in 125 μ l water in a 1.5ml graduated microtube. 525 μ l methanol was added and the mixture was centrifuged at 15000g for 5 min. The supernatant was removed and saved. The pellet was resuspended in 100 μ l water and centrifuged. Supernatants were pooled, 750 μ l hexane was added, and the mixture was centrifuged again. The upper (lipid) fraction was removed and the aqueous fraction, containing the ecdysteroids, was stored at -20°C until assayed by RIA. The procedure was standardized by removing a constant volume (0.5ml) of the aqueous phase. The efficiency of this extraction procedure was determined as follows. Ovaries were removed from two animals during the scotophase of day 6. One ovary from each animal was paired with one ovary from the other. One of the pairs was subjected to the extraction protocol above. A known amount of pure 20-hydroxyecysone (20E) was added to the second pair as an internal standard and then processed through the same extraction procedure. The efficiency of recovery of the added 20E could then be calculated by comparison of the ecdysteroid content of the two pairs of ovaries. Ten matched pairs of ovaries were processed in this way, from which the mean extraction efficiency was calculated to be 72-77%. The data presented have been corrected for this mean loss of ecdysteroids of 25%.

2.3. Ecdysteroid quantification and determination

Ecdysteroids were quantified by RIA as previously described (Steel et al., 1982; Vafopoulou and Steel, 1989). α -[23,24-³H(N)]ecdysone (sp. act. 83.2 Ci/mmol)

(PerkinElmer, Billerica, MA) was used as the labeled ligand. H-21B antiserum (Horn et al., 1976) was employed and was a kind gift from Dr. Ernest S. Chang (University of California, Davis). This antiserum has a greater binding affinity for 20E than ecdysone (E) (Horn et al., 1976) and conjugated ecdysteroids are not immunoreactive (Gilbert et al., 1977). E and 20E are the main ecdysteroids in hemolymph of *Rhodnius* larvae (Steel et al., 1982). The results are expressed as ng 20E equivalents since 20E (Sigma, St. Louis, MO) was used as the standard. Chemical analysis of the ecdysteroids from hemolymph and ovaries was carried out by reverse phase high pressure liquid chromatography (RP-HPLC) as previously described (Steel et al., 1982). Results were analyzed by Student's t-test and non-parametric analysis of variance (Kruskal and Wallis, 1952).

3. Results

3.1. Hemolymph ecdysteroid levels

The hemolymph of unfed adult female *Rhodnius* contained negligible ecdysteroids (Fig 10A). Within 2h of receiving a blood meal, ecdysteroids appeared in the hemolymph (Fig. 13A inset) and maintained a level of about 6 ng/ml for three days (Fig. 13A). On day 3, the titer abruptly increased by 4-5 fold to a steady level around 25 ng/ml that was maintained throughout the period of egg development until sampling ceased on day 10 (Fig. 13A). RP-HPLC revealed that E and 20E were the major ecdysteroids in hemolymph, as had been found in larvae (Steel et al., 1982).

3.2 Ovarian ecdysteroid content changes during egg development

Content and release *in vitro* of ecdysteroids was determined at various times after a blood meal for ovary, fat body, brain, midgut and abdominal epidermis. Only the ovary contained and released detectable ecdysteroids. Subsequent attention was therefore directed to the role of the ovary in ecdysteroid production.

The ecdysteroid content of ovaries was examined throughout the course of egg development. Ovaries from unfed insects contained negligible immunoreactive ecdysteroids (Fig. 13B), but promptly after receiving a blood meal, detectable levels of ecdysteroids appeared in the ovary (Fig. 13B). Between days 3-4, ovarian ecdysteroid content increased 4-5 fold to a level that was sustained for the duration of egg development. This pattern is closely similar to that seen in the hemolymph titer (compare Figs. 13A and 13B). There are two possible interpretations of this similarity; either a) the ovary passively absorbs hemolymph ecdysteroids and consequently contains the same concentration of immunoreactive ecdysteroids as does the hemolymph at any time or b) the ovary produces the ecdysteroids found in the hemolymph. Table I analyzes the likelihood of the first possibility on three different days after feeding. Assuming ovaries have a density close to 1.0, the total amount of immunoreactive ecdysteroids that would be expected to be found in a pair of ovaries was calculated from their weight, using the assumption that ovaries contained the same concentration of immunoreactive ecdysteroids as an equal volume of hemolymph. These values are compared with RIA determinations of ecdysteroid content of ovaries on each of these days. At all times, ovaries contained 7-8 times as much immunoreactive ecdysteroids as would be predicted from interpretation a) above (column 6 in Table I). Therefore, ovaries contain massively

Figure 13: Ecdysteroid levels in (A) hemolymph, (B) ovaries and (C) incubation media from pairs of ovaries during egg development after a blood meal at day 0 (dashed vertical line). Points represent mean \pm SEM of 5 animals. In A, solid bar represents period of vitellogenesis as defined by Huebner and Anderson (1972) and white bar shows period of oviposition. Hatched ends of bars indicate range of onset and end of these events in a population. Inset is an enlarged view of ecdysteroid titer showing abrupt increase at 2h after a blood meal. Note synchronous changes in ecdysteroid levels in A, B and C.

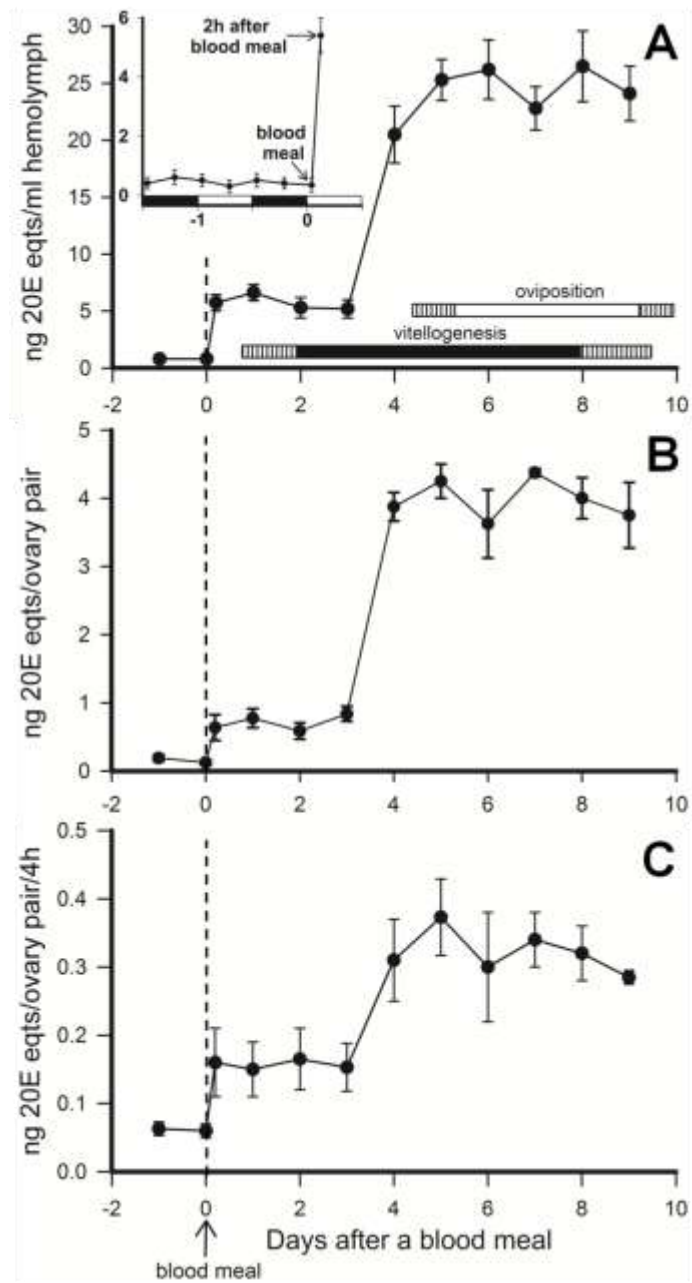

Table I
Ovaries contain high levels of ecdysteroids

Days after a blood meal	Mean wt. of ovary pair (mg \pm SE)	Mean hemolymph ecdysteroid titer (ng 20E eqts/ml \pm SE)	Expected ecdysteroid content of ovary pair (ng 20E \pm SE)	Actual ecdysteroid content of ovary pair (ng 20E \pm SE)	Ratio of actual:expected ovary ecdysteroid
6	12.25 \pm 1.5	27.59 \pm 1.6	0.34 \pm 0.06	2.84 \pm 0.12	8.4
7	18.33 \pm 1.8	25.28 \pm 2.2	0.46 \pm 0.08	3.79 \pm 0.18	8.2
9	15.35 \pm 1.6	30.28 \pm 3.1	0.46 \pm 0.09	3.25 \pm 0.21	7.0

greater quantities of immunoreactive ecdysteroids than can be explained by their passive absorption from surrounding hemolymph. This finding is strongly suggestive of interpretation b) above. Consequently, we examined the production of ecdysteroids by ovaries and their contribution to the hemolymph ecdysteroid titer.

3.3. Pattern of release of ecdysteroids from ovaries during egg development

Pairs of ovaries were removed at various times during egg development, incubated for 4h *in vitro* and the amount of immunoreactive ecdysteroids in the medium determined at the end of incubation. Unfed insects neither contained (Fig. 13B) nor released (Fig. 13C) immunoreactive ecdysteroids. But ovaries from animals 2h after feeding showed an abrupt increase in the content of ecdysteroids (Fig. 13B) and also in their release into the medium (Fig. 13C), suggesting that ovarian ecdysteroids are promptly released into the hemolymph. This initial level of release was sustained until day 3, at which time a second increase occurred to a new plateau level (about 2.5 fold higher) that was sustained until at least day 9 (Fig. 13C). This elevated level of release *in vitro* is adequate to produce the elevated hemolymph ecdysteroid titer (Fig. 13A) seen during this time (see Section 4). The overall profile of release from ovaries *in vitro* closely parallels that of the hemolymph titer measured *in vivo*, consistent with the view that hemolymph ecdysteroids originate from the ovaries.

3.4. Daily rhythms in hemolymph and ovarian ecdysteroids

Analysis of the hemolymph ecdysteroid titer using four time points per day revealed that massive changes in titer occur within the course of each 24h period following feeding (Fig 11A). A clear daily rhythm in the hemolymph titer is revealed,

Figure 14: Entrained rhythms in ecdysteroid levels in (A) hemolymph, (B) ovaries and (C) incubations media of ovaries throughout egg development after a blood meal at day 0 (dashed vertical line). Tissues were dissected at 6h intervals. Note that the rhythm in the haemolymph closely parallels the rhythms of ovarian ecdysteroids and incubation media with daily peaks each scotophase and daily troughs each photophase. Points represent mean \pm SEM of 5 animals. Dark bars indicate scotophases and white bars indicate photophases

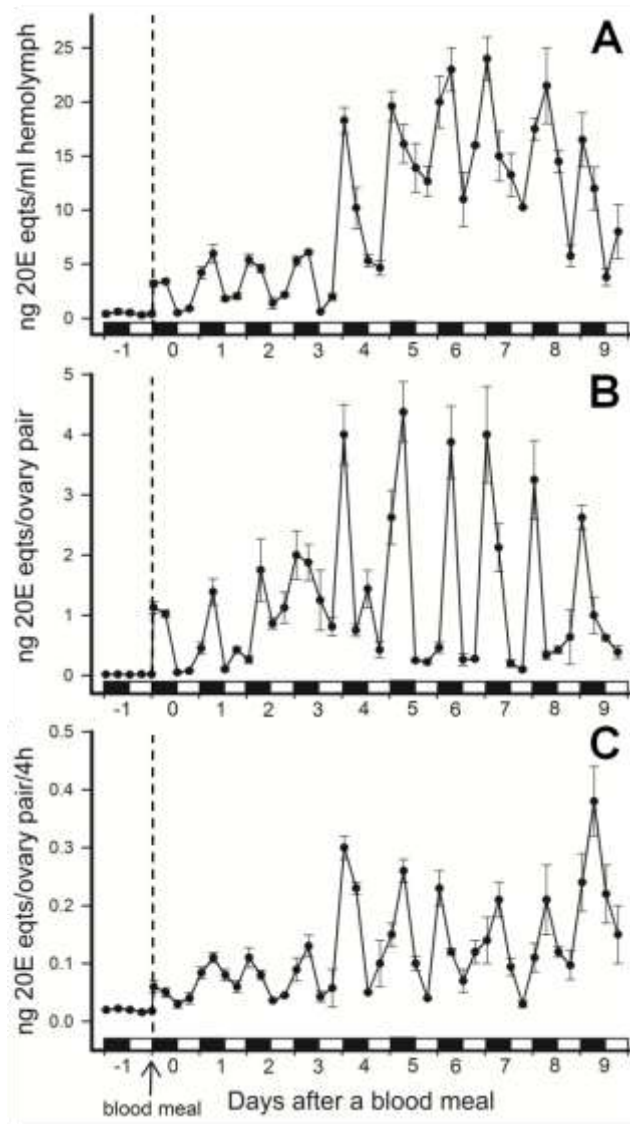

with peak values occurring during each scotophase and troughs each photophase ($p < 0.01$). Both the ovarian content of immunoreactive ecdysteroids (Fig. 14B) and the release *in vitro* (Fig. 14C) also show clear daily rhythms throughout the same time period, again with peaks in the scotophase and troughs in the photophase ($p < 0.01$). The abrupt increase at day 3-4 in ovarian content and release (Figs. 13B, C) is accompanied by equally abrupt increases in the amplitudes of the rhythms of both content (Fig. 14B) and release (Fig. 14C) of ovarian ecdysteroids. It should be noted that the photophase levels of both content and release remain low throughout egg development, showing that accumulation of immunoreactive ecdysteroids in the ovary does not occur.

3.5. Circadian regulation of ecdysteroids

The possibility that the above daily rhythms in ecdysteroids were under circadian control was examined by investigating their persistence in aperiodic environments (DD or LL). Fig. 15A shows that when day 7 animals are transferred to DD, a robust rhythm in hemolymph ecdysteroid titer persisted for at least three days, with a period length that was close to 24h. This finding strongly indicates that the ecdysteroid titer is under endogenous circadian control. When transferred to LL (Fig 15B), the ecdysteroid rhythm damped out after two cycles (see Section 4).

The ecdysteroid content of ovaries removed from animals which had been transferred on day 7 to either DD (Fig. 15C) or LL (Fig. 15D) was also examined. A robust rhythm in the content of immunoreactive ecdysteroids from ovaries continued in DD for at least three cycles (Fig. 15C), showing that ecdysteroid content is also under circadian control, but when transferred to LL, it damped out after two cycles (Fig 15D).

Figure 15: Free-running rhythms in hemolymph ecdysteroid titer (A, B) and levels of ovarian ecdysteroid content (C, D) under constant conditions. A, C, transfer to continuous dark (DD) at the end of photophase of day 6 after a blood meal. B, D, transfer to continuous light (LL) at the beginning of photophase of day 6. Dark bars indicate darkness and white bars indicate light. Vertical dashed lines depict subjective days in each of which the first half is subjective scotophase and the second half is subjective photophase. Note that both rhythms of ecdysteroid titer and ovarian ecdysteroids remain coupled and robust for 3 cycles in DD in A and C and the period length is close to 24h. Note that rhythms damp out after the second cycle in LL in B and D. Points represent the mean \pm SEM of at least 5 animals.

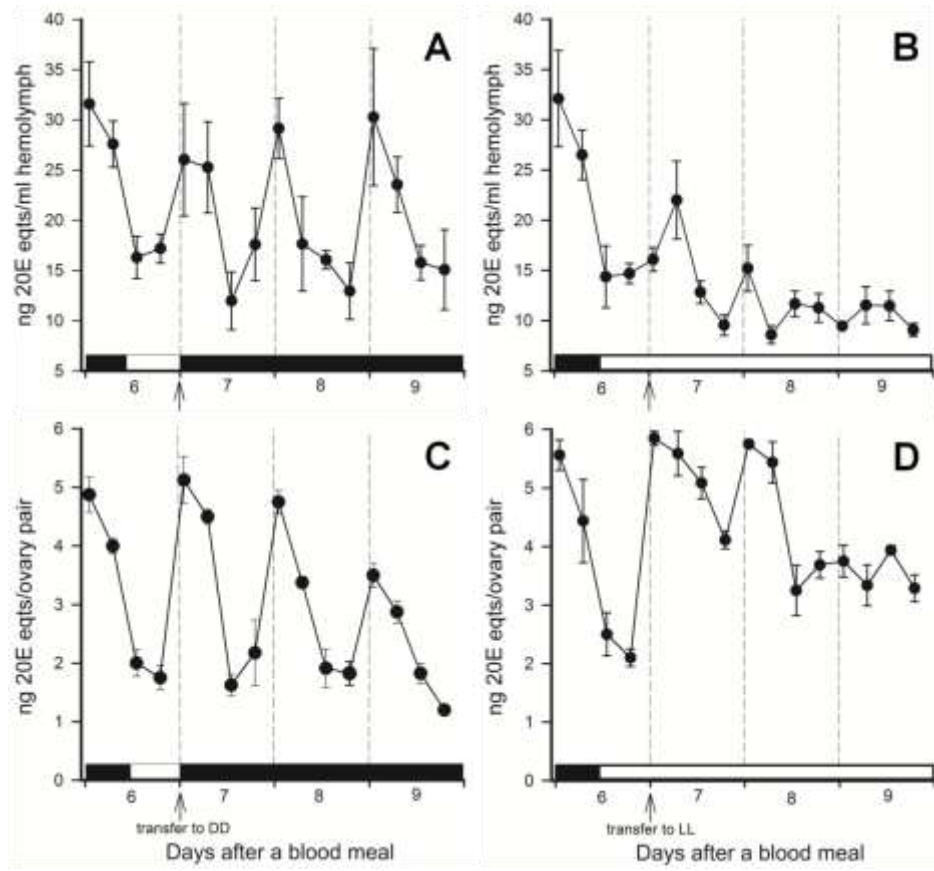

Thus, the ovarian content of immunoreactive ecdysteroids responded to transfer to DD or LL in a very similar fashion to the hemolymph ecdysteroid titer (see Section 4).

4. Discussion

4.1. Ecdysteroids in the hemolymph and ovaries

Ecdysteroids were first detected in adult insects in the 1970's (reviewed by Hagedorn, 1985) and their presence in adults is well established (Raikhel et al., 2005; Brown, 2009). Ecdysteroids have been found in all adult insect species in which they were sought. We detected ecdysteroids in both the hemolymph and ovaries of adult female *Rhodnius* throughout a cycle of egg development. Additionally, ovaries were found to release ecdysteroids during *in vitro* incubation. The only ecdysteroids detected were E and 20E, and 20E was the predominant hemolymph ecdysteroid. E and 20E are known to be the principle hemolymph ecdysteroids in larval *Rhodnius* (Steel et al., 1982) and several studies employing HPLC have found that E and 20E are the most common free ecdysteroids in the hemolymph of adults of other insect species (Bullière et al., 1979; Rubenstein et al., 1982; Zhu et al., 1983; Stay et al., 1984; Weaver et al., 1984; Wilps and Zöller, 1989; Hoffman et al., 1992; Pascual et al., 1992; Chen and Kelly, 1993). E and 20E were also the main ecdysteroids released by ovaries *in vitro* (Zhu et al., 1983; Stay et al., 1984; Wilps and Zoller, 1989).

The levels of hemolymph ecdysteroids changed systematically throughout the course of egg development. Ecdysteroids were not detectable in the hemolymph of unfed insects, but a blood meal resulted in the appearance of ecdysteroids in the hemolymph in 1-2h. A second large increase in ecdysteroid levels was observed 3-4 days after feeding,

and this high level was maintained throughout egg development, suggesting they may play a role in egg development in *Rhodnius*.

The potential source(s) of the hemolymph ecdysteroids were examined. Several ecdysteroidogenic tissues have been reported in adult insects, including the ovaries (Hagedorn et al., 1975; Lagueux et al., 1977; Feldlaufer et al., 1986), testes (Loeb et al., 1984; Vafopoulou and Steel, 2005; Polanska et al., 2009), and epidermis (Delbecq et al., 1990). Recently, Yamazaki et al. (2011) reported that both the brain and fat body of the honeybee released ecdysteroids *in vitro*. Therefore, ovaries, crop, fat body, epidermis, and brain, were assayed for ecdysteroid content and for their ability to release immunoreactive ecdysteroids during *in vitro* incubation. Only the ovaries contained and released detectable amounts of ecdysteroids.

On several days after feeding, we found that ovaries consistently contained a level of immunoreactive ecdysteroids that was 7-8-fold higher than they would if they contained only the same concentration of ecdysteroids as that found in the hemolymph i.e. immunoreactive ecdysteroids are concentrated within the ovary. We do not yet know whether ecdysteroids are synthesized *de novo* in the ovary or are produced by deconjugation of stored ecdysteroids. Both possibilities could be correct, since newly synthesized ecdysteroids could be partly released into the hemolymph and partly taken up by oocytes and then conjugated. This dual role of ovarian ecdysteroids fits closely with findings for other insects. Both free (Bitsch et al., 1979; Bullière et al., 1979; Zhu et al., 1983) and conjugated (Sall et al., 1983; Dinan et al., 1997; Tawfik et al., 1999; Sonobe and Yamada, 2004, reviewed by Swevers and Iatrou, 2009) ecdysteroids are present in

insect ovaries. Ovarian follicle cells have been found to synthesize ecdysteroids (Goltzené et al., 1978; Zhu et al., 1983) and express enzymes of the ecdysone biosynthetic pathway (Ono et al., 2006; Ito et al., 2008). It is believed that some of these ecdysteroids escape into the hemolymph and some are taken up by developing oocytes, in which they are conjugated and stored for later use in regulation of embryonic molts (Lagueux et al., 1979, 1981; Sall et al., 1983).

The systematic changes in the levels of immunoreactive ecdysteroids in the ovaries of *Rhodnius* are in tight synchrony with the changes in the hemolymph ecdysteroid titer, which further supports the conclusion that hemolymph ecdysteroids derive from the ovary in *Rhodnius*. Moreover, the following calculation indicates that the amount of ecdysteroids released by the ovaries *in vitro* appears sufficient to account for all the ecdysteroids in the hemolymph. The expressible hemolymph volume represents a fairly constant 45% of the total hemolymph volume in both larval (Maddrell and Gardiner, 1980) and adult *Rhodnius* (Gringorten and Friend, 1979), indicating that the hemolymph volume of adult females is about 25 μ l. The hemolymph ecdysteroid titer increases rapidly each scotophase by about 13ng/ml (Fig. 15A), which represents the addition of about 0.3ng ecdysteroids to the hemolymph of the animal. At this same time, one pair of ovaries *in vitro* releases about 0.25ng ecdysteroids, or 80% of the amount by which the hemolymph titer increases. Ovaries *in vitro* are unlikely to perform to their full *in vivo* capacity. We conclude that the release of ecdysteroids from the ovaries each night is adequate to account for the observed increases in the hemolymph titer. From these

several lines of evidence, we conclude that the ovaries are the primary, and perhaps only, source of ecdysteroids in adult female *Rhodnius*.

The ovarian content of immunoreactive ecdysteroids changes during egg development in a similar two step pattern to that described for the hemolymph titer. Immediately after feeding, both ecdysteroid content and release of ecdysteroids from ovaries *in vitro* increases abruptly. We suggest that newly produced ecdysteroids are rapidly released from the ovary into the hemolymph. An equally rapid onset of ecdysteroid synthesis following a blood meal in *Rhodnius* was seen in larval PGs (Steel et al., 1982; Vafopoulou and Steel, 1989). It remains possible that the unfed ovary contains non-immunoreactive ecdysteroid conjugates, which are deconjugated rapidly after feeding and released into the hemolymph.

4.2 Circadian regulation of hemolymph and ovarian ecdysteroids:

Circadian rhythmicity has not previously been reported in ecdysteroid levels in any adult female insect. We report that in *Rhodnius* a daily rhythm in the hemolymph ecdysteroid titer commences immediately after a blood meal and continues throughout the 10 days of sampling, when egg development occurs. Rhythmicity is seen in both the initial low levels of hemolymph ecdysteroids and the subsequent higher levels. The rhythm displays peaks each scotophase. The rhythm remains robust after transfer to DD for at least three cycles with a roughly 24h period length and therefore is under circadian control. When transferred to LL, the rhythm persists for about two cycles and then damps quite rapidly. Many circadian rhythms damp more rapidly in LL than in DD (discussed in Johnson et al., 2004). The characteristics of these ecdysteroid circadian rhythms are

extremely similar to those reported for the ecdysteroid rhythm in the fifth larval instar of *Rhodnius* (Ampleford and Steel, 1985), despite the much lower titers found here in adult females. A rhythm in hemolymph ecdysteroids was found in males of the moth, *Spodoptera littoralis*, two days after eclosion (Polanska et al., 2009), but their origin was unclear.

Ovaries incubated *in vitro* also released immunoreactive ecdysteroids with a daily rhythm. This rhythm also commenced immediately after a blood meal and continued throughout the 10 days of sampling. The increase in hemolymph ecdysteroid titer on days 3-4 is accompanied by an increase in amplitude of the daily rhythm of release from ovaries. A parallel daily rhythm in the ovarian content of immunoreactive ecdysteroids was also seen. All these rhythms (in hemolymph titer, ovarian release and content of ecdysteroids) occur in synchrony each day. Further, the rhythm of ovarian content of ecdysteroids was studied in DD and LL and was found to free-run more robustly in DD than in LL, with exactly similar characteristics to the hemolymph titer under the same conditions. Ovarian ecdysteroids are therefore also under circadian control. Since ovarian ecdysteroids appear to be the major, if not sole, contributor to the hemolymph titer, the findings above strongly suggest that circadian regulation of the hemolymph titer is achieved primarily through circadian control of synthesis and release of ecdysteroids by the ovaries. Ovaries produce immunoreactive ecdysteroids at night and these are released into the hemolymph before dawn each day, and possibly some are also converted to non-immunoreactive conjugates. The daily decreases in hemolymph ecdysteroid levels implies ecdysteroids can also be removed rapidly from the hemolymph. This mechanism

is probably also rhythmic, for reasons discussed for the larval ecdysteroid rhythm by Steel and Ampleford (1984). A role of circadian control mechanisms in insect egg development now seems likely, particularly as its end result, oviposition, is also under circadian control in *Rhodnius* (Ampleford and Davey, 1989).

Recently, we reported a daily rhythm of PTTH release from the brain of adult *Rhodnius* (Vafopoulou et al., 2012) that is induced by feeding and continues throughout egg development. This rhythm in PTTH release parallels the ovarian ecdysteroid rhythms described here, raising the prospect that the larval PTTH-ecdysteroid axis persists in adults. It was also recently shown that feeding elicits release of insulin-like peptides (ILPs) and testis ecdysiotropin (TE) from the brain of adult *Rhodnius*, and that the levels of these peptides vary with a strong daily rhythm that is controlled by the circadian clock in the brain (Vafopoulou and Steel, 2012). In several insect species, ILPs have been reported to regulate egg development (Richard et al., 2005; Brown, 2008) and ovarian steroidogenesis (Graf et al., 1997; Riehle and Brown, 1999; Manière et al., 2004). Therefore, ILPs may also be involved in the regulation of ovarian ecdysteroids in *Rhodnius*. In *Rhodnius* larvae, circadian control of ecdysteroids is achieved by coordinated action of a circadian clock in PGs (the site of synthesis of ecdysteroids in larvae) and circadian rhythms of release of PTTH and ILPs from the brain (reviewed by Steel and Vafopoulou, 2006). The data presented here invite comparison with this larval control system, with the ovaries replacing the PGs as the primary site of rhythmic ecdysteroid production in adults. These neuropeptide rhythms could either directly drive

ecdysteroid production by the ovaries, or they could act to entrain a clock in the ovaries, as was found to be the case with the larval PGs (Pelc and Steel, 1997).

The possible existence of an ovarian clock has been raised for both insects and vertebrates. mRNA of the canonical clock gene *period* (*per*) (Hardin, 1994) and PER protein (Saez and Young, 1988; Kotwica et al., 2009) have been detected in *Drosophila* ovarian follicle cells, the same cells that have been identified as the site of ecdysteroid synthesis in several insects (Hagedorn, 1985; Brown et al., 2009). In *Rhodnius* larvae, the rhythmic synthesis of ecdysteroids is controlled by a circadian clock in the PGs (Vafopoulou and Steel, 1998), a finding that invites comparison with their synthesis by ovaries in the adult stage. Cycling clock gene mRNA and proteins have been reported in rat ovary (Fahrenkrug et al., 2006; Karman and Tischkau, 2006; He et al., 2007) and chicken ovary (Tischkau et al., 2011). This vertebrate ovarian clock is located in ovarian follicle cells and is involved in regulating the timing of ovarian steroidogenesis and ovulation (review by Sellix and Menaker, 2012). Therefore, the existence of gonadal clocks may represent a more widespread evolutionarily conserved phenomenon than is currently appreciated.

CHAPTER FIVE GENERAL DISCUSSION

1. The significance of circadian rhythms

Life on earth has adapted to the periodic environment in which it has evolved; the most prominent periodic phenomenon being the 24 h cycle of light and dark produced by the rotation of the Earth on its axis. Circadian rhythms, the roughly 24 h rhythms in behaviour, physiology, and biochemistry are tuned to the 24 h light/dark cycle and occur universally in biological systems, from bacteria to humans. In addition to their ubiquity, the adaptive value of circadian rhythms is further supported by the observation of multiple independent evolutionary origins of circadian molecular clockwork in different taxa (Rosbash, 2009). Additionally, the vital importance of circadian rhythms is revealed by the detrimental consequences of disruption of the circadian system, such as reduced lifespan (Pittendrigh and Minis, 1972) in insects and increased incidence of disease, including depression, diabetes, and cancer, in shift workers and frequent sufferers of jet lag (Knuttson, 2003; Rudiger, 2004; Haus and Smolensky, 2013).

2. Circadian rhythms in adult insects

Insects have provided many valuable insights into circadian biology from basic principles of circadian rhythms to the molecular clockwork to the organization of cell and tissue clocks throughout the organism. At the molecular level, circadian rhythms are generated by interlocking transcriptional-translational feedback loops in which certain 'clock' genes are inhibited by their own protein products (Hardin, 2009). This molecular clockwork was first elucidated in *Drosophila* and is now known to involve around two dozen different genes, including the core clock genes *period* (*per*) and *timeless* (*tim*).

Remarkably, many of the genes involved in the molecular clockwork of animals and their organizational details are conserved from insects to mammals.

Adult insects exhibit a variety of circadian rhythms in behavior and physiology (Page, 1985; Vafopoulou and Steel, 2009). These circadian rhythms are now understood to be controlled by circadian clocks distributed throughout the insect (Giebultowicz, 1999; Tomioka et al., 2012), though the details of the organization and specific roles of the different clocks remain largely unknown. Circadian clocks in the brain have been described in a variety of adult insects (Homberg et al., 2003; Helfrich-Forster, 2005; Vafopoulou and Steel, 2009), though 'true clock cells', in which period (PER) and timeless (TIM) proteins have been shown to cycle, have been demonstrated only in *Drosophila* (Zerr et al., 1990; Hardin and Siwicki, 1995; Nitabach and Taghert, 2008) and *Rhodnius* (Vafopoulou et al., 2010; Vafopoulou and Steel, 2012a). Clocks in a number of peripheral cells and tissues, i.e. outside the central nervous system, have been described to varying extents. Among those peripheral clocks that have received comparatively more attention are antennae (Merlin et al., 2007, 2009), Malpighian tubules (Hege et al. 1997; Giebultowicz et al. 2000), and male reproductive tract (Bebas et al. 2001; Polanska et al., 2009). Although the regulation of behavioral rhythms by brain clocks has been well documented, the function of many peripheral clocks remains poorly studied or even completely unknown. Additionally, the integration of central and peripheral clocks is not well understood, though it certainly involves communication via nervous and hormonal pathways.

The adult stage is essentially adapted to reproduce. Reproduction is a critical part of the life cycle of organisms and involves the precise and timely coordination of multiple complex processes. It is expected that the circadian system plays a central role in the orchestration of reproductive events in insects. Circadian rhythms have been reported in insects for a number of processes related to reproduction, such as pheromone calling (Smith and Schal, 1991; Vafopoulou and Steel, 2009; Bloch et al., 2013a), mating (Sakai and Ishida, 2001; Fujii et al., 2007; Rymer et al., 2007), and oviposition (Ampleford and Davey, 1989; Manjunatha et al., 2008). However, the physiological regulatory mechanisms underlying such behaviors remain largely unknown.

Rhodnius prolixus is well suited to the study of the circadian physiology of reproduction for several reasons. Firstly, *Rhodnius* has been a model organism in insect physiology for decades, employed by Wigglesworth in his pioneering studies as early as the 1930's, and therefore a vast literature is available. Secondly, the circadian organization of larval development has been extensively studied in this insect (reviewed by Steel and Vafopoulou, 2006), providing useful concepts and principles that can guide the investigation of the adult system. Thirdly, the adult female remains in a state of reproductive developmental arrest until feeding on a blood meal triggers a cycle of oogenesis and oviposition. Therefore, the gonotrophic cycle of an entire population can be precisely synchronized experimentally by scheduled feeding. Finally, egg laying is known to be gated by the circadian system in this insect (Ampleford and Davey, 1989) and it is therefore expected that the physiological regulatory mechanisms involved in related processes, such as egg development, are also under clock control.

3. Circadian organization of the neuroendocrine system in adult female *Rhodnius*

3.1 The circadian clock in the brain

The anatomy of the circadian clock in the brain of *Rhodnius* has been described for both the larval (Vafoopoulou et al. 2010) and adult (Vafoopoulou and Steel, 2012a) stages. Most of the features of the larval brain clock are retained in the adult, though some new clock cells differentiate during larval-adult development and there is an increase in the complexity of clock cell axon arborizations, including the pathways connecting the two main groups of clock neurons (Vafoopoulou and Steel, 2012a). The circadian clock in the brain of adult *Rhodnius* (Fig. 16) resembles that described for other insects and includes two laterally symmetrical groups of clock neurons: the lateral clock neurons (LNs) and the dorsal clock neurons (DNs). In adult *Rhodnius*, there are 11 LNs located at the base of the optic lobe and roughly 150 DNs located in the posterior dorsal protocerebrum (Vafoopoulou and Steel, 2012a). Both groups of clock cells show circadian cycling of PER and TIM (Vafoopoulou and Steel, 2012a). The LNs and their axons stain abundantly with antibodies to the peptide pigment dispersing factor (PDF), whereas anti-PDF fluorescence is absent in the DNs, thus allowing the LN axons to be traced throughout the brain. The LNs extend axons to the DNs in the ipsilateral posterior protocerebrum and across the midline to the contralateral group of LNs. Axons from the LNs invade the mushroom body and the corpus cardiacum-allatum complex (CC-CA) and travel down the ventral nerve chord. Additionally, the PDF-positive LN axons arborize extensively in an area of the anterior protocerebrum referred to as the principal protocerebral arborization area (PPA), within which the presence of numerous

Figure 16: The brain clock system of adult *Rhodnius* (from Vafopoulou and Steel, 2012a). See text for details. ACC, adult-specific clock cell; aMe, accessory medulla; DNs, dorsal clock neurons; Ip, inflection point; La, lamina; LNd, dorsal lateral clock neurons; LNm, medial lateral clock neurons; LNv, ventral lateral clock neurons; Me, medulla; ml, midline; MNC, medial neurosecretory cell; PPA, primary protocerebral arborization area.

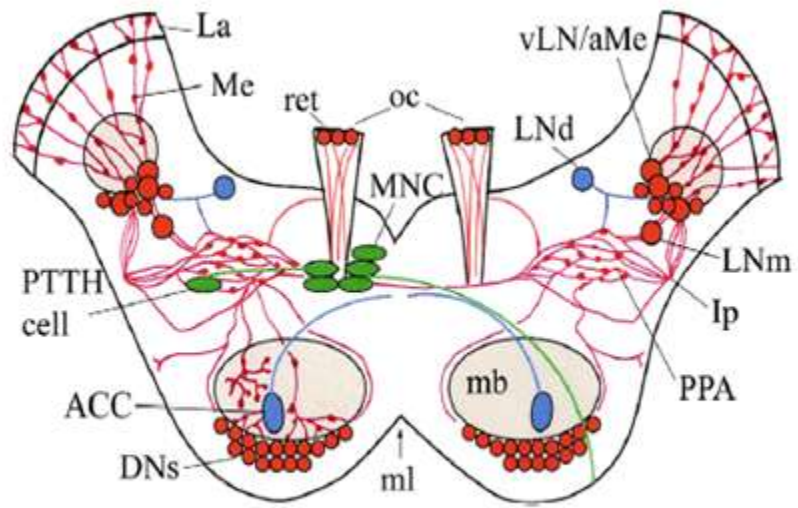

varicosities suggests the possibility of synaptic communication with axons from other neuron types, including neuroendocrine cells. Therefore, the clock neurons and their axons are well positioned within the *Rhodnius* central nervous system to control behavioural and hormonal rhythms.

3.2 *The clock in the brain controls rhythms of neuropeptides*

The cerebral neuropeptide prothoracicotropic hormone (PTTH) regulates critical developmental transitions in larval insects (Rybszczyński, 2009) and is a central component of the larval circadian system that orchestrates larval-adult development (Steel and Vafopoulou, 2006). The only known target of PTTH, the ecdysteroid producing prothoracic glands (PGs), are absent in adult insects and PTTH is therefore generally considered a strictly larval hormone (Rybszczyński, 2009). However, PTTH was originally purified from the brains of adult moths (Kataoka et al., 1987, 1991) and PTTH immunoreactive neurons have been identified in the brains of adult *Manduca sexta* (Westbrook et al., 1993) and *Rhodnius prolixus* (Vafopoulou et al., 2007). In fact, the adult *Rhodnius* brain contains roughly double the number of PTTH-immunoreactive neurons than does the larval brain (Vafopoulou et al., 2007). Additionally, PTTH mRNA expression has been reported in several neurons in the brain of *Drosophila* (McBrayer et al., 2007) and from the head of the mosquito *Culex pipiens* (Zhang and Denlinger, 2011).

The PTTH peptide has now been demonstrated to be present in adult *Rhodnius* and to be released during the period of egg development and oviposition (Chapter 2; Vafopoulou et al., 2012), suggesting that PTTH is involved in adult physiology. The brain of unfed *Rhodnius* contains, but does not release, PTTH; PTTH release is triggered

by a blood meal, which also initiates a cycle of egg development (Chapter 2; Vafopoulou et al., 2012). Moreover, both the content of PTTH in the brain and the amount of PTTH released by the brain vary with clear daily rhythms throughout the period of oogenesis and egg laying (Chapter 2; Vafopoulou et al., 2012). PTTH content peaks during the photophase, whereas PTTH release peaks during the scotophase, such that the rhythms of PTTH synthesis and release occur in almost complete anti-phase (Chapter 2; Vafopoulou et al., 2012). The rhythms in PTTH content and release are under circadian control and are influenced by light cues (Chapter 3, Cardinal-Aucoin and Steel, in prep.). Double-labelling experiments revealed that the PTTH cells extend axons into the PPA where they form close associations with PDF-positive axons from the LNs before passing into the CC-CA (Vafopoulou et al., 2007). It is inferred that a direct pathway between the LNs and PTTH cells mediates the clock control of PTTH synthesis and release. These results suggest that PTTH plays a role in the biology of the adult insect and that it is likely involved in the adult circadian system.

Insulin-like peptides (ILPs), such as bombyxin, are also under circadian control in adult *Rhodnius* (Vafopoulou and Steel, 2012b). ILPs are multifunctional peptides that have known roles in both larval and adult insects (review by Wu and Brown, 2006), including in the regulation of ecdysteroid production (Graf et al., 1997; Vafopoulou and Steel, 2002; Manière et al., 2004; Brown et al., 2008; Gu et al., 2009), reproduction (Badisco et al., 2011; Richard et al. 2005, Brown et al. 2008), metabolism (Satake et al., 1997; Masumura et al., 2000), haematopoiesis (Nakahara et al., 2006) and growth (Brogiolo et al., 2001). In adult *Rhodnius*, four bilaterally symmetrical groups of cells in

the brain, including a number of the medial neurosecretory cells (MNCs), show substantial bombyxin fluorescence (Vafopoulou and Steel, 2012b). Fluorescence within these ILP neurons and their axons exhibits a strong daily rhythm that was confirmed by western blot analysis (Vafopoulou and Steel, 2012b). ILP is synthesized each photophase and released each scotophase (Vafopoulou and Steel, 2012b), thus the ILP rhythm is synchronized with that of PTTH described above. The course of some ILP cell axons was traced directly to the CC-CA complex, in which numerous varicosities indicate the site of release (Vafopoulou and Steel, 2012b). Double-labelling with anti-PDF revealed an intimate relationship between certain ILP cell axons and axons from the LNs, providing a pathway for clock control of ILPs in *Rhodnius* (Vafopoulou and Steel, 2012b). Therefore, in adult female *Rhodnius*, the circadian clock in the brain controls the rhythmic synthesis and release of at least two neurohormones, PTTH and ILPs.

3.3 The ovaries release ecdysteroids into the hemolymph with a circadian rhythm

Ecdysteroids, produced by the larval PGs, coordinate insect development and metamorphosis and ecdysteroidogenesis by the PGs is stimulated by PTTH. In *Rhodnius*, the PTTH-ecdysteroid axis forms the central element of the larval circadian system (Steel and Vafopoulou, 2006). Ecdysteroids are also present in adult insects, though generally at lower levels than in larvae (Hagedorn, 1985; Brown et al., 2009) and their function in adult biology is often less clear. However, the larval PGs are absent in adults and various alternate sources of ecdysteroids have been reported, including the adult gonads (Delbecque et al., 1990; Brown et al., 2009). Ecdysteroids have been identified in the hemolymph of adult female *Rhodnius* (Chapter 4, Cardinal-Aucoin et al., 2013). The

unfed insect contains no detectable ecdysteroids; feeding a blood meal triggers egg development and concurrently elicits an initial rise in hemolymph ecdysteroids followed by a second increase in hemolymph titer several days later (Chapter 4, Cardinal-Aucoin et al., 2013). This two step pattern of ecdysteroid levels was also observed in the ecdysteroid content of ovaries and in the amount of ecdysteroids released by ovaries incubated *in vitro* (Chapter 4, Cardinal-Aucoin et al., 2013). Ecdysteroids have been associated with egg development and oviposition in other insects (Bullière et al., 1979; Rubenstein et al., 1982; Zhu et al., 1983; Stay et al., 1984; Weaver et al., 1984; Wilps and Zöller, 1989; Hoffman et al., 1992; Pascual et al., 1992; Chen and Kelly, 1993).

Superimposed on the hemolymph and ovarian ecdysteroid level profiles throughout the period of egg development and oviposition is an obvious daily rhythm with peaks each scotophase (Chapter 4, Cardinal-Aucoin et al., 2013). This daily rhythm was found to be under circadian control (Chapter 4, Cardinal-Aucoin et al., 2013). The parallel hemolymph and ovarian ecdysteroid profiles and synchronous rhythms combined with the observation that the ovaries were the only tissue examined that both contained and released ecdysteroids *in vitro* strongly argue that the ovaries are the source of rhythmic ecdysteroids in the hemolymph. The clock controlling the ecdysteroid rhythms may therefore reside within the ovaries themselves, though this need not be the case.

The ovarian follicle cells of the locust *Locusta* (Goltzené et al., 1978) and the cockroach *Nauphoeta* (Zhu et al., 1983) have been found to synthesize ecdysteroids and the same cells were shown to express enzymes of the ecdysone biosynthetic pathway in the silkworm, *Bombyx* (Ito et al., 2008) and some flies (Ono et al., 2006). In adult

Rhodnius the follicular epithelium surrounding vitellogenic oocytes consists of a homogeneous population of binucleate cells (Patchin and Davey, 1968; Huebner and Anderson, 1972b) that exhibit pronounced gap junctions that are retained throughout vitellogenesis (Huebner and Anderson, 1972b). Calcium action potentials generated by the developing oocyte are transmitted along the overlying follicular epithelium (O'Donnell, 1985). The follicular epithelium of adult *Rhodnius* therefore shares many properties with the autonomous photosensitive clock described in the larval *Rhodnius* PGs which is formed of a homogeneous population of about 200 cells that are coupled electrically by gap junctions (Vafopoulou and Steel, 1998). All these features are also seen in clocks in other systems, such as the molluscan eye clock (Jacklet, 1988), the non-mammalian vertebrate pineal gland clock (Berthoud et al., 2000; Fukuda and Okano, 2002), and the mammalian suprachiasmatic nuclei (SCN) clock (Colwell, 2000; 2005). However, Period mRNA (Hardin, 1994) and PER protein (Saez and Young, 1988; Kotwica et al., 2009) have been detected in *Drosophila* ovarian follicle cells, but found not to cycle. Moreover, in *Drosophila*, PER staining is predominantly cytoplasmic (Saez and Young, 1988; Kotwica et al., 2009; Beaver et al., 2003) and these authors have suggested that PER within the ovaries of this insect may possess functions outside of the clock and may be developmentally regulated. The origin of ecdysteroid rhythmicity and the regulation and function of PER in *Rhodnius* ovarian follicle cells remain to be investigated.

The temporal regulation of steroid hormone synthesis by the ovaries likely involves the clock control of one or several key biosynthetic enzymes, as is the case for

the circadian regulation of the enzyme arylalkylamine *N*-acetyltransferase (AANAT) in melatonin synthesis by the pineal (Klein and Weller, 1970; reviewed by Ganguly et al., 2002). The ecdysteroid biosynthetic pathway involves a set of genes originally identified in *Drosophila*, known as the Halloween genes, that code for cytochrome P₄₅₀ enzymes (Gilbert et al., 2002; Gilbert, 2004) and may potentially be under circadian control. The rate limiting step in steroid hormone synthesis is the translocation of cholesterol across the mitochondrial membrane in steroid producing cells and is mediated by the steroidogenic acute regulatory protein (StAR) (reviewed by Stocco, 2001). Therefore, StAR represents an attractive candidate as a potential target for the circadian control of steroidogenesis. In mammals, *Star* expression has been shown to vary during a day, paralleling the rhythm of plasma corticosterone levels and clock gene expression in adrenal cortex (Girotti et al., 2009, Fahrenkrug et al., 2012). The *Star* gene in rat adrenocortical (Son et al., 2008) and chicken ovarian granulosa cells (Nakao et al., 2007) is flanked by an E-box enhancer recognized by the CLOCK:BMAL1 heterodimer (Son et al., 2008), suggesting clock control of *Star* transcription. Additionally, down-regulation of *BMAL1* was recently shown to attenuate expression of progesterone-related biosynthetic enzymes, including *Star*, in rat granulosa cells (Chen et al., 2013). A putative homologous protein, Start1, has been identified in *Drosophila melanogaster* (Roth et al., 2004) and *Aedes gambiae* (Sieglaff et al., 2005) and has been associated with ecdysteroid biosynthesis. Circadian regulation of insect Start1 has not been demonstrated. A BLAST (<http://blast.ncbi.nlm.nih.gov/Blast.cgi>) search showed that the trace archive of the shotgun *Rhodnius prolixus* genome contains sequences with 31%, 49%, and 54%

similarity to the human *Star* (Genbank accession no. P49675), *Drosophila Start1* (Genbank accession no. Q9W145), and *Aedes gambiae Start1* (Genbank accession no. EAA03945), respectively. Clock control of the StAR-related protein in *Rhodnius* may provide a mechanism for the regulation of rhythmic ecdysteroid release described here.

The function of ecdysteroids in adults is not as clear as its well studied role in larval development. Ovarian ecdysteroids are known to be both stored in the ovaries and released into the hemolymph and this dual role of ecdysteroids seems likely to apply to the *Rhodnius* system (Chapter 4, Cardinal-Aucoin et al., 2013). Ecdysteroids are often conjugated and stored in developing oocytes and function in the regulation of embryonic molts (Lagueux et al., 1979, 1981; Sall et al. 1983; Dinan 1997; Tawfik et al. 1999; Sonobe and Yamada 2004; reviewed by Swevers and Iatrou, 2009). Unconjugated ecdysteroids released into the hemolymph, as in *Rhodnius*, can act as hormones in the adult insect.

Ecdysteroids in adult hemolymph have often been associated with reproductive processes, such as egg development, maturation, and oviposition (Hagedorn, 1985; Raikhel et al., 2005; Brown et al., 2009), but the specific targets of ecdysteroids in adults are mostly unknown. Ecdysteroids act on target tissues via their receptor, a heterodimer formed of the ecdysteroid receptor (EcR) and Ultraspiracle (Usp) (Henrich 2009). The expression of EcR in adult insects has received little attention. EcR has been observed in a variety of adult tissues in *Drosophila* (Schweddes et al., 2011), including fat body and ovaries. EcR has also been reported in the brain of an adult ant (Nemoto and Hara, 2007). In adult *Rhodnius* feeding a blood meal triggers an increase in ecdysteroid levels in the

hemolymph (Chapter 4, Cardinal-Aucoin et al., 2013) and concurrently leads to the expression of EcR in fat body (Saroiu, T., Undergraduate Thesis). Moreover, EcR fluorescence cycles in fat body (Saroiu, T., Undergraduate Thesis) in synchrony with the rhythm of hemolymph ecdysteroid titer, indicating that this tissue receives and responds to the timing information inherent in the rhythmic ecdysteroid signal. However, the extent to which EcR is distributed within adult tissues and therefore the targets of ecdysteroids in the adult insect remains to be investigated.

Recent evidence from this lab suggests the possibility that the rhythm of ecdysteroids in the hemolymph drives a rhythm of PER expression in the fat body (Saroiu, T., MSc Thesis). Vitellogenin production by fat body and uptake by oocytes are key events during egg growth and development and are known to be regulated by ecdysteroids in other insects (Raihkkel et al. 2005). The production of viable eggs ultimately leads to oviposition, which in *Rhodnius* is under circadian control (Ampleford and Davey, 1989). These results support a role for rhythmic ecdysteroids in egg development in adult *Rhodnius* and suggest the possibility of roles in other EcR-expressing tissues.

3.4 Potential hormonal interaction of brain and ovaries

In larval *Rhodnius*, clocks in the brain and PGs are known to communicate via rhythmic PTH to regulate rhythmic ecdysteroid synthesis by the PGs and ultimately orchestrate larval development (reviewed by Steel and Vafopoulou, 2006). ILPs have also been shown to stimulate ecdysteroidogenesis by larval *Rhodnius* PGs (Vafopoulou and Steel, 1997) and their release has now been shown to be under circadian control

(Vafopoulou and Steel, 2012b). Recently, both neuropeptides have been demonstrated to induce PER expression in PG cells (Vafopoulou and Steel, 2014). Therefore ILPs constitute a component of the larval circadian system and appear to be involved in some capacity in the regulation of the PG clock and ecdysteroid synthesis. The presence of all three hormones, PTTH, ILPs, and ecdysteroids, in adult female *Rhodnius* and their synchronous clock controlled rhythmic patterns of release during the period of egg development and oviposition (see Sections 3.2 and 3.3) suggest that these hormones may maintain a similar functional relationship as in larvae.

Transcript expression of the PTTH receptor torso, a receptor tyrosine kinase (RTK), has been reported in adult *Drosophila* ovaries (Rewitz et al., 2009), though the specific cell type(s) in which it is expressed was not investigated. The function of torso in adult ovaries remains unknown. An insulin receptor (IR) has been identified in ovarian cells of some species of Lepidoptera (Fullbright et al., 1997) and IR expression has been localized to the ovarian follicle and nurse cells that surround developing oocytes in several species of Diptera (Garofolo and Rosen, 1988; Helbling and Graf, 1998; Riehle and Brown, 2002; Lin et al., 2005). Additionally, ILPs and the related vertebrate insulin have been shown to stimulate ecdysteroid production by adult ovaries (Graf et al., 1997; Manière et al., 2004; Brown et al., 2008) and to be involved in the regulation of vitellogenesis and egg development (Richard et al. 2005, Brown et al. 2008; Badisco et al., 2011) in some species. The insulin signaling pathway is known, in adult female insects, to integrate nutritional information and egg development (reviewed Badisco et al., 2013) and therefore ILPs may incorporate nutritional status into the adult circadian

system. It has been suggested for larval *Rhodnius* that the coordination of cell responses during development may involve a concentration-dependent timed interplay of ILPs and ecdysteroids (Vafopoulou and Steel, 2012b). However, the exact roles of PTTH and ILPs within the adult circadian system require further investigation.

Juvenile hormone (JH), the 'status quo' hormone of larval insects, also plays an important role in the regulation of reproductive processes in adults (Wyatt and Davey, 1996; Goodman and Granger, 2009). Wigglesworth first implicated JH in the regulation of egg development in *Rhodnius* by showing that this process was inhibited by removal of the corpus allatum (CA), the site of synthesis of the hormone (Wigglesworth, 1936). JH has now been shown to mediate vitellogenin synthesis by the fat body and egg development by the ovaries in a variety of species (Wyatt and Davey, 1996; Goodman and Granger, 2009). In *Rhodnius*, PDF-containing LN axons extend into the CA where they exhibit numerous varicosities (Vafopoulou and Steel, 2012a), suggesting that JH synthesis may be under clock control. JH levels have been shown to be under circadian control in the cricket *Gryllus firmus* (Zhao and Zera, 2004; Zera and Zhao, 2009). However, the role of JH within the circadian system of *Rhodnius* or any insect and its interaction with PTTH, ILPs, and ecdysteroids remain to be investigated.

The proposed scheme for the organization of the circadian neuroendocrine system of adult female *Rhodnius* is illustrated in Fig. 17.

Figure 17: Organization of the circadian neuroendocrine system in adult *Rhodnius prolixus*. Clocks in the lateral clock neurons (LNs; red) and dorsal clock neurons (DNs; red) in the brain (Br) (Vafooulou and Steel, 2012a) are entrained by light. The LNs extend axons that make intimate associations with axons projecting from prothoracicotropic hormone producing cells (PTTH cells; blue) (Vafooulou et al., 2007) and insulin-like peptide producing cells (ILP cells; green) (Vafooulou and Steel, 2012b) resulting in a circadian rhythm of release of both PTTH (Chapter 2, Vafooulou et al., 2012; Chapter 3, Cardinal-Aucoin and Steel, in prep. a) and ILPs (Vafooulou and Steel, 2012b) from the brain via the corpus cardiacum (CC) and corpus allatum (CA). Within the ovaries (Ov; only one ovariole is depicted), follicle cells (FC) surrounding vitellogenic oocytes (Oo) may represent the site of ecdysteroid synthesis. The ovaries release ecdysteroids (Ecd) with a circadian rhythm and generate the rhythm seen in the hemolymph (Chapter 4, Cardinal-Aucoin et al., 2013). PTTH and ILPs may act on FC to regulate rhythmic ecdysteroid release. Ecds act on fat body (FB) and likely on FCs and other target tissues that express the ecdysteroid receptor. Juvenile hormone (JH) is produced by the CA, possibly rhythmically, and mediates vitellogenin (Vg) production by the FB and Vg uptake via FCs by developing Oo (Davey, 2007). Thus, the circadian neuroendocrine system precisely coordinates reproductive processes, such as egg development and oviposition, and establishes temporal order within the organism.

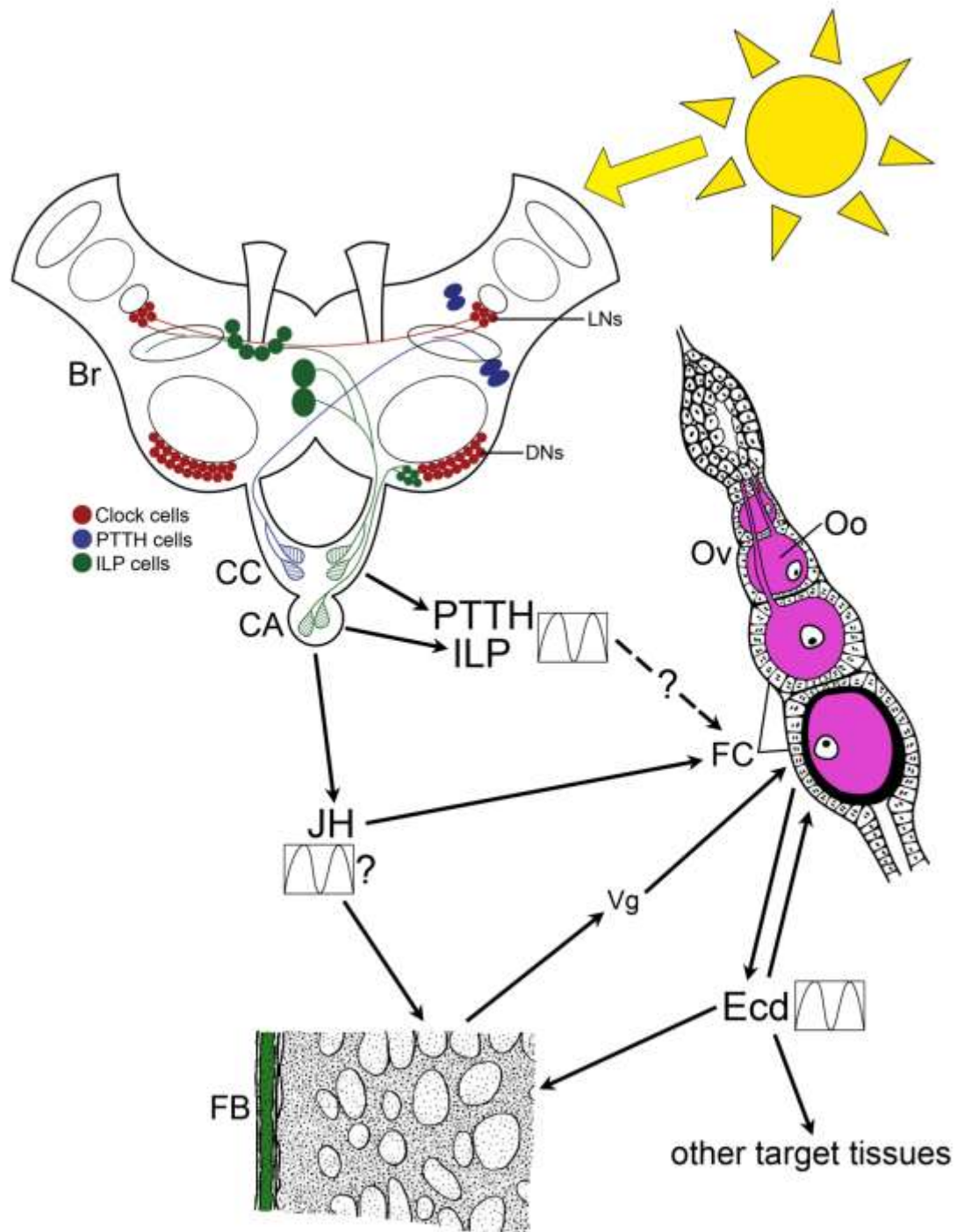

4. Circadian organization of the neuroendocrine system in adult male insects

Several pieces of evidence support the possibility that ecdysteroids, produced within male reproductive tissue, are under clock control and are influenced by the brain clock via multiple rhythmic peptide outputs, as in female *Rhodnius*. Ecdysteroids have been reported in adult males, however their source and roles are not well documented (Raikhel et al., 2005; Brown et al., 2009). The adult testes have been suggested as the site of ecdysteroid production in a few species (Raikhel et al., 2005; Brown et al., 2009), including *Spodoptera littoralis* (Polanska et al., 2009) and *Rhodnius* (Vafopoulou and Steel, 2005). In *Spodoptera*, Polanska et al. (2009) reported a circadian rhythm of ecdysteroid levels in the hemolymph and testes of adult males and argued that the testes may represent the source of rhythmic ecdysteroids. The authors further postulated a role for the ecdysteroids in the regulation of rhythmic sperm release (Polanska et al., 2009). Adult *Rhodnius* testes have been shown to release ecdysteroids *in vitro* and appear to be the source of ecdysteroids in the hemolymph of adult males (Vafopoulou and Steel 2005). Unfed adult males contain no detectable ecdysteroids and, similar to females, ecdysteroid levels in hemolymph and testes increase following a blood meal and continue to change in parallel for several days after feeding (Vafopoulou and Steel, 2005). The levels of ecdysteroids in adult males are considerably lower, up to several hundred times, than in adult females. In *Rhodnius*, feeding of 5th (last) instar males initiates spermiation so that adults emerge with fully viable spermatozoa (Dumser and Davey 1974). However, the processes of spermatogenesis continue in the adult and appear to be triggered by feeding since the weight of testes increases following feeding a blood meal. The coincident rise in

ecdysteroid levels and increase in testes weight suggests these events are related. The presence of ecdysteroids has been said to be required for the continuation of spermatogenesis in the adult stages of some species (Dumser, 1980). The rhythmicity of ecdysteroids in adult male *Rhodnius* has not yet been examined.

The brain neuropeptide testes ecdysiotropin (TE) stimulates ecdysteroid release by testes of *Lymantria dispar* (Loeb et al., 2001) and *Rhodnius* (Vafopoulou and Steel, 2005). In *Rhodnius*, TE is synthesized and released with a daily rhythm that is regulated by the circadian clock in the brain (Vafopoulou and Steel, 2012b). PTTH-immunoreactive cells are present in the brain of adult male *Rhodnius* and exhibit changes in fluorescence intensity consistent with a daily rhythm of synthesis and release of PTTH (Vafopoulou et al., 2007). Recently, Hentze et al. (2013) reported the expression of the PTTH receptor transcript in male accessory glands of adult *Drosophila*, suggesting these may be a target of PTTH. However, the accessory glands in *Drosophila* have not been shown to produce ecdysteroids nor has PTTH peptide been identified in adult *Drosophila*.

5. Comparison with the mammalian system

Clear parallels between the intercerebralis-cardiacum-allatum system of insects and the hypothalamus-pituitary system of vertebrates have been recognized primarily based on gross anatomical and functional characteristics (Scharrer and Scharrer, 1944; Hanström, 1948; Veelaert et al., 1998). Both systems are composed of a combination of neural and glandular tissue and are involved in the endocrine regulation of multiple physiological processes including growth, metabolism, and reproduction. The

development of the neuroendocrine systems in insects and mammals is also remarkably similar (Veelaert et al., 1998; Hartenstein, 2006). Precursors of both the vertebrate pituitary and insect corpus cardiacum (CC) are derived from an anterior anlage that develops an intimate association with the brain tissue from which it receives innervation. Remarkably, both organs also share regulatory genes and signaling pathways involved in their embryonic development (De Velasco et al., 2004).

The analogy can now be extended to include the extensive intersection between the circadian and neuroendocrine systems in both insects and mammals, in large part due to work from the Steel lab. The PTTH-ecdysteroid axis is central to the circadian system of larval *Rhodnius* (Steel and Vafopoulou, 2006) and is highly comparable to the mammalian hypothalamus-pituitary-adrenal (HPA) axis. This axis likely persists to some extent in adults with the ovaries replacing the PGs as the primary site of rhythmic ecdysteroid production and is comparable to the hypothalamic-pituitary-ovary (HPO) axis. The HPO axis appears to share a similar circadian organization with the HPA, though it is less well studied in this context.

At the molecular level, the circadian oscillator is organized very similarly in insects and mammals and many of the component genes and proteins share remarkable homology (Glossop, 2011). The molecular oscillator of *Drosophila* appears to have diverged somewhat from that of other insects in which the clockwork appears even more similar to that of mammals. For example, *Drosophila* possesses a single CRY protein that is light sensitive and functions in the light input pathway. A second CRY protein was discovered in the monarch butterfly, *Danaus plexxipus* (Zhu et al., 2005) and

subsequently identified in other insects including the honeybee *Apis mellifera* (Rubin et al., 2006) that is not light sensitive and behaves rather like mammalian CRY as a repressor in the TTFL.

The organization and function of the circadian clock in the brain of insects and mammals are astonishingly similar (reviewed by Helfrich-Förster, 2004). The circadian clock in the brain is strategically located to be able to receive light input from the eyes and to control outputs including behavioural and hormonal rhythms. The SCN in mammals and the LNs in *Rhodnius* regulate the rhythmic release of trophic peptide hormones, follicle stimulating hormone (FSH)/luteinizing hormone (LH) and PTH/ILPs, respectively. A circadian clock has been described in the ovaries of vertebrates, including mammals (Fahrenkrug et al., 2006; Karman and Tischkau, 2006; He et al., 2007; Yoshikawa et al., 2009; Chu et al., 2012) and birds (Nakao et al., 2007; Tischkau et al., 2011). Rhythmic clock gene expression has been reported in cells that are responsible for steroid hormone production (reviewed in Sellix and Menaker, 2010) and are analogous to the follicle and nurse cells in insects, cells known to produce ecdysteroids (Goltzené et al., 1978; Zhu et al., 1983) and express PER (Hardin, 1994; Saez and Young, 1988; Kotwica et al., 2009). Furthermore, the vertebrate ovarian clock appears to be influenced by gonadotropic peptide hormones from the brain. Karman and Tischkau (2006) associated LH with changes in expression of the clock genes *ARNT1* and *Per1* transcripts in rat ovaries and the gonadotropic neuropeptides LH and FSH have been shown to induce rhythmic expression of *Per1* and *Per2* mRNA in cultured rat granulosa cells (He et al., 2007). Some evidence suggests that ovarian clock genes may

regulate gonadotropin receptor expression in those same cells (Shimizu et al., 2011), regulating the sensitivity of the ovaries to gonadotropic hormones throughout the day. In chickens, LH has also been found to affect the expression of clock genes in ovaries *in vivo* (Tischkau et al., 2011) and to induce the rhythmic expression of the clock genes *Per1* and *Bmal1* in arrhythmic, cultured granulosa cells (Tischkau et al., 2011). Therefore, LH and FSH functionally connect the clock in the ovaries with the central clock in the brain into a multi-oscillator system that regulates the proper timing of reproductive processes such as steroid hormone production and ovulation.

6. General conclusions

This is the first systematic study of the physiological mechanisms by which temporal order is generated in an adult insect. It was demonstrated that PTTH is present in adult *Rhodnius* (Chapter 2, Vafopoulou et al., 2012) and that it is released *in vitro* (Chapter 2, Vafopoulou et al., 2012) and *in vivo* (Chapter 3, Cardinal-Aucoin and Steel, in prep.). This is the first time that the release of PTTH peptide has been shown in any adult insect. Moreover, the release of PTTH occurred with a daily rhythm throughout the period of egg development and oviposition (Chapter 2, Vafopoulou et al., 2012) and this rhythm persisted in aperiodic conditions indicating that it is under endogenous circadian control (Chapter 3, Cardinal-Aucoin and Steel, in prep.). The transfer of arrhythmic LL insects in which PTTH release had been completely eliminated quickly induced the rhythmic release of PTTH (Chapter 3, Cardinal-Aucoin and Steel, in prep.), confirming that PTTH is regulated by a photosensitive clock, most likely the LNs in the brain. These

results challenge the view that PTTH is a strictly larval hormone and demand a reappraisal of its role in adult physiology.

Ecdysteroids were also identified in adult *Rhodnius* (Chapter 4, Cardinal-Aucoin et al., 2013). The changing hemolymph titer during a gonotrophic cycle correlated with specific egg developmental events (Chapter 4, Cardinal-Aucoin et al., 2013), suggesting a relationship. The ovaries were identified as the only adult tissue that contained and released ecdysteroids (Chapter 4, Cardinal-Aucoin et al., 2013). The pattern of ecdysteroids released by ovaries *in vitro* paralleled the hemolymph titer (Chapter 4, Cardinal-Aucoin et al., 2013). Additionally, a daily rhythm of ecdysteroids was observed in the hemolymph that was matched by a synchronous rhythm of ecdysteroid release by the ovaries (Chapter 4, Cardinal-Aucoin et al., 2013). It is inferred that the ovaries are the major, possibly only, source of ecdysteroids in the adult insect and that they generate the rhythm seen in the hemolymph. The rhythms of ecdysteroids in the hemolymph and ovaries were shown to persist in constant conditions (Chapter 4, Cardinal-Aucoin et al., 2013) and are therefore regulated by the circadian system. Rhythmic ecdysteroid release may be governed by a clock residing within the ovaries themselves, as in mammals, or may be driven by a clock elsewhere in the insect, such as the known clock in the brain. The synchronous rhythms of neuropeptides (PTTH and ILPs) and ecdysteroids described here indicates these may be related and suggests the possibility that these peptides might drive or otherwise influence the rhythmic release of ecdysteroids by the ovaries.

The striking analogy between the insect and mammalian systems emphasizes the impressive conservation of circadian physiological regulatory mechanisms between

distantly related phyla and highlights their vital importance to the survival of the organism. The study of the more tractable *Rhodnius* system can therefore inform the fields of vertebrate circadian biology and human health. In fact, the *Rhodnius* ovaries offer a unique *in vitro* system with which to explore the integration of circadian information and the influence of various inputs on a rhythmic output, ecdysteroids. Additionally, the *Rhodnius* system can provide important insights into the circadian orchestration of complex biological processes such as larval development and oogenesis.

7. Future directions

Together, the findings presented herein establish a firm foundation for the study of the circadian physiology of the adult insect and open many new avenues for future research. Since the only known function of PTTH is to stimulate ecdysteroidogenesis by the larval PGs, it is not unreasonable to expect that it may remain involved in the regulation of ecdysteroids in adults. Studies of the expression and distribution of the PTTH receptor can determine whether the ovaries are among its targets and provide clues about its function in the adult. *In vitro* and *in vivo* investigations in which PTTH is provided experimentally may also be useful in determining its function in adults. The effect of PTTH on the properties of the ecdysteroid rhythm can reveal its role in the adult circadian system. As with PTTH, the targets of ecdysteroids in the adult can be ascertained by studies of the ecdysteroid receptor, EcR. The presence of ecdysteroids and PTTH in the adult insect and the systematic changes in their amounts during egg development suggest they may be involved in its regulation. These correlative observations can be strengthened by the use of RNAi or other methods to alter the levels

of hormones or their receptors. The role(s) of ILPs and JH in egg development and within the adult circadian system can also be investigated. The potential interaction of ILPs, JH, PTTH, and ecdysteroids in the circadian orchestration of egg development should be addressed.

REFERENCES

1. Chapter 2

Brown, M.R., Sieglaff, D.H., Rees, H.H., 2009. Gonadal ecdysteroidogenesis in Arthropoda: occurrence and regulation. *Annu. Rev. Entomol.* 54, 105–125.

Buxton, P.A., 1930. The biology of a blood-sucking bug, *Rhodnius prolixus*. *Trans. Roy. Entomol. Soc. London* 78, 227–236.

Cardinal-Aucoin, M., Rapp, N., Steel, C.G.H., 2013. Circadian regulation of hemolymph and ovarian ecdysteroids during egg development in the insect *Rhodnius prolixus* (Hemiptera). *Comp. Biochem. Physiol. A.*, 503-509.

Friend, W.G., Choy, C.T.H., Cartwright, E., 1965. The effect of nutrient intake on the development and the egg production of *Rhodnius prolixus* Stal. *Can. J. Zool.* 43, 891–904.

Fullbright, G., Lacy, E.R., Bullesbach, E.E., 1997. The prothoracicotropic hormone bombyxin has specific receptors on insect ovarian cells. *J. Biochem.* 245, 774–780.

Hagedorn, H.H., O'Connor, J.D., Fuchs, M.S., Sage, B., Schlaeger, D.A., Bohm, M.K., 1975. The ovary as a source of alpha-ecdysone in an adult mosquito. *Proc. Natl. Acad. Sci. U.S.A.* 72, 3255–3259.

Horn, D.H.S., Wilkie, J.S., Sage, B.A., O'Connor, J.D., 1976. A high affinity antiserum specific for the ecdysone nucleus. *J. Insect Physiol.* 22, 901–905.

Ishizaki, H., Suzuki, A., 1994. The brain secretory peptides that control molting and metamorphosis of the silkworm, *Bombyx mori*. *Int. J. Dev. Biol.* 38, 301–310.

Iwami, M., 2000. An insect brain peptide that belongs to the insulin family. *Zool. Sci.* 17, 1035–1044.

Kataoka, H., Nagasawa, H., Isogai, A., Tamura, S., Mizoguchi, A., Fujishita, Y., Suzuki, C., Ishizaki, H., Suzuki, A., 1987. Isolation and partial characterization of a prothoracicotropic hormone of the silkworm, *Bombyx mori*. *Agric. Biol. Chem. Tokyo* 51, 1067–1076.

Kopeč, S., 1922. Studies on the necessity of the brain for inception of insect metamorphosis. *Biol. Bull.* 42, 322–342.

Lane, N.J., Leslie, R.A., Swales, L.S., 1975. Insect peripheral nerves: accessibility of neurohaemal regions to lanthanum. *J. Cell Sci.* 18, 179–197.

Masumura, M., Satake, S.I., Saegusa, H., Mizoguchi, A., 2000. Glucose stimulates the

release of bombyxin, an insulin-related peptide of the silkworm *Bombyx mori*. *Gen. Comp. Endocrinol.* 118, 393–399.

McBrayer, Z., Ono, H., Shimell, M.J., Parvy, J.-P., Beckstead, R.B., Warren, J.T., Thummel, C.S., Dauphin-Villemant, C., Gilbert, L.I., O'Connor, M.B., 2007. Prothoracicotropic hormone regulates developmental timing and body size in *Drosophila*. *Dev. Cell.* 13, 857–871.

Mizoguchi, A., Oka, T., Kataoka, H., Nagasawa, H., Suzuki, A., Ishizaki, H., 1990. Immunohistochemical localization of prothoracicotropic hormone-producing neurosecretory cells in the brain of *Bombyx mori*. *Dev. Growth Differ.* 32, 591–598.

Nagasawa, H., Kataoka, H., Isogai, A., Tamura, S., Suzuki, Y., Ishizaki, H., Mizoguchi, A., Fujiwara, Y., Suzuki, A., 1984. Amino-terminal amino-acid sequence of the silkworm prothoracicotropic hormone: homology with insulin. *Science* 226, 1344–1345.

Nakahara, Y., Matsumoto, H., Kanamori, Y., Kataoka, H., Mizoguchi, A., Kiuchi, M., Kamimura, M., 2006. Insulin signaling is involved in hematopoietic regulation in an insect hematopoietic organ. *J. Insect Physiol.* 52, 105–111.

Nijhout, H.F., Grunert, L.W., 2002. Bombyxin is a growth factor for wing imaginal disks in Lepidoptera. *Proc. Natl. Acad. Sci. U.S.A.* 99, 15445–15450.

Nijhout, H.F., Smith, W.A., Achachar, I., Subramanian, S., Tobler, A., Grunert, L.W., 2007. The control of growth and differentiation of the wing imaginal disks of *Manduca sexta*. *Dev. Biol.* 302, 569–576.

Noguti, T., Adachi-Yamada, T., Katagiri, T., Kawakami, A., Iwami, M., Ishibashi, J., Kataoka, H., Suzuki, A., Go, M., Ishizaki, H., 1995. Insect prothoracicotropic hormone: a new member of the vertebrate growth factor superfamily. *FEBS Lett.* 376, 251–256.

Pelc, D., Steel, C.G.H., 1997. Rhythmic steroidogenesis by the prothoracic glands of the insect *Rhodnius prolixus* in the absence of rhythmic neuropeptide input: implications for the role of prothoracicotropic hormone. *Gen. Comp. Endocrinol.* 108, 358–365.

Pratt, G.E., Davey, K.G., 1972. The corpus allatum and oogenesis in *Rhodnius prolixus* (Stal.) I. The effect of allatectomy. *J. Exp. Biol.* 56, 201–214.

Raihkel, A.S., Brown, M.R., Belles, X., 2005. Hormonal control of reproductive processes. In: Gilbert, L.I., Iatrou, K., Gill, S.W. (Eds.), *Comprehensive Molecular Insect Science*, vol. 3. Elsevier, Oxford, pp. 433–491.

Riddiford, L.M., Hiruma, K., Zhou, X.F., Nelson, C.A., 2003. Insights into the molecular

basis of the hormonal control of molting and metamorphosis from *Manduca sexta* and *Drosophila melanogaster*. *Insect Biochem. Mol. Biol.* 33, 1327–1338.

Rybczynski, R., 2009. Prothoracicotropic hormone. In: Gilbert, L.I. (Ed.), *Insect Development: Morphogenesis, molting and metamorphosis*. Academic Press, London, pp. 197–259.

Rybczynski, R., Snyder, C.A., Hartmann, J., Gilbert, L.I., 2009. *Manduca sexta* prothoracicotropic hormone: evidence for a role beyond steroidogenesis. *Arch. Insect Biochem. Physiol.* 70, 217–229.

Satake, S.I., Masumura, M., Ishizaki, H., Nagata, K., Kataoka, H., Suzuki, A., Mizoguchi, A., 1997. Bombyxin, an insulin-related peptide of insects, reduces the major storage carbohydrates in the silkworm *Bombyx mori*. *Comp. Biochem. Physiol. B* 349–357.

Steel, C.G.H., Vafopoulou, X., 2006. Circadian orchestration of developmental hormones in the insect, *Rhodnius prolixus*. *Comp. Biochem. Physiol. A* 144, 351–364.

Steel, C.G.H., Bollenbacher, W.E., Smith, S.L., Gilbert, L.I., 1982. Haemolymph ecdysteroid titres during larval–adult development in *Rhodnius prolixus*: correlations

with molting hormone action and brain neurosecretory cell activity. *J. Insect Physiol.* 28, 519–525.

Vafopoulou, X., 2009. Ecdysteroid receptor (EcR) is associated with microtubules and with mitochondria in the cytoplasm of prothoracic gland cells of *Rhodnius prolixus* (Hemiptera). *Arch. Insect Biochem. Physiol.* 72, 249–262.

Vafopoulou, X., Steel, C.G.H., 1989. Developmental and diurnal changes in ecdysteroid biosynthesis by prothoracic glands of *Rhodnius prolixus* (Hemiptera) in vitro during the last larval instar. *Gen. Comp. Endocrinol.* 74, 484–493.

Vafopoulou, X., Steel, C.G.H., 1991. Circadian regulation of synthesis of ecdysteroids by prothoracic glands of the insect *Rhodnius prolixus*: evidence of a dual oscillator system. *Gen. Comp. Endocrinol.* 83, 27–34.

Vafopoulou, X., Steel, C.G.H., 1993. Release in vitro of prothoracicotropic hormone from the brain of male *Rhodnius prolixus* during larval–adult development: identification of novel and predicted release times. *J. Insect Physiol.* 39, 65–71.

Vafopoulou, X., Steel, C.G.H., 1996a. The insect neuropeptide prothoracicotropic hormone is released with a daily rhythm: re-evaluation of its role in development. *Proc. Natl. Acad. Sci. U.S.A.* 93, 3368–3372.

Vafopoulou, X., Steel, C.G.H., 1996b. Circadian regulation of a daily rhythm of release of prothoracicotropic hormone from the brain-retrocerebral complex of *Rhodnius prolixus* (Hemiptera) during larval–adult development. *Gen. Comp. Endocrinol.* 102, 123–129.

Vafopoulou, X., Steel, C.G.H., 1997. Ecdysteroidogenic action of *Bombyx* prothoracicotropic hormone and bombyxin on the prothoracic glands of *Rhodnius prolixus* in vitro. *J. Insect Physiol.* 43, 641–656.

Vafopoulou, X., Steel, C.G.H., 2002. Prothoracicotropic hormone of *Rhodnius prolixus*: partial characterization and rhythmic release of neuropeptides related to *Bombyx* PTTH and bombyxin. *Invert. Reprod. Dev.* 42, 111–120.

Vafopoulou, X., Steel, C.G.H., 2005. Testis ecdysiotropic peptides in *Rhodnius prolixus*: biological activity and distribution in the nervous system and testis. *J. Insect Physiol.* 51, 1227–1239.

Vafopoulou, X., Steel, C.G.H., 2006. Ecdysteroid hormone nuclear receptor (EcR) exhibits circadian cycling in certain tissues, but not others, during development in *Rhodnius prolixus* (Hemiptera). *Cell Tissue Res.* 323, 443–455.

Vafopoulou, X., Steel, C.G.H., 2009. Circadian organization of the endocrine system. In: Gilbert, L.I. (Ed.), *Insect Development: Morphogenesis, Molting, and Metamorphosis*. Academic Press, London, pp. 395–458.

Vafopoulou, X., Steel, C.G.H., 2012a. Metamorphosis of a clock: remodelling of the circadian timing system in the brain of *Rhodnius prolixus* (Hemiptera) during larval-adult development. *J. Comp. Neurol.* 520, 1146-1164.

Vafopoulou, X., Steel, C.G.H., 2012b. Insulin-like and testis ecdysiotropin neuropeptides are regulated by the circadian timing system in the brain during larval-adult development in the insect *Rhodnius prolixus* (Hemiptera). *Gen. Comp. Endocrinol.* 179, 277-288.

Vafopoulou, X., Sim, C.-H., Steel, C.G.H., 1996. Prothoracicotropic hormone in *Rhodnius prolixus*: in vitro analysis and changes in amounts in the brain and retrocerebral complex during larval–adult development. *J. Insect Physiol.* 42, 407–415.

Vafopoulou, X., Steel, C.G.H., Terry, K.L., 2005. Ecdysteroid receptor (EcR) shows marked differences in temporal patterns between tissues during larval–adult development in *Rhodnius prolixus*: correlations with haemolymph ecdysteroid titres. *J. Insect Physiol.* 51, 27–38.

Vafopoulou, X., Steel, C.G.H., Terry, K.L., 2007. Neuroanatomical relations of prothoracicotropic hormone neurons with the circadian timekeeping system in the brain of larval and adult *Rhodnius prolixus* (Hemiptera). *J. Comp. Neurol.* 503, 511–524.

Vafopoulou, X., Terry, K.L., Steel, C.G.H., 2010. The circadian timing system in the brain of the fifth larval instar of *Rhodnius prolixus* (Hemiptera). *J. Comp. Neurol.* 518, 1264–1282.

Warren, J.T., Bachmann, J.S., Dai, J.D., Gilbert, L.I., 1996. Differential incorporation of cholesterol and cholesterol derivatives into ecdysteroids by the larval ring gland and adult ovaries of *Drosophila melanogaster*: a putative explanation for the l(3) ecd1 mutation. *Insect Biochem. Mol. Biol.* 26, 931–943.

Wei, A.-J., Zhang, Q.R., Kang, L., Xu, W.-H., Denlinger, D.L., 2005. Molecular characterization and expression of prothoracicotropic hormone during development and pupal diapause in the cotton bollworm, *Helicoverpa armigera*. *J. Insect Physiol.* 51, 691–700.

Wigglesworth, V.B., 1940. The determination of characters at metamorphosis in *Rhodnius prolixus* (Hemiptera). *J. Exp. Biol.* 17, 201–222.

Wigglesworth, V.B., 1952. The thoracic gland in *Rhodnius prolixus* (Hemiptera) and its

role in moulting. J. Exp. Biol. 29, 561–570.

Wigglesworth, V.B., 1955. The breakdown of the thoracic gland in the adult insect *Rhodnius prolixus*. J. Exp. Biol. 32, 485–491.

Willams, C.M., 1947. Physiology of insect diapause II. Interaction between the pupal brain and prothoracic glands in the metamorphosis of the giant silkworm, *Platysamia cercropia*. Biol. Bull. 93, 89–98.

Zhang, Q., Denlinger, D.L., 2011. Molecular structure of the prothoracicotropic hormone gene in the northern house mosquito, *Culex pipiens*, and its expression analysis in association with diapause and blood feeding. Insect Mol. Biol. 20, 201–213.

2. Chapter 3

Ampleford, E.J., Davey, K.G., 1989. Egg laying in the insect *Rhodnius prolixus* is timed in a circadian fashion. J. Insect Physiol. 35, 183–187.

Ampleford, E.J., Steel C.G.H., 1982. Circadian control of ecdysis in *Rhodnius prolixus* (Hemiptera). J. Comp. Physiol. 147, 281–286.

Ampleford, E.J., Steel, C.G.H., 1985. Circadian control of a daily rhythm in hemolymph ecdysteroid titer in the insect *Rhodnius prolixus* (Hemiptera). *Gen. Comp. Endocrinol.* 59, 453-459.

Bowen, M.F., Saunders, D.S., Bollenbacher, W.E., Gilbert, L.I., 1984. *In vitro* reprogramming of the photoperiodic clock in an insect brain-retrocerebral complex. *Proc. Natl. Acad. Sci. USA* 81, 5881–5884.

Brown, M.R., Graf, R., Swiderek, K.M., Fendley, D., Stracker, T.H., Champagne, D.E., Lea, A.O., 1998. Identification of a steroidogenic neurohormone in female mosquitoes. *J. Biol. Chem.* 273, 3967–3971.

Cardinal-Aucoin, M., Rapp, N., Steel, C.G.H., 2013. Circadian regulation of hemolymph and ovarian ecdysteroids during egg development in the insect *Rhodnius prolixus* (Hemiptera). *Comp. Biochem. Physiol. A.* 166, 503-509.

Chavez V.M., Marques, G., Delbecque, J.P., Kobayashi, K., Hollingsworth, M., Burr, J., Natzle J.E., O'Connor, M.B., 2000. The *Drosophila* disembodied gene controls late embryonic morphogenesis and codes for a cytochrome P450 enzyme that regulates embryonic ecdysone levels. *Development* 127, 4115–4126.

Claeys, I., Simonet, G.J.P., Van Loy, T., Vercammen, L., De Loof, A., Vanden Broeck, J., 2002. Insulin-related peptides and their conserved signal transduction pathway. *Peptides*, 23, 807–816.

Daan, S., Pittendrigh, C.S., 1976. A functional analysis of circadian pacemakers in nocturnal rodents. *J. Comp. Physiol.* 106, 267–290.

Fullbright, G., Lacy, E.R., Büllesbach, E.E., 1997. The prothoracicotropic hormone bombyxin has specific receptors on insect ovarian cells. *Eur. J. Biochem.*, 245, 774–780.

Garofalo, R.S., 2002. Genetic analysis of insulin signaling in *Drosophila*. *Trends Endocrin. Met.* 13, 156–162.

Gilbert, L.I., Goodman, W., Bollenbacher, W.E., 1977. Biochemistry of regulatory lipids and sterols in insects. *Int. Rev. Biochem.* 14, 1-50.

Goltzené, F., Lagueux, M., Charlet, M., Hoffmann, J.A., 1978. The follicle cell epithelium of maturing ovaries of *Locusta migratoria*: a new biosynthetic tissue for ecdysone. *H.-S. Z. Physiol. Chem.* 359, 1427–1434.

Graf, R., Neuenschwander, S., Brown, M.R., Ackermann, U., 1997. Insulin-mediated secretion of ecdysteroids from mosquito ovaries and molecular cloning of the insulin

receptor homologue from ovaries of bloodfed *Aedes aegypti*. *Insect Mol. Biol.* 6, 151–163.

Hagedorn, H.H., O'Connor, J.D., Fuchs, M.S., Sage, B., Schlaeger, D.A., Bohm, M.K., 1975. The ovary as a source of α -ecdysone in an adult mosquito. *Proc. Nat. Acad. Sci. USA* 72, 3255-3259.

Hagedorn, H.H., 1985. The role of ecdysteroids in reproduction. In: Kerkut, G.A., L.I. Gilbert (Eds.), *Comprehensive Insect Physiology, Biochemistry, and Pharmacology*, vol. 8. Pergamon Press Ltd., Oxford, England, pp. 205-262.

Helbling, P., Graf, R., 1998. Localization of the mosquito insulin receptor homologue (MIR) in reproducing yellow fever mosquitoes (*Aedes aegypti*). *J. Insect Physiol.* 44, 1127–1135.

Horn, D.H.S., Wilkie, J.S., Sage, B.A., O'Connor, J.D., 1976. A high affinity antiserum specific for the ecdysone nucleus. *J. Insect Physiol.* 22, 901-905.

Johnson, C.H., Elliott, J., Foster, R., Honma, K., Kronauer, R.E., 2004. Fundamental properties of circadian rhythms. In: Dunlap, J., Loros, J., DeCoursey, P.J. (Eds.), *Chronobiology*. Sinauer Associates, Sunderland, MA, pp. 67–105.

Kataoka, H., Nagasawa, H., Isogai, A., Tamura, S., Mizoguchi, A., Fujishita, Y., Suzuki, C., Ishizaki, H., Suzuki, A., 1987. Isolation and Partial Characterization of a Prothoracicotropic Hormone of the Silkworm, *Bombyx mori*. *Agr. Biol. Chem. Tokyo* 51, 1067-1076.

Kataoka, H., Nagasawa, H., Isogai, A., Ishizaki, H., Suzuki, A., 1991. Prothoracicotropic hormone of the silkworm, *Bombyx mori*: Amino acid sequence and dimeric structure. *Agric. Biol. Chem.* 55, 73–86.

Kopeč, S., 1922. Studies on the Necessity of the Brain for Inception of Insect Metamorphosis. *Biol. Bull.* 42, 322-342.

Lane, N.J., Leslie, R.A., Swales, L.S., 1975. Insect peripheral nerves: accessibility of neurohaemal regions to lanthanum. *J. Cell Sci.* 18, 179-197.

Manière, G., Rondot, I., Büllsbach, E.E., Gautron, F., Vanhems, E., Delbecq, J.P., 2004. Control of ovarian steroidogenesis by insulin-like peptides in the blowfly (*Phormia regina*). *J. Endocrinol.* 181, 147–156.

McBayer, Z., Ono, H., Shimell, M.J., Parvy, J.-P., Beckstead, R.B., Warren, J.T., Thummel, C.S., Dauphin-Villemant, C., Gilbert, L.I., O'Connor, M.B., 2007.

Prothoracicotrophic hormone regulates developmental timing and body size in *Drosophila*,
Dev. Cell. 13, 857-871.

Mizoguchi, A., Oka, T., Kataoka, H., Nagasawa, H., Suzuki, A., Ishizaki, H., 1990.
Immunohistochemical localization of prothoracicotrophic hormone-producing
neurosecretory cells in the brain of *Bombyx mori*. Dev. Growth Differ. 32, 591-598.

Pelc, D., Steel, C.G.H., 1997. Rhythmic Steroidogenesis by the Prothoracic Glands of the
Insect *Rhodnius prolixus* in the Absence of Rhythmic Neuropeptide Input: Implications
for the Role of Prothoracicotrophic Hormone. Gen. Comp. Endocrinol. 108, 358-365.

Raihkel, A.S., Brown, M.R., Belles, X., 2005. Hormonal Control of Reproductive
Processes. In: Gilbert, L.I., Iatrou, K., Gill, S.W. (Eds.), Comprehensive Molecular Insect
Science, vol. 3. Elsevier, Oxford, pp. 433-491.

Rewitz, K.F., Yamanaka, N., Gilbert, L.I., O'Connor, M.B., 2009. The insect
neuropeptide PTTH activates receptor tyrosine kinase Torso to initiate metamorphosis.
Science 326, 1403-1405.

Riehle, M.A., Brown, M.R., 1999. Insulin stimulates ecdysteroid production through a
conserved signaling cascade in the mosquito *Aedes aegypti*. Insect Biochem. Mol. Biol.
29, 855-860.

Riehle, M.A., Brown, M.R., 2002. Insulin receptor expression during development and a reproductive cycle in the ovary of the mosquito *Aedes aegypti*. *Cell Tissue Res.* 308, 409–420.

Rubenstein, E.C., Kelly, T.J., Schwartz, M.B., Woods, C.W., 1982. In vitro synthesis and secretion of ecdysteroids by *Drosophila melanogaster* ovaries. *J. Exp. Zool.* 223, 305–308.

Rybczynski, R., 2009. Prothoracicotropic hormone. In: Gilbert, L.I. (Ed.), *Insect Development: Morphogenesis, molting and metamorphosis*. Academic Press, London, pp. 197–259.

Sauman, I., Reppert, S.M., 1996. Molecular characterization of prothoracicotropic hormone (PTTH) from the giant silkworm *Antheraea pernyi*: developmental appearance of PTTH-expressing cells and relationship to circadian clock cells in the central brain. *Developmental Biology* 178, 418–429.

Steel, C.G.H., Bollenbacher, W.E., Smith, S.L., Gilbert, L.I., 1982. Haemolymph ecdysteroid titres during larval-adult development in *Rhodnius prolixus*: Correlations with molting hormone action and brain neurosecretory cell activity. *J. Insect Physiol.* 28, 519–525.

Steel, C.G.H., Vafopoulou, X., 2006. Circadian orchestration of developmental hormones in the insect, *Rhodnius prolix*. *Comp. Biochem. Phys., Part A* 144, 351-364.

Tu, M.-P., Yin, C.-M., Tatar, M., 2002. Impaired ovarian ecdysone synthesis of *Drosophila melanogaster* insulin receptor mutants. *Aging Cell* 1, 158-160.

Vafopoulou, X., Cardinal-Aucoin, M., Steel, C.G.H., 2012. Rhythmic release of prothoracicotrophic hormone from the brain of an adult insect during egg development. *Comp. Physiol. Biochem. Part A* 161, 193-200.

Vafopoulou, X., Steel, C.G.H., 1989. Developmental and diurnal changes in ecdysteroid biosynthesis by prothoracic glands of *Rhodnius prolixus* (Hemiptera) *in vitro* during the last larval instar. *Gen. Comp. Endocrinol.* 74, 484–493.

Vafopoulou, X., Steel, C.G.H., 1991. Circadian regulation of synthesis of ecdysteroids by prothoracic glands of the insect *Rhodnius prolixus*: Evidence of a dual oscillator system. *Gen. Comp. Endocrinol.* 83, 27-34.

Vafopoulou, X., Steel, C.G.H., 1992. *In vitro* photosensitivity of ecdysteroid synthesis by prothoracic glands of *Rhodnius prolixus* (Hemiptera). *Gen. Comp. Endocrinol.* 86, 1-9.

Vafopoulou, X., Steel, C.G.H., 1993. Release *in vitro* of prothoracicotropic hormone from the brain of male *Rhodnius prolixus* during larval-adult development: Identification of novel and predicted release times. *J. Insect Physiol.* 39, 65-71.

Vafopoulou, X., Steel, C.G.H., 1996a. The insect neuropeptide prothoracicotropic hormone is released with a daily rhythm: Re-evaluation of its role in development. *Proc. Natl. Acad. Sci. USA* 93, 3368-3372.

Vafopoulou, X., Steel, C.G.H., 1996b. Circadian regulation of a daily rhythm of release of prothoracicotropic hormone from the brain-retrocerebral complex of *Rhodnius prolixus* (Hemiptera) during larval-adult development. *Gen. Comp. Endocrinol.* 102, 123-129.

Vafopoulou, X., Steel, C.G.H., 1998. A photosensitive circadian oscillator in an insect endocrine gland: photic induction of rhythmic steroidogenesis *in vitro*. *J. Comp. Physiol.* A 182, 343-349.

Vafopoulou, X., Steel, C.G.H., 2001. Induction of rhythmicity in prothoracicotropic hormone and ecdysteroids in *Rhodnius prolixus*: roles of photic and neuroendocrine Zeitgebers. *J. Insect Physiol.* 47, 935-941.

Vafopoulou, X., Steel, C.G.H., 2002. Prothoracicotrophic hormone of *Rhodnius prolixus*: partial characterization and rhythmic release of neuropeptides related to *Bombyx* PTTH and bombyxin. *Invert. Reprod. Devel.* 42, 111-120.

Vafopoulou, X., Steel, C.G.H., 2012. Metamorphosis of a Clock: Remodelling of the Circadian Timing System in the Brain of *Rhodnius prolixus* (Hemiptera) During Larval-Adult Development. *J. Comp. Neurol.* 520, 1146-1164.

Vafopoulou, X., Steel, C.G.H., Terry, K.L., 2007. Neuroanatomical relations of prothoracicotrophic hormone neurons with the circadian timekeeping system in the brain of larval and adult *Rhodnius prolixus* (Hemiptera). *J. Comp. Neur.* 503, 511-524.

Vafopoulou, X., Steel, C.G.H., 2014. Synergistic induction of the clock protein PERIOD by insulin-like peptide and prothoracicotrophic hormone in *Rhodnius prolixus* (Hemiptera): implications for convergence of hormone signaling pathways. *Front. Physiol.* doi: 10.3389/fphys.2014.00041.

Vafopoulou, X., Terry, K.L., Steel, C.G.H., 2010. The circadian timing system in the brain of the fifth larval instar of *Rhodnius prolixus* (Hemiptera). *J. Comp. Neurol.* 518, 1264-1282.

Warren, J.T., Bachman, J.S., Dai, J., Gilbert, L.I., 1996. Differential incorporation of cholesterol and cholesterol derivatives into ecdysteroids by the larval ring glands and adult ovaries of *Drosophila melanogaster*: a putative explanation for the *l(3)ecd^l* mutation. *Insect Biochem. Mol. Biol.* 26, 931-943.

Wigglesworth, V.B., 1934. The physiology of ecdysis in *Rhodnius prolixus* (Hemiptera) II. Factors controlling molting and “metamorphosis”. *Quart. J. Mic. Sci.* 77, 191-222.

Wigglesworth, V.B., 1940. The determination of characters at metamorphosis in *Rhodnius prolixus* (Hemiptera). *J. Exp. Biol.* 17, 201-222.

Wigglesworth, V.B., 1955. The breakdown of the thoracic gland in the adult insect *Rhodnius prolixus*. *J. Exp. Biol.* 32,485-491.

Williams, C.M., Adkisson, P.L., 1964. Physiology of insect diapause. XIV. An endocrine mechanism for the photoperiodic control of pupal diapause in the oak silkworm *Antheraea pernyi*. *Biol. Bull.* 127, 511–525.

Wu, Q., Brown, M.R., 2006. Signaling and function of insulin-like peptides in insects. *Ann. Rev. Entomol.* 51, 1-24.

Závodská, R., Sauman, I., Sehnal, F. 2003. Distribution of PER protein, pigment-dispersing hormone, prothoracicotropic hormone, and eclosion hormone in the cephalic nervous system of insects. *J. Biol. Rhythms* 18, 106-122.

Zhang, Q., Denlinger, D.L., 2011. Molecular structure of the prothoracicotropic hormone gene in the northern house mosquito, *Culex pipiens*, and its expression analysis in association with diapause and blood feeding. *Insect Mol. Biol.* 20, 201-213.

3. Chapter 4

Ampleford, E.J., Davey, K.G., 1989. Egg laying in the insect *Rhodnius prolixus* is timed in a circadian fashion. *J. Insect Physiol.* 35, 183-187.

Ampleford, E.J., Steel, C.G.H. 1985. Circadian control of a daily rhythm in hemolymph ecdysteroid titer in the insect *Rhodnius prolixus* (Hemiptera). *Gen. Comp. Endocrinol.* 59, 453-459.

Bitsch, J., Rojo de la Paz, A., Mathelin, J., Delbecque, J.P., Delachambre, J., 1979
Recherche sur les ecdystéroïdes hémolympatiques et ovariens de *Thermobia domestica* (Insecta, Thysanura). *C. R. Acad. Sci. Paris* 289, 865-868.

Brown, M.R., Clark, K.D., Gulia, M., Zhao, Z., Garczynski, S.F., Crim, J.W., Suderman, R.J., Strand, M.R., 2008. An insulin-like peptide regulates egg maturation and metabolism in the mosquito *Aedes aegypti*. *Proc. Nat. Acad. Sci. USA* 105, 5716-5721.

Brown, M.R., Sieglaff, D.H., Rees, H.H., 2009. Gonadal ecdysteroidogenesis in arthropoda: occurrence and regulation. *Ann. Rev. Entomol.* 54, 105-125.

Bullière, D., Bullière, F., de Reggi, M., 1979. Ecdysteroid titres during ovarian and embryonic development in *Blaberus cranifer*. *Wilhelm Roux's Arch.* 186, 103-114.

Buxton, P. A., 1930. The biology of a blood-sucking bug, *Rhodnius prolixus*. *Trans. R. Ent. Soc. Lond.* 78, 227-236.

Chen, A.C., Kelly, T.J., 1993. Correlation of ecdysteroids with ovarian development and yolk protein synthesis in the adult stable fly, *Stomoxys calcitrans*. *Comp. Biochem. Physiol.* 104A, 485-490.

Delbecque, J.P., Weidner, K., Hoffmann, K.H., 1990. Alternative sites for ecdysteroid production in insects. *Invert. Reprod. Dev.* 18, 29-42.

Dinan, L., 1997. Ecdysteroids in adults and eggs of the house cricket, *Acheta domestica* (Orthoptera: Gryllidae). *Comp. Biochem. Physiol. B* 116, 129-135.

Fahrenkrug, J., Georg, B., Hannibal, J., Hindersson, P., Gräs, S., 2006. Diurnal rhythmicity of the clock Genes *Per1* and *Per2* in the rat ovary. *Endocrinology* 147, 3769-3776.

Feldlaufer, M.F., Svoboda, J.A., Herbert, E.W.Jr., 1986. Makisterone A and 24-methylenecholesterol from the ovaries of the honey bee, *Apis mellifera* L. *Experientia* 42, 200-201.

Friend, W.G., Choy, C.T.H., Cartwright, E., 1965. The effect of nutrient intake on the development and egg production of *Rhodnius prolixus* (Hemiptera: Reduviidae). *J. Can. Zool.* 43, 891-904.

Gilbert, L.I., Goodman, W., W.E. Bollenbacher, W.E., 1977. Biochemistry of regulatory lipids and sterols in insects. *Int. Rev. Biochem.* 14,1-50.

Goltzené, F., Lagueux, M., Charlet, M., Hoffmann, J.A., 1978. The follicle cell epithelium of maturing ovaries of *Locusta migratoria*: a new biosynthetic tissue for ecdysone. *Hoppe Seylers Z. Physiol. Chem.* 359,1427–1434.

Graf, R., Neuenschwander, S., Brown, M.R., Ackermann, U., 1997. Insulin-mediated secretion of ecdysteroids from mosquito ovaries and molecular cloning of the insulin

receptor homologue from ovaries of bloodfed *Aedes aegypti*. *Insect Mol. Biol.* 6, 151-163.

Gringorten, J.L., Friend, W.G., 1979. Haemolymph volume changes in *Rhodnius prolixus* during flight. *J. Exp. Biol.* 83, 325-333.

Hagedorn, H.H., 1985. The role of ecdysteroids in reproduction. In: Kerkut, G.A., L.I. Gilbert (Eds.), *Comprehensive Insect Physiology, Biochemistry, and Pharmacology*, vol. 8. Pergamon Press Ltd., Oxford, England, pp. 205-262.

Hagedorn, H.H., O'Connor, J.D., Fuchs, M.S., Sage, B., Schlaeger, D.A., Bohm, M.K., 1975. The ovary as a source of α -ecdysone in an adult mosquito. *Proc. Nat. Acad. Sci. USA* 72, 3255-3259.

Hardin, P.E., 1994. Analysis of period mRNA cycling in *Drosophila* head and body tissues indicates that body oscillators behave differently from head oscillators. *Mol. Cell. Biol.* 14, 7211-7218.

Hastings, M., O'Neill, J.S., Maywood, E.S., 2007. Circadian clocks: regulators of endocrine and metabolic rhythms. *J. Endocrinol.* 195, 187-198.

Haus, E. 2007. Chronobiology in the endocrine system. *Adv. Drug Delivery Rev.* 59, 985-1014.

He, P.-J., Hirata, M., Yamauchi, N., Hashimoto, S., Hattori, M.-a., 2007. Gonadotropic regulation of circadian clockwork in rat granulosa cells. *Mol. Cell. Biochem.* 302, 111-118.

Hoffmann, K.H., Weidner, K. Seidel, M., 1992. Sites of ecdysteroid biosynthesis in female adults of *Gryllus bimaculatus* (Ensifera, Gryllidae). *J. Comp. Physiol. B.* 162, 731-739.

Horn, D.H.S., Wilkie, J.S., Sage, B.A., O'Connor, J.D., 1976. A high affinity antiserum specific for the ecdysone nucleus. *J. Insect Physiol.* 22, 901-905.

Huebner, E., Anderson, E., 1972. A cytological study of the ovary of *Rhodnius prolixus*, II. Oocyte differentiation. *J. Morph.* 137, 385-416.

Ito, Y., Yasuda, A., Sonobe, H. 2008. Synthesis and phosphorylation of ecdysteroids during ovarian development in the silkworm, *Bombyx mori*. *Zool. Sci.* 25, 721-727.

Johnson, C. H., Elliott, J., Foster, R., Honma, K., Kronauer, R.E., 2004. Fundamental properties of circadian rhythms. In Dunlap, J., Loros, J., DeCoursey, P.J. (Eds.) *Chronobiology*, Sinauer Associates, Sunderland, MA, pp. 67–105.

Karman, B.N., Tischkau, S.A., 2006. Circadian clock gene expression in the ovary: effects of luteinizing hormone. *Biol. Reprod.* 75, 624-632.

Kotwica, J., Larson, M., Bebas, P., J.M. Giebultowicz, J.M., 2009. Developmental profiles of PERIOD and DOUBLETIME in *Drosophila melanogaster*. *J. Insect Physiol.* 55, 419-425.

Kruskal, W.H., Wallis, W.A., 1952. The use of ranks in one-criterion variance analysis. *J. Am. statist. Ass.* 47, 583-621.

Lagueux, M., Harry, P., Hoffman, J.A., 1981. Ecdysteroids are bound to vitellin in newly laid eggs of *Locusta*. *Mol. Cell. Endocrinol.* 24, 325-338.

Lagueux, M., Hetru, C., Goltzene, F., Kappler, C., Hoffman, J.A., 1979. Ecdysone titre and metabolism in relation to cuticulogenesis in embryos of *Locusta migratoria*. *J. Insect Physiol.* 25, 709-723.

Lagueux, M., Hirn, M., Hoffmann, J.A., 1977. Ecdysone during development in *Locusta migratoria*. J. Insect Physiol. 23, 109-120.

Lane, N.J., Leslie, R.A., Swales, L.S., 1975. Insect peripheral nerves: accessibility of neurohaemal regions to lanthanum. J. Cell. Sci. 18, 179-197.

Loeb, M.J., Brandt, E.P., Birnbaum, J.M., 1984. Ecdysteroid production by testes of the tobacco budworm *Heliothis virescens* from last larval instar to adult. J. Insect Physiol. 30, 375-381.

Maddrell, S.H.P., Gardiner, B.O.C., 1980. The retention of amino acids in the hemolymph during diuresis in *Rhodnius*. J. Exp. Biol. 87, 315-329.

Manière, G., Rondot, I., Büllsbach, E.E., Gautron, F., Vanhems, E., Delbecque, J.P., 2004. Control of ovarian steroidogenesis by insulin-like peptides in the blowfly (*Phormia regina*). J. Endocrinol. 181, 147-156.

Ono, H., Rewitz, K.F., Shinoda, T., Itoyama, K., Petryk, A., Rybczynski, R., Jarcho, M., Warren, J.T., Marqués, G., Shimell, M.J., Gilbert, L.I., O'Connor, M.B. 2006. *spook* and *spookier* code for stage-specific components of the ecdysone biosynthetic pathway in Diptera. Dev. Biol. 298, 555-570.

Pascual, N., Cerda, X., Benito, B., Tomas, J., Piulachs, M.D., Belles, X., 1992. Ovarian ecdysteroid levels and basal oocyte development during maturation in the cockroach *Blattella germanica* (L.). *J. Insect Physiol.* 38, 339-348.

Pelc D., Steel C.G.H., 1997. Rhythmic steroidogenesis by the prothoracic glands of the insect, *Rhodnius prolixus*, in the absence of rhythmic neuropeptide input: Implications for the role of prothoracicotrophic hormone. *Gen. Comp. Endocrinol.* 108, 358-365.

Polanska, M.A., Maksimiuk-Ramirez, E., Ciuk, M.A., Kotwica, J., Bebas, P., 2009. Clock- controlled rhythm of ecdysteroid levels in the haemolymph and testes, and its relation to sperm release in the Egyptian cotton leafworm, *Spodoptera littoralis*. *J. Insect Physiol.* 55, 426-434.

Pratt, G.E., Davey, K.G., 1972. The corpus allatum and oogenesis in *Rhodnius prolixus* (Stal). *J. Exp. Biol.* 56, 201-214.

Raihkel, A.S., Brown, M.R., Belles, X., 2005. Hormonal control of reproductive processes. In: Gilbert, L. I., Iatrou, K., Gill, S.G. (Eds.), *Comprehensive Molecular Insect Science*, vol. 3. Elsevier, Oxford, pp. 433-491.

Richard, D.S., Rybczynski, R., Wilson, T.G., Wang, Y., Wayne, M.L., Zhou, Y., Partridge, L., Harshman, L.G., 2005. Insulin signaling is necessary for vitellogenesis in

Drosophila melanogaster independent of the roles of juvenile hormone and ecdysteroids: female sterility of the chico1 insulin signaling mutation is autonomous to the ovary. J. Insect. Physiol. 51, 455-464.

Riehle, M.A., Brown, M.R., 1999. Insulin stimulates ecdysteroid production through a conserved signaling cascade in the mosquito *Aedes aegypti*. Insect Biochem. Mol. Biol. 29, 855-860.

Rubbenstein, E.C., Kelly, T.J., Schwartz, M.B., Woods, C.W., 1982. In vitro synthesis and secretion of ecdysteroids by *Drosophila melanogaster* ovaries. J. Exp. Zool. 223, 305-308.

Ruegg, R.P., Kriger, F.L., Davey, K.G., Steel, C.G.H., 1981. Ovarian ecdysone elicits release of a myotropic ovulation hormone in *Rhodnius* (Insecta: Hemiptera). Internat. J. Invert. Reprod. 3, 357-361.

Saez, L., Young, M.W., 1988. *In Situ* localization of the per clock protein during development of *Drosophila melanogaster*. Mol. Cell. Biol. 8, 5378-5385.

Sall, C., Tsoupras, G., Kappler, C., Lagueux, M., Zachary, D., Luu, B., Hoffmann, J.A., 1983. Fate of maternal conjugated ecdysteroids during embryonic development in *Locusta migratoria*. J. Insect Physiol. 29, 491-507.

Sellix, M.T., Menaker, M., 2010. Circadian clocks in the ovary. *Trends Endocrinol. Metab.* 28, 628-636.

Sonobe, H., Yamada, R., 2004. Ecdysteroids during early embryonic development in silkworm *Bombyx mori*: metabolism and functions. *Zool. Sci.* 21, 503-516.

Stay, B., Ostedgaard, L.S., Tobe, S.S., Strambi, A., Spaziani, A., 1984. Ovarian and haemolymph titres of ecdysteroid during the gonadotrophic cycle in *Diptera punctata*. *J. Insect Physiol.* 30, 643-651.

Steel, C.G.H. and Ampleford, E.J. (1984) Circadian control of haemolymph ecdysteroid titres and the ecdysis rhythm in *Rhodnius prolixus*. In: R. Porter and G.M. Collins (Eds.), *Photoperiodic Regulation of Insect and Molluscan Hormones*, Ciba Foundation Symposium, no. 104, pp. 150-169, Pitman, London.

Steel, C.G.H., Bollenbacher, W E., Smith, S.L., Gilbert, L.I., 1982. Haemolymph ecdysteroid titres during larval-adult development in *Rhodnius prolixus*: correlations with moulting hormone action and brain neurosecretory cell activity. *J. Insect Physiol.* 28, 519-525.

Steel, C.G.H., Vafopoulou, X., 2006. Circadian orchestration of developmental hormones in the insect, *Rhodnius prolixus*. *Comp. Biochem. Phys., Part A* 144, 351-364.

Swevers, L., Iatrou, L., 2009. Ecdysteroids and Ecdysteroid Signaling Pathways During Insect Oogenesis. In Smagghe, G. (Ed.), *Ecdysone: Structures and Functions*, Springer Science + Business Media B.V., pp. 127-164.

Tawfik, A.I., Vedrová, A., Sehnal, F., 1999. Ecdysteroids during ovarian development and embryogenesis in solitary and gregarious *Schistocerca gregaria*. *Arch. Insect Biochem. Physiol.* 41, 134-143.

Tischkau, S.A., Howell, R.E., Hickock, J.R., Krager, S.L., Bahr, J.M., 2011. The luteinizing hormone surge regulates circadian clock gene expression in the chicken ovary. *Chronobiol. Int.* 28, 10-20.

Vafopoulou, X., Cardinal-Aucoin, M., Steel, C.G.H., 2012. Rhythmic release of prothoracicotropic hormone from the brain of an adult insect during egg development. *Comp. Physiol. Biochem. Part A* 161, 193-200.

Vafopoulou, X., Steel, C.G.H., 1989. Developmental and diurnal changes in ecdysteroid biosynthesis by prothoracic glands of *Rhodnius prolixus* (Hemiptera) *in vitro* during the last larval instar. *Gen. Comp. Endocrinol.* 74, 484-493.

Vafopoulou, X., Steel, C.G.H., 1998. A photosensitive circadian oscillator in an insect endocrine gland: photic induction of rhythmic steroidogenesis in vitro. *J. Comp. Physiol. A* 182, 343-349.

Vafopoulou, X., Steel, C.G.H., 2005. Testis ecdysiotropic peptides in *Rhodnius prolixus*: Biological activity and distribution in the nervous system and testis. *J. Insect Physiol.* 51, 1227-1239.

Vafopoulou, X., Steel, C.G.H., 2009. Circadian organization of the endocrine system. In: Gilbert, L.I. (Ed.), *Insect Development: Morphogenesis, Molting and Metamorphosis*, Elsevier, New York, NY, pp. 395-458.

Vafopoulou, X., Steel, C.G.H., 2012. Insulin-like and testis ecdysiotropin neuropeptides are regulated by the circadian timing system in the brain during larval-adult development in the insect *Rhodnius prolixus* (Hemiptera). *Gen. Comp. Endocrinol.* 179, 277-288.

Weaver, R.J. Strambi, A., Strambi, C., 1984. The significance of free ecdysteroids in the haemolymph of adult cockroaches. *J. Insect Physiol.* 30, 705-711.

Wilps, H., Zöller, T., 1989. Origin of ecdysteroids in females of the blowfly *Phormia terranova* and their relation to reproduction and energy metabolism. *J. Insect Physiol.* 35, 709-717.

Yamazaki, Y., Kiuchi, M., Takeuchi, H., Kubo, T., 2011. Ecdysteroid biosynthesis in workers of the European honeybee *Apis mellifera* L. *Insect Biochem. Mol. Biol.* 41, 283-293.

Zhu, X.X., Gfeller, H., Lanzrein, B., 1983. Ecdysteroids during oogenesis in the ovoviviparous cockroach *Nauphoeta cinerea*. *J. Insect Physiol.* 29, 225-235.

4. General References

Abdelsalam, S., Hiroyuki, U., Umezaki, Y., Saifullah, A.S.M., Shimohigashi, M., Tomioka, K., 2008. Characterization of PDF-immunoreactive neurons in the optic lobe and cerebral lobe of the cricket, *Gryllus bimaculatus*. *J. Insect Physiol.* 54, 1205-1212.

Abdou, M.A., Heb, Q., Wen, D., Zyaan, O., Wang, J., Xu, J., Baumann, A.A., Joseph, J., Wilson, T.J., Li, S., Wang, J., 2011. *Drosophila* Met and Gce are partially redundant in transducing juvenile hormone action. *Insect Biochem. Mol. Biol.*, 41, 938-945.

Abe, K., Kroning, J., Greer, M.A., Critchlow, V., 1979. Effects of destruction of the suprachiasmatic nuclei on the circadian rhythms in plasma corticosterone, body temperature, feeding and plasma thyrotropin. *Neuroendocrinology* 29, 119-131.

Abe, Y., Ushirogawa, H., Tomioka, K., 1997. Circadian locomotor rhythms in the cricket, *Gryllobates sigillatus*. I. Localization of the pacemaker and the photoreceptor. *Zoolog. Sci.* 14, 719-727.

Abrahamson, E.E., Moore, R.Y., 2001. Suprachiasmatic nucleus in the mouse: retinal innervation, intrinsic organization and efferent projections. *Brain Res.* 916, 172-191.

Agez, L., Laurent, V., Guerrero, H.Y., Pévet, P., Masson- Pévet, M., Gauer, F., 2009. Endogenous melatonin provides an effective circadian message to both the suprachiasmatic nuclei and the pars tuberalis of the rat. *J. Pineal Res.* 46, 95-105.

Agui, N., Granger, N.A., Bollenbacher, W.E, Gilbert, L.I., 1979. Cellular localization of the insect prothoracicotropic hormone: *In vitro* assay of a single neurosecretory cell. *Proc. Natl Acad. Sci. USA* 76, 5694-5698.

Agui, N., Bollenbacher, W.E., Granger, N.A., Gilbert, L.I., 1980. Corpus allatum is release site for insect prothoracicotropic hormone. *Nature* 285, 669-670.

Agui, N., Bollenbacher, W.E., Gilbert, L.I., 1983. *In vitro* analysis of prothoracicotropic hormone specificity and prothoracic gland sensitivity in Lepidoptera. *Experientia* 39, 984-988.

Ahima, R., Krozowski, Z., Harlan, R., 1991. Type I corticosteroid receptor-like immunoreactivity in the rat CNS: distribution and regulation by corticosteroids. *J. Comp. Neurol.* 313, 522-38.

Ahima, R.S., Harlan, R.E., 1990. Charting of type II glucocorticoid receptor-like immunoreactivity in the rat central nervous system. *Neuroscience* 39, 579-604.

Aida, R., Moriya, T., Araki, M., Akiyama, M., Wada, K., Wada, E., Shibata, S., 2002. Gastrin-releasing peptide mediates photic entrainable signals to dorsal subsets of suprachiasmatic nucleus via induction of *period* gene in mice. *Mol. Pharmacol.* 61, 26-34.

Albrecht, U., Sun, Z.S., Eichele, G., Lee, C.C., 1997. A differential response of two putative mammalian circadian regulators, *mper1* and *mper2*, to light. *Cell* 91, 1055-1064.

Albus, H., Vansteensel, M.J., Michel, S., Block, G.D., Meijer, J.H., 2005. A GABAergic mechanism is necessary for coupling dissociable ventral and dorsal regional oscillators within the circadian clock. *Curr. Biol.* 15, 886-893.

Allada, R., White, N.E., So, W.V., Hall, J.C., Rosbash, M., 1998. A mutant *Drosophila* homolog of mammalian Clock disrupts circadian rhythms and transcription of period and timeless. *Cell* 93, 791-804.

Alvarez-Saavedra, M., Antoun, G., Yanagiya, A., Oliva-Hernandez, R., Cornejo-Palma, D., Perez-Iratxeta, Sonenberg, N., Cheng, H.-Y., 2011. miRNA-132 orchestrates chromatin remodeling and translational control of the circadian clock. *Hum. Mol. Genet.* 20, 731-751.

Amir, S., Lamont, E.W., Robinson, B., Stewart, J., 2004. A circadian rhythm in the expression of PERIOD2 protein reveals a novel SCN controlled oscillator in the oval nucleus of the bed nucleus of the stria terminalis. *J Neurosci.* 24, 781-790.

Ampleford, E.J., Davey, K.G., 1989. Egg laying in the insect *Rhodnius prolixus* is timed in a circadian fashion. *J. Insect Physiol.* 35, 183-187.

Ampleford, E.J., Steel, C.G.H., 1985. Circadian control of a daily rhythm in hemolymph ecdysteroid titer in the insect *Rhodnius prolixus* (Hemiptera). *Gen. Comp Endocrinol.* 59, 453-459.

Andrews, R.V., 1971. Circadian rhythms in adrenal organ cultures. *Geg. Morpho. Jahr.* 117, 89-98.

Andrews, R.V., Folk Jr., G.E., 1964. Circadian metabolic patterns in cultured hamster adrenal glands. *Comp. Biochem. Physiol.* 11, 393-409.

Ariens Kappers, J., 1993. Innervation of the vertebrate pineal gland. In: Axelrod, J., Fraschini, F., Velo, G.P. (Eds.), *The Pineal Gland and Its Endocrine Role*, Plenum, New York, pp. 87-107.

Arjona, A., Silver, A.C., Walker, W.E., Fikrig, E., 2012. Immunity's fourth dimension: approaching the circadian-immune connection. *Trends Immunol.* 33, 607-612.

Aronson, B.D., Johnson, K.A., Loros, J.J., Dunlap, J.C., 1994. Negative feedback defining a circadian clock: autoregulation of the clock gene frequency. *Science* 263, 1578-1584.

Aschoff, J., 1979. Circadian rhythms: general features and endocrinological aspects. In: Krieger, D. (Ed.), *Endocrine Rhythms*, Raven Press, New York, pp 1-63.

Aschoff, J., Tokura, H., 1986. Circadian activity rhythms in squirrel monkeys: entrainment by temperature cycles. *J. Biol. Rhythms* 1, 91-99.

Badisco, L., Marchal, E., Van Wielendaele, P., Verlinden, H., Vleugels, R., Vanden Broeck, J., 2011. RNA interference of insulin-related peptide and neuroparsins affects vitellogenesis in the desert locust *Schistocerca gregaria*. *Peptides* 32, 573-580.

Badisco, L., Van Wielendaele, P., Vanden Broeck, J., 2013. Eat to reproduce: a key role for the insulin signaling pathway in adult insects. *Front. Physiol.* doi: 10.3389/fphys.2013.00202.

Bae, K., Edery, I., 2006. Regulating a circadian clock's period, phase and amplitude by phosphorylation: insight from *Drosophila*. *J. Biochem.* 140, 609-617.

Baker, C.L., Loros, J.J., Dunlap, J.C., 2012. The circadian clock of *Neurospora crassa*. *FEMS Microbiol. Rev.* 36, 95-110.

Balsalobre, A., 2002. Clock genes in mammalian peripheral tissues. *Cell Tissue Res.* 309, 193-199.

Balsalobre, A., Brown, S.A., Marcacci, L., Tronche, F., Kellendonk, C., Reichardt, H.M., Schultz, G., Schibler, U., 2000. Resetting of Circadian Time in Peripheral Tissues by Glucocorticoid Signaling. *Science* 289, 2344-2347.

Balsalobre, A., Damiola, F., Schibler, U., 1998. A serum shock induces circadian gene expression in mammalian tissue culture cells. *Cell* 93, 929-937.

Bargiello, T.A., Jackson, F.R., Young, M.W., 1984. Restoration of circadian behavioural rhythms by gene transfer in *Drosophila*. *Nature* 312, 752-754.

Bartness, T.J., Song, C.K., Demas, G.E., 2001. SCN efferents to peripheral tissues: implications for biological rhythms. *J. Biol. Rhythms* 16, 196-204.

Beaver, L.M., Rush, B.L., Gvakharia, B.O., Giebultowicz, J.M., 2003. Noncircadian regulation and function of clock genes period and timeless in oogenesis of *Drosophila melanogaster*. *J. Biol. Rhythms* 18, 463-72.

Bebas, P., Cymborowski, B., Giebultowicz, J.M., 2001. Circadian rhythm of sperm release in males of the cotton leafworm, *Spodoptera littoralis*: *in vivo* and *in vitro* studies. *J. Insect Physiol.* 47, 859-866.

Bellés, X., Maestro, J.L., 2005. Endocrine peptides and insect reproduction. *Invert. Reprod. Devel.* 47, 23-37.

Bell-Pedersen, D., Cassone, V.M., Earnest, D.J., Golden, S.S., Hardin, P.E., Thomas, T.L., Zoran, M.J., 2005. Circadian rhythms from multiple oscillators: lessons from diverse organisms. *Nat Rev Genet* 6, 544-556.

Berson, D.M., Dunn, F.A., Takao, M., 2002. Phototransduction by retinal ganglion cells that set the circadian clock. *Science* 295, 1070-1073.

Berthoud, V.M., Hall, D.H., Strahsburger, E., Beyer, E.C., Saez, J.C., 2000. Gap junctions in the chicken pineal gland. *Brain Res.* 861, 257-270.

Bidmon, H.J., Stumpf, W.E., Granger, N.A., 1992. Ecdysteroid receptors in the neuroendocrine axis of a moth. *Experientia* 48, 42-47.

Binkley, S., Kluth, E., Menaker, M. 1971. Pineal function in sparrows: circadian rhythms and body temperature. *Science* 174, 311-314.

Binkley, S., Reilly, K.B., Hryshchyshyn, H., 1980. *N*-Acetyltransferase in the chick retina. I. Circadian rhythms controlled by environmental lighting are similar to those in the pineal gland. *J. Comp. Physiol.* 139, 103-108.

Bitra, K., Palli, S.R., 2009. Interaction of proteins involved in ecdysone and juvenile hormone signal transduction. *Arch. Insect Biochem. Physiol.* 70, 90-105.

Bittman, E.L., Doherty, L., Huang, L., Paroskie, A., 2003. Period gene expression in mouse endocrine tissues. *Am. J. Physiol.-Reg. I* 285, R561-R569.

Bloch, G., Hazan, E., Rafaeli, A., 2013a. Circadian rhythms and endocrine functions in adult insects. *J. Insect Physiol.* 59, 56-59.

Bloch, G., Herzog, E.D., Levine, J.D., Schwartz, W.J., 2013b. Socially synchronized clocks. *Proc. R. Soc. B* 280, 20130035.

Block, G.D., McMahon, D. G., 1984. Cellular analysis of the *Bulla* ocular circadian pacemaker system. III. Localization of the circadian pacemaker. *J. Comp. Physiol.* 155, 387-395.

Block, G.D., McMahon, D.G., Wallace, S.F., Friesen, W.O., 1984. Cellular analysis of the *Bulla* ocular circadian pacemaker system. I. A model for retinal organization. *J. Comp. Physiol.* 155, 365-378.

Block, G.D., Roberts, M.H., Lusska, L.E., 1986. Cellular analysis of ocular circadian pacemaker coupling in *Bulla*: role of efferent impulses in phase shifting. *J. Biol. Rhythms* 1, 199-217.

Block, G.D., Wallace, S.F., 1982. Localization of a circadian pacemaker in the eye of a mollusk, *Bulla*. *Science* 217, 155-157.

Boden, M.J., Varcoe, T.J., Kennaway, D.J., 2013. Circadian regulation of reproduction: From gamete to offspring. *Prog. Biophys. Mol. Biol.* 113, 387-397.

Boden, M.J., Kennaway, D.J., 2006. Circadian rhythms in reproduction. *Reprod.* 132, 379-392.

Bodenstein, D., 1938. Untersuchungen zum Metamorphose problem. II. Entwicklungsrelationen in verschmolzenen Puppenteilen. *Wilhelm Roux Archiv. Entw. Mech.* 137, 636-660.

Bodenstein, D., 1953. Studies on the humoral mechanisms in growth and metamorphosis of the cockroach *Periplaneta americana* II. The function of the prothoracic gland and the corpus cardiacum. *J. Exp. Zool.* 123, 413-433.

Bodenstein, C., Heiland, I., Schuster, S., 2012. Temperature compensation and entrainment in circadian rhythms. *Phys. Biol.* 9, 036011.

Borst, D.W., O'Connor, J.D., 1972. Arthropod molting hormone: radioimmune assay. *Science* 178, 418-419.

Bounhiol, J.J., 1938. Recherches expérimentales sur le déterminisme de la métamorphose chez les Lépidoptères. Bull. Biol. Suppl. 24, 1-199.

Bowers, W.S., Thomson, M.J., Uebel, E.C., 1965. Juvenile and gonadotropic hormone activity of 10,11-epoxyfarnesenic acid methyl ester. Life Sci. 4, 2323-2331.

Bradshaw, W.E., Zani, P.A., Holzapfel, C.M., 2004. Adaptation to temperate climates. Evolution 58, 1748-1762.

Brandes, C., Plautz, J. D., Stanewsky, R., Jamison, C. F., Straume, M., Wood, K. V., Kay, S.A., Hall, J.C., 1996. Novel features of *Drosophila period* transcription revealed by real-time luciferase reporting. Neuron 16, 687-692.

Brandstätter, R., Kumar, V., Abraham, U., Gwinner, E., 2000. Photoperiodic information acquired *in vivo* is retained *in vitro* by a circadian oscillator, the avian pineal gland. Proc. Natl Acad. Sci. USA 97, 12324-12328.

Brandstätter, R., Abraham, U., Albrecht, U., 2001. Initial demonstration of rhythmic *per* gene expression in the hypothalamus of a non-mammalian vertebrate, the house sparrow. Neuroreport 12, 1167-1170.

Brogiolo, W., Stocker, H., Ikeya, T., Rintelen, F., Fernandez, R., Hafen, E., 2001. An evolutionarily conserved function of the *Drosophila* insulin receptor and insulin-like peptides in growth control. *Curr. Biol.* 11, 213–21.

Brown, M.R., Clark, K.D., Gulia, M., Zhao, Z., Garczynski, S.F., Crim, J.W., Suderman, R.J., Strand, M.R., 2008. An insulin-like peptide regulates egg maturation and metabolism in the mosquito *Aedes aegypti*. *Proc. Nat. Acad. Sci. USA* 105, 5716-5721.

Brown, M.R., Graf, R., Swiderek, K.M., Fendley, D., Stracker, T.H., Champagne, D.E., Lea, A.O., 1998. Identification of a steroidogenic neurohormone in female mosquitoes. *J. Biol. Chem.* 273, 3967-3971.

Brown, M.R., Sieglaff, D.H., Rees, H.H., 2009. Gonadal ecdysteroidogenesis in arthropoda: occurrence and regulation. *Ann. Rev. Entomol.* 54, 105-125.

Brown, S.A., Kowalska, E., Dallman, R., 2012. Re(inventing) the circadian feedback loop. *Develop. Cell* 22, 477-487.

Buijs, R.M., Escobar, C., 2007. Corticosterone and activity: the long arms of the clock talk back. *Endocrinology* 148, 5162-5164.

- Buijs, R.M., Scheer, F.A., Kreier, F., Bos, N., Goncharuk, V.D., Kalsbeek, A., 2006. Organization of circadian functions: interaction with the body. *Prog. Brain Res.* 153, 341-360.
- Buijs, R.M., Wortel, J., Van Heerikhuize, J.J., Feenstra, M.G., Ter Horst, G.J., Romijn, H.J., Kalsbeek, A., 1999. Anatomical and functional demonstration of a multisynaptic suprachiasmatic nucleus adrenal (cortex) pathway. *Eur. J. Neurosci.* 11, 1535-1544.
- Bullière, D., Bullière, F., de Reggi, M., 1979. Ecdysteroid titres during ovarian and embryonic development in *Blaberus cranifer*. *Wilhelm Roux's Arch.* 186, 103-114.
- Bünning, E., 1936. Die endogene Tagesrhythmik als Grundlage der Photoperiodischen Reaktion. *B. Deut. Bot. Gesell.* 54, 590-607.
- Butenandt, A., Karlson, P., 1954. Ueber die Isoleirung eines Metamorphose-Hormons der Insekten in Kristallisierter Form. *Z. Naturf.* 9b, 389-391.
- Buxton, P.A., 1930. The biology of a blood-sucking bug, *Rhodnius prolixus*. *Trans R. Entomol. Soc. Lond.* 78, 227-236.
- Cahill, G.M., 1996. Circadian regulation of melatonin production in cultured zebrafish pineal and retina. *Brain Res.* 708, 177-181.

Cahill, G.M., 2002. Clock mechanisms in zebrafish. *Cell Tissue Res.* 309, 27-34.

Cajochen, C., Altanay-Ekici, S., Munch, M., Frey, S., Knoblauch, V., 2013. Evidence that the lunar cycle influences human sleep. *Current Biol.* 23, 1485-1488.

de Candolle, A.P., 1832. De l'influence de la lumière sur les végétaux. *Physiol Vég.* 4, 1069.

Cardinal-Aucoin, M., Rapp, N., Steel, C.G.H., 2013. Circadian regulation of hemolymph and ovarian ecdysteroids during egg development in the insect *Rhodnius prolixus* (Hemiptera). *Comp. Biochem. Physiol. A.*, 503-509.

Cardinal-Aucoin, M., Steel, C.G.H., in preparation a. Prothoracicotropic hormone in an adult insect: circadian regulation and induction of rhythmicity by light cues. *Gen. Comp. Endocrinol.*

Carrow, G., Calibrese, R.L., Williams, C.M., 1981. Spontaneous and evoked release of prothoracicotropin from multiple neurohemal organs of the tobacco hornworm. *Proc. Natl Acad. Sci. USA* 78, 5866-570.

Cascio, C.S., Shinsako, J., Dallman, M.F., 1987. The suprachiasmatic nuclei stimulate evening ACTH secretion in the rat. *Brain Res.* 423, 173-178.

Cassone, V.M., Menaker, M., 1984. Is the avian circadian system a neuroendocrine loop? *J. Exp. Biol.* 232, 539-549.

Cassone V.M., Moore, R.Y., 1987. Retinohypothalamic projections and suprachiasmatic nucleus of the house sparrow, *Passer domesticus*. *J. Comp. Neurol.* 266, 171-182.

Cassone, V.M., Brooks, D.S., Kelm, T.A., 1995. Comparative distribution of 2[¹²⁵I]iodomelatonin binding in the brains of diurnal birds: outgroup analysis with turtles. *Brain Behav. Evol.* 45, 241-256.

Ceriani, M.F., Darlington, T.K., Staknis, D., Mas, P., Petti, A.A., Weitz, C.J., Kay, S.A., 1999. Light dependent sequestration of TIMELESS by CRYPTOCHROME. *Science* 285, 553-556.

Cermakian, N., Whitmore, D., Foulkes, N.S., Sassone-Corsi, P., 2000. Asynchronous oscillations of two zebrafish CLOCK partners reveal differential clock control and function. *Proc. Natl. Acad. Sci. USA* 97, 4339-4344.

Chabot, C.C., Menaker, M., 1992. Effects of physiological cycles of infused melatonin on circadian rhythmicity in pigeons. *J. Comp. Physiol. A* 170, 615-622.

Charles, J.-P., Iwema, T., Epa, V.C., Takaki, K., Rynes, J., Jindra, M., 2011. Ligand-binding properties of a juvenile hormone receptor, Methoprene-tolerant. *Proc. Natl. Acad. Sci. USA* 108, 21128–21133.

Chatterjee, A., Tanoue, S., Houl, J.H., Hardin. P.E., 2010. Regulation of gustatory physiology and appetitive behavior by the *Drosophila* circadian clock. *Curr. Biol.* 20, 1-10.

Chen, R., D'Alessandro, M., Lee, C., 2013. miRNAs are required for generating a time delay critical for the circadian oscillator. *Current Biol.* 23, 1959-1968.

Chen, A.C., Kelly, T.J., 1993. Correlation of ecdysteroids with ovarian development and yolk protein synthesis in the adult stable fly, *Stomoxys calcitrans*. *Comp. Biochem. Physiol.* 104A, 485-490.

Cheng, H.-Y., Papp, J.W., Varlamova, O., Dziema, H., Russell, B., Curfman, J.P., Nakazawa, T., Shimizu, K., Okamura, H., Impey, S., Obrietan, K., 2007. microRNA modulation of circadian-clock period and entrainment. *Neuron* 54, 813-829.

Cheon, S., Park, N., Cho, S., Kim, K., 2013. Glucocorticoid-mediated Period2 induction delays the phase of circadian rhythm. *Nucleic Acids Res.* 41, 6161-6174.

Chu, G., Misawa, I., Chen, H., Yamauchi, N., Shigeyoshi, Y., Hashimoto, S., Hattori, M., 2012. Contribution of FSH and triiodothyronine to the development of circadian clocks during granulosa cell maturation. *Am. J. Physiol. Endocrinol. Metab.* 302, E645-E653.

Clarke, J.D., Coleman, G.J., 1986. Persistent meal-associated rhythms in SCN-lesioned rats. *Physiol. Behav.* 36, 105-113

Colwell, C.S., 2000. Rhythmic coupling among cells in the suprachiasmatic nucleus. *J. Neurobiol.* 43, 379-388.

Colwell, C.S., 2005. Bridging the gap: coupling single-cell oscillators in the suprachiasmatic nucleus. *Nat. Neurosci.* 8, 10-12.

Colwell, C.S., Michel, S., Itri, J., Rodriguez, W., Tam, J., Lelievre, V., Hu, Z., Liu, X., Waschek, J., 2003. Disrupted circadian rhythms in VIP- and PHI-deficient mice. *Am. J. Physiol.* 285, R939-R949.

Cornelius, G., Rensing, L., 1976. Daily rhythmic changes in Mg^{2+} -dependent ATPase activity in human red blood cell membranes *in vitro*. *Biochem. Biophys. Res. Commun.* 71, 1269-1272.

Crosthwaite, S.K., Dunlap, J.C., Loros, J.J., 1997. *Science* 276, 763. *Neurospora wc-1* and *wc-2*: transcription, photoresponses, and the origins of mechanisms of action, each specific to the regulation of a distinct circadian rhythmicity. *Science* 276, 763-769.

Cymborowski, B., Muszynska-Pytel, M., Porcheron, P., Cassier, P., 1991. Hemolymph ecdysteroid titres controlled by a circadian clock mechanism in larvae of the wax moth, *Galleria melonella*. *J. Insect Physiol.* 37, 35-40.

Cymborowski, B., Smietanko, A., Delbecq, J.P., 1989. Circadian modulation of ecdysteroid titer in *Galleria melonella* larvae. *Comp. Biochem. Physiol. A* 94, 431-438.

Cyran, S.A., Buchsbaum, A.M., Reddy, K.L., Lin, M.C., Glossop, N.R., Hardin, P.E., Young, M.W., Storti, R.V., Blau, J., 2003. *vriille*, *Pdp1*, and *dClock* form a second feedback loop in the *Drosophila* circadian clock. *Cell* 112, 329-341.

Dai, J.-D., Mizoguchi, A., Gilbert, L.I., 1994. Immunoreactivity of neurosecretory granules in the brain-retrocerebral complex of *Manduca sexta* to heterologous antibodies

against *Bombyx* prothoracicotropic hormone and bombyxin. *Invert. Reprod. Devel.* 26, 187-196.

Danks, H.V., 2005. How similar are daily and seasonal biological clocks? *J. Insect Physiol.* 51, 609-619.

Darwin, C., Darwin, F., 1880. *The Power of Movement in Plants*. NYU Press, NY, NY, pp. 368.

Davey, K.G., 1981. Hormonal control of vitellogenin uptake in *Rhodnius prolixus* Stål. *Amer. Zool.* 21, 701-705.

Davey, K.G., 2007. The interaction of feeding and mating in the hormonal control of egg production in *Rhodnius prolixus*. *J. Insect Physiol.* 53, 208-215.

DeCoursey, P.J., 1960. Phase control of activity in an rodent. *Cold Spring Harb. Symp. Quant. Biol.* 25,49-55.

DeCoursey, P.J., Walker, J.K., Smith, S.A., A circadian pacemaker in free-living chipmunks: essential for survival? *J. Comp. Physiol. A* 186, 169-180.

Delbecque, J.P., Weidner, K., Hoffmann, K.H., 1990. Alternative sites for ecdysteroid production in insects. *Invert. Reprod. Dev.* 18, 29-42.

de Paula, R.M., Lewis, Z.A., Greene, A.V. Seo, K.S., Morgan, L.W., Bennett, L., Gomer, R.H., Bell-Pedersen, D., 2006. Two circadian timing circuits in *Neurospora crassa* cells share components and regulate distinct rhythmic processes. *J. Biol. Rhythm* 21, 159-168.

De Velasco, B., Shen, J., Go, S., Hartenstein, V., 2004. Embryonic development of the *Drosophila* corpus cardiacum, a neuroendocrine gland with similarity to the vertebrate pituitary, is controlled by sine oculis and glass. *Devel. Biol.* 274, 280-294.

Dijkstra, I., Binnekade, R. & Tilders, F.J.H. (1996) Diurnal variation in resting levels of corticosterone is not mediated by variation in adrenal responsiveness to adrenocorticotropin but involves splanchnic nerve integrity. *Endocrinology* 137, 540-547.

Dinan, L., 1997. Ecdysteroids in adults and eggs of the house cricket, *Acheta domesticus* (Orthoptera: Gryllidae). *Comp. Biochem. Physiol. B* 116, 129-135.

Dickmeis, T., 2009. Glucocorticoids and the circadian clock. *J. Endocrinol.* 200, 3-22.

Dragovic, Z., Tan, Y., Görl, M., Roenneberg, T., Mellow, M., 2002. Light reception and circadian behavior in 'blind' and 'clock-less' mutants of *Neurospora crassa*. *EMBO J.* 21, 3643-3651.

Driessche, T.V., 1994. Circadian rhythms in three unicellular organisms, the peculiarities of the organisms, the evidence brought on rhythms and their specific practical problems. Outline of recent hypotheses. *Biol. Rhythm Res.* 25, 345-386.

Duhamel du Monceau, H.L.D., 1758. *La physique des arbres*. Guérin et DeLatour, Paris.

Dumser, J.B., 1980. The regulation of spermatogenesis in insects. *Annu. Rev. Ent.* 25, 341-369.

Dumser, J.B., Davey, K.G., 1974. Endocrinological and other factors influencing testis development in *Rhodnius prolixus*. *Can. J. Zool.* 52, 1011-1022.

Dunlap, J.C., Loros, J.J., 2006. How fungi keep time: circadian system in *Neurospora* and other fungi. *Current Op. Microbiol.* 9, 579-587.

Durgan, D.J., Young, M.E., 2010. The cardiomyocyte circadian clock: emerging roles in health and disease. *Circ. Res.* 106, 647-658.

Ebihara, S., Oshima, I., Yamada, H., Goto, M., Sato, K., 1987. Circadian organization in the pigeon. In: Hiroshige, T., Honma, K. (Eds.), *Comparative Aspects of Circadian Clocks*, Hokkaido University Press, Sapporo, Japan, pp. 84-94.

Eckel-Mahan, K., Sassone-Corsi, P., 2013. Metabolism and the circadian clock converge. *Physiol. Rev.* 93, 107-135.

Edgar, R.S., Green, E.W., Zhao, Y., van Ooijen, G., Olmedo, M., Qin, X., Xu, Y., Pan, M., Valekunia, U.K., Feeney, K.A., Maywood, E.S., Hastings, M.H., Baliga, N., Meroow, M., Millar, A.J., Johnson, C.H., Kyriacou, C.P., O'Neill, J.S., Reddy, A.B., 2012. Peroxiredoxins are conserved markers of circadian rhythms. *Nature* 485, 459-466.

Edmunds, L.N., 1988. *Cellular and Molecular Basis of Biological Clocks: Models and Mechanisms for Circadian Timekeeping*. Springer-Verlag, Berlin, pp. 497.

Eelderink-Chen, Z., Mazotta, G., Sturre, Bosman, J., Roenneberg, T., Meroow, M., 2010. A circadian clock in *Saccharomyces cerevisiae*. *Proc. Natl. Acad. Sci. USA* 107, 2043-2047.

Emery, I., Noveral, J.M., Jamison, C.F., Siwicky, K.K., 1997. Rhythms of *Drosophila period* gene expression in culture. *Proc. Natl. Acad. Sci. USA* 94, 4092-4096.

- Emery, P., Stanewsky, R., Hall, J.C., Rosbash, M., 2000. A unique circadian-rhythm photoreceptor. *Nature* 404, 456-457.
- Engeland, W.C., Arnhold, M.M., 2005. Neural circuitry in the regulation of adrenal corticosterone rhythmicity. *Endocrine*. 28, 325-32.
- Eskin, A., 1979. Identification and physiology of a circadian pacemaker. *Fed. Proc.* 38, 2570-2572.
- Eusebio, E.J., Moody, W.J., 1986. Calcium-dependent action potentials in the prothoracic glands of *Manduca sexta*. *J. Exp. Biol.* 126, 531-536.
- Ewer, J., Frisch, B., Hamblen-Coyle, M.J., Rosbash, M., Hall, J.C., 1992. Expression of the *period* clock gene within different cell types in the brain of *Drosophila* adults and mosaic analysis of these cells' influence on circadian behavioral rhythms. *J. Neurosci.* 12, 3321-3349.
- Fahrenkrug, J., Georg, B., Hannibal, J., Hindersson, P., Gräs, S., 2006. Diurnal rhythmicity of the clock Genes *Per1* and *Per2* in the rat ovary. *Endocrinology* 147, 3769-3776.

Fahrenkrug, J., Hannibal, J., Georg, B., 2008. Diurnal rhythmicity of the canonical clock genes *Per1*, *Per2* and *Bmal1* in the rat adrenal gland is unaltered after hypophysectomy. *J. Neuroendocrinol.* 20, 323-329.

Fahrenkrug, J., Georg, B., Hannibal, J., Jorgensen, H., Lovendahl, H., 2012. Altered rhythm of adrenal clock genes, *StAR* and serum corticosterone in *VIP* receptor 2-deficient mice. *J. Mol. Neurosci.* 48, 584-596.

Feillet, C.A., Ripperger, J.A., Magnone, M.C., Dulloo, A., Albrecht, U., Challet, E., 2006. Lack of food anticipation in *Per2* mutant mice. *Curr Biol.* 16, 2016-2022.

Friend, W.G., Choy, C.T.H., Cartwright, E., 1965. The effect of nutrient intake on the development and egg production of *Rhodnius prolixus* (Hemiptera: Reduviidae). *Can. J. Zool.* 43, 891-904.

Frisch, B., Hardin, P.E., Hamblen-Coyle, M.J., Rosbash, M., Hall, J.C., 1994. A promoterless *period* gene mediates behavioral rhythmicity and cyclical *per* expression in a restricted subset of the *Drosophila* nervous system. *Neuron* 12, 555-570.

Fujii, S., Krishnan, P., Hardin, P., Amrein, H., 2007. Nocturnal male sex drive in *Drosophila*. *Curr. Biol.* 17, 244-251.

Fukuda, S., 1940. Induction of pupation in silkworm by transplanting the prothoracic gland. *Proc. Imp. Acad. Tokyo* 16, 414-416.

Fukuda, Y., Okano, T., 2002. Circadian clock system in the pineal gland. *Mol. Neurobiol.* 25, 19-30.

Fullbright, G., Lacy, E.R., Bullesbach, E.E., 1997. The prothoracicotrophic hormone bombyxin has specific receptors on insect ovarian cells. 245, 774-780.

Furay, A.R., Murphy, E.K., Mattson, M.P., Guo, Z., Herman, J.P., 2006. Region specific regulation of glucocorticoid receptor/HSP90 expression and interaction in brain. *J. Neurochem.* 98, 1176-1184.

Ganguly, S., Coon, S.L., Klein, D.C., 2002. Control of melatonin synthesis in the mammalian pineal gland: the critical role of serotonin acetylation. *Cell Tissue Res.* 309, 127-137.

Gabe, M., 1953. Sur quelques applications de la coloration par la fuchsine-paraldehyde. *Bull. Mic. Appl.* 3, 153-162.

Gallego, M., Virshup, D.M., 2007. Post-translational modifications regulate the ticking of the circadian clock. *Nat. Rev. Mol. Cell Bio.* 8, 139-148.

Garceau, N.Y., Liu, Y., Loros, J.J., Dunlap, J.C., 1997. Alternative initiation of translation and time-specific phosphorylation yield multiple forms of the essential clock protein FREQUENCY. *Cell* 89, 469-476.

Garofolo, R.S., Rosen, O.M., 1988. Tissue localization of *Drosophila melanogaster* insulin receptor transcripts during development. *Mol. Cell. Biol.* 8, 1638-1647.

Gaston, S., Menaker, M., 1968. Pineal Function. The biological clock in the sparrow. *Science* 160, 1125.

Gatfield, D., Le Martelot, G., Vejnar, C.E., Gerlach, D., Schaad, O., Fleury-Olela, F., Ruskeepaa, A.-L., Oresic, M., Esau, C.C., Zdobnov, E.M., Schibler, E., 2009. Integration of microRNA miR-122 in hepatic circadian gene expression. *Genes Dev.* 23, 1313-1326.

Gegear, R.J., Casselman, A., Waddell, S., Reppert, S.M., 2008. Cryptochrome mediates light-dependent magnetosensitivity in *Drosophila*. *Nature* 454, 454.

Gibbs, J.E., Beesley, S., Plumb, J., Singh, D., Farrow, S., Ray, D.W., Loudon, A.S.I., 2009. Circadian timing in the lung; a specific role of bronchiolar epithelial cells. *Endocrinology* 150, 268-276.

Giebultowicz, J.M., 2001. Peripheral clocks and their role in circadian timing: insights from insects. *Philos. Trans. R. Soc. Lond. B* 356, 1791-1799.

Giebultowicz, J.M., 1999. Insect circadian clocks: is it all in their heads? *J. Insect Physiol.* 45, 791-800.

Giebultowicz, J.M., Hege, D.M., 1997. Circadian clock in Malpighian tubules. *Nature* 386, 664.

Giebultowicz, J.M., Riemann, J.G., Raina, A.K., Ridgway, R.L., 1989. Circadian system controlling release of sperm in the insect testes. *Science* 245, 1098-1100.

Giebultowicz, J.M., Stanewsky, R., Hall, J.C., Hege, D.M., 2000. Transplanted *Drosophila* excretory tubules maintain circadian clock cycling out of phase with the host. *Curr. Biol.* 10, 107-110.

Gilbert, L.I., 2004. Halloween genes encode P450 enzymes that mediate steroid hormone biosynthesis in *Drosophila melanogaster*. *Mol. Cell. Endocrinol.* 215, 1-10.

Gilbert, L.I., Granger, N.A., Roe, R.M., 2000. The juvenile hormones: historical facts and speculations on future research directions. *Insect Biochem. Mol. Biol.* 30, 617-644.

Gilbert, L.I., Rybczynski, R., Warren, J.T., 2002. Control and biochemical nature of the ecdysteroidogenic pathway. *Ann. Rev. Entomol.* 47, 883-916.

Girotti, M., Weinberg, M.S., Spencer, R.L., 2009. Diurnal expression of functional and clock-related genes throughout the rat HPA axis: system-wide shifts in response to a restricted feeding schedule. *Am. J. Physiol. Endocrinol. Metab.* 296, E888-E897.

Glossop, N.R.J., 2011. Circadian timekeeping in *Drosophila melanogaster* and *Mus musculus*. *Essays Biochem.* 49, 19-35.

Glossop, N.R.J., Hardin, P.E., 2002. Central and peripheral circadian oscillator mechanisms in flies and mammals. *J. Cell Sci.* 115, 3369-3377.

Goldman, B.D., 2001. Mammalian photoperiodic system: formal properties and neuroendocrine mechanisms of photoperiodic time measurement. *J. Biol. Rhythms* 16, 283-301.

Goltzené, F., Lagueux, M., Charlet, M., Hoffmann, J.A., 1978. The follicle cell epithelium of maturing ovaries of *Locusta migratoria*: a new biosynthetic tissue for ecdysone. *Hoppe Seylers Z Physiol. Chem.* 359,1427–1434.

Goodman, W.G., Granger, N.A., 2009. The juvenile hormones. In: Gilbert, L.I. (Ed.), *Insect Development: Morphogenesis, Molting and Metamorphosis*, Elsevier, New York, pp. 305-394.

Goodspeed, D., Chehab, E.W., Min-Venditti, A., Braam, J., Covington, M.F., 2012. *Arabidopsis* synchronizes jasmonate-mediated defense with insect circadian behavior. *Proc. Natl. Acad. Sci, USA* 109, 4674-4677.

Gorbet, D.J., Steel, C.G.H., 2003. A miniature radioimmunoassay for melatonin for use with small samples from invertebrates. *Gen. Comp. Endocrinol.* 134, 193-197.

Graf, R., Neuenschwander, S., Brown, M.R., Ackermann, U., 1997. Insulin-mediated secretion of ecdysteroids from mosquito ovaries and molecular cloning of the insulin receptor homologue from ovaries of bloodfed *Aedes aegypti*. *Insect Mol. Biol.* 6, 151-163.

Granger, N.A., Sturgis, S.L., Ebersohl, R., Geng, C.X., Sparks, T.S., 1996. Dopaminergic control of corpora allata activity in the larval tobacco hornworm, *Manduca sexta*. *Arch. Insect. Biochem. Physiol.* 32, 449-466.

Gu, S.H., 2007. Autocrine activation of ecdysteroidogenesis in the prothoracic glands of the silkworm, *Bombyx mori*. *J. Insect Physiol.* 53, 538-549.

Gu, S.H., Lin, J.L., Lin, P.L., Chen, C.H., 2009. Insulin stimulates ecdysone secretion by prothoracic glands in the silkworm, *Bombyx mori*. *Insect Biochem. Mol. Biol.* 39, 171-179.

Gwinner, E., 1966. Entrainment of a circadian rhythm in birds by species-specific song cycles (Aves, Fringillidae: *Carduelis spinus*, *Serinus serinus*). *Experientia* 22,1-3.

Gwinner, E., Benzinger, I., 1978. Synchronization of a circadian rhythm in pinealectomized European starlings by daily injections of melatonin. *J. Comp. Physiol. A* 126, 123-129.

Hachlow, V., 1931. Zur Entwicklungsmechanik der Schmetterlinge. *Wilhelm Roux Archiv. Entw. Mech.* 125, 26-49.

Hadden, H., Soldin, S.J., Massaro, D., 2012. Circadian disruption alters mouse lung clock gene expression and lung mechanics. *J. Appl. Physiol.* 113, 385-392.

Hagedorn, H.H., 1985. The role of ecdysteroids in reproduction. In: Kerkut, G. A. Gilbert, L. I. (Eds.), *Comprehensive Insect Physiology, Biochemistry, and Pharmacology*, vol. 8. Pergamon, Oxford, England, pp. 205-262.

Halberg, F., 1959. Physiologic 24-hour periodicity in human beings and mice, the lighting regimen and daily routine. In: Withrow, E. (ed.) Photoperiodism and related phenomena in plants and animals. AAAS, Washington, pp 803-878.

Hamada, T., LeSauter, J., Lokshin, M., Romero, M.-T., Yan, L., Venuti, J.M., Silver, R., 2003. Calbindin influences response to photic input in suprachiasmatic nucleus. *J. Neurosci.* 23, 8820-8826.

Handler, A.M., Konopka, R.J., 1979. Transplantation of a circadian pacemaker in *Drosophila*. *Nature* 279, 236-238.

Hannibal, J., 2002. Neurotransmitters of the retino-hypothalamic tract. *Cell Tissue Res.* 309, 73-88.

Hansen, K.H., Sakamoto, K., Obrietan, K., 2011. MicroRNAs: a potential interface between the circadian clock and human health. *Genome Med.* 3, 10.

Hanström, B., 1938. Zwei Probleme betreffs der hormonalen Localisation in Insektenkopf. *Kgl. Fysiogr. Sällsk. Lund. Förh.* 49, 1-17.

Hardin, P.E., 1994. Analysis of period mRNA cycling in *Drosophila* head and body tissues indicates that body oscillators behave differently from head oscillators. *Mol. Cell. Biol.* 14, 7211-7218.

Hardin, P.E., 2006. Essential and expendable features of the circadian timekeeping mechanism. *Curr. Opin. Neurobiol.* 16, 686-692.

Hardin, P.E., 2009. Molecular mechanisms of circadian timekeeping in *Drosophila*. *Sleep Biol. Rhythms* 7, 235-242.

Hardin, P.E., Hall, J.C., Rosbash, M., 1990. Feedback of the *Drosophila period* gene product on circadian cycling of its messenger RNA levels. *Nature* 343, 536-540.

Hardin, P.E., Siwicki, K.K., 1995. The multiple roles of *per* in the *Drosophila* circadian clock. *Sem. Neurosci.* 7, 15-25.

Harker, J.E., 1958. Diurnal rhythms in the animal kingdom. *Biol. Rev.* 33, 1-52.

Harmar, A.J., Marston, H.M., Shen, S., Spratt, C., West, K.M., Sheward, W.J., Morrison, C.F., Dorin, R.J., Piggins, H.D., Reubi, J.C., Kelly, J.S., Maywood, E.S., Hastings, M.H., 2002. The VPAC2 receptor is essential for circadian function in the mouse suprachiasmatic nuclei. *Cell* 109, 497-508.

Harmer, S.L., 2009. The circadian system of higher plants. *Ann. Rev. Plant Biol.* 60, 357-377.

Harrisingh, M.C., Wu, Y., Lanenicka, G.A., Nitabach, M.N., 2007. Intracellular Ca^{2+} regulates free-running circadian clock oscillation *in vivo*. *J. Neurosci.* 27, 12489-12499.

Hartenstein, V., 2006. The neuroendocrine system of invertebrates: a developmental and evolutionary perspective. *J. Endocrinol.* 190, 555-570.

Hastings, M., O'Neill, J.S., Maywood, E.S., 2007. Circadian clocks: regulators of endocrine and metabolic rhythms. *J. Endocrinol.* 195, 187-198.

Hastings, M.H., Maywood, E.S., O'Neill, J.S., 2008. Cellular circadian pacemaking and the role of cytosolic rhythms. *Curr. Biol.* 18, R805-R815.

Hattar, S., Liao, H.-W., Takao, M., Berson, D.M., Yau, K.-W., 2002. Melanopsin-containing retinal ganglion cells: architecture, projections, and intrinsic photosensitivity. *Science* 295, 1065-1070.

Haus, E., 2007. Chronobiology in the endocrine system. *Adv. Drug Deliver. Rev.* 59, 985-1014.

Haus, E.L., Smolensky, M.H., 2013. Shift work and cancer risk: Potential mechanistic roles of circadian disruption, light at night, and sleep deprivation. *Sleep Med. Rev.* 17, 273-284

Hayden, P., Lindberg, R.G., 1969. Circadian rhythm in mammalian body temperature entrained by cyclic pressure changes. *Science* 164, 1288-1289.

Hazlerigg, D.G., Wagner, G.C., 2006. Seasonal photoperiodism in vertebrates: from coincidence to amplitude. *Trends Endocrin. Met.* 17, 83-91.

He, P.-J., Hirata, M., Yamauchi, N., Hashimoto, S., Hattori, M.-a., 2007. Gonadotropic regulation of circadian clockwork in rat granulosa cells. *Mol. Cell. Biochem.* 302, 111-118.

Hege, D.M., Stanewsky, R., Hall, J.C., Giebultowicz, J.M., 1997. Rhythmic expression of PER-reporter in the Malpighian tubules of decapitated *Drosophila*: evidence for a brain-independent circadian clock. *J. Biol. Rhythms* 12, 300-308.

Heigl, S., Gwinner, E., 1994. Periodic melatonin in the drinking water synchronizes circadian rhythms in sparrows. *Naturwissenschaften* 81, 83-85.

Heigl, S., Gwinner, E., 1995. Synchronization of circadian rhythms of house sparrows by oral melatonin: effects of changing period. *J. Biol. Rhythms* 10, 225-233.

Helbling, P., Graf, R., 1998. Localization of the mosquito insulin receptor homologue (MIR) in reproducing yellow fever mosquitoes (*Aedes aegypti*). *J. Insect Physiol.* 44, 1127–1135.

Helfrich-Förster, C., 1995. The *period* clock gene is expressed in central nervous system neurons which also produce a neuropeptide that reveals the projections of circadian pacemaker cells within the brain of *Drosophila melanogaster*. *Proc. Natl. Acad. Sci. USA* 92, 612-616.

Helfrich-Förster, C., 2003. The neuroarchitecture of the circadian clock in the brain of *Drosophila melanogaster*. *Microsc. Res. Tech.* 62, 94-102.

Helfrich-Forster, C., 2004. The circadian clock in the brain: a structural and functional comparison between mammals and insects. *J. Comp. Physiol. A* 190, 601-613.

Helfrich-Forster, C., 2005. Organization of endogenous clocks in insects. *Biochem. Soc. Trans.* 33, 957-961.

Henrich, V.C., 2009. The ecdysteroid receptor. In: Gilbert, L.I. (Ed.), *Insect Development: Morphogenesis, Molting and Metamorphosis*, Elsevier, New York, pp. 261-304.

Hentze, J.L., Moeller, M.E., Jorgensen, A.F., Bengtsson, M.S., Bordoy, A.M., Warrens, J.T., Gilbert, L.I., Andersen, O., Rewitz, K.F., 2013. Accessory gland as a site for prothoracicotropic hormone controlled ecdysone synthesis in adult male insects. *PLoS ONE* 8, e55131.

Herman, J.P., Watson, S.J., Chao, H.M., Coirini, H., McEwen, B.S., 1993. Diurnal regulation of glucocorticoid receptor and mineralocorticoid receptor mRNAs in rat hippocampus. *Mol. Cell. Neurosci.* 4, 181-190.

Herzog, E.D., Takahashi, J.S., Block, G.D., 1998. *Clock* controls circadian period in isolated suprachiasmatic nucleus neurons. *Nat. Neurosci.* 1, 708-713.

Herzog, E.D., Aton, S.J., Numano, R., Sakaki, Y., Tei, H., 2004. Temporal precision in the mammalian circadian system: a reliable clock from less reliable neurons. *J. Biol. Rhythms* 19, 35-46.

Hill, H.D., 1757. *The Sleep of Plants*. (London: R. Baldwin).

Hoffmann, K.H., Weidner, K. Seidel, M., 1992. Sites of ecdysteroid biosynthesis in female adults of *Gryllus bimaculatus* (Ensifera, Gryllidae). J. Comp. Physiol. B. 162, 731-739.

Homberg, U., Würden, S., Dircksen, H., Rao, K.R., 1991. Comparative anatomy of pigment-dispersing hormone-immunoreactive neurons in the brain of orthopteroïd insects. Cell Tissue Res. 266, 343-357.

Homberg, U., Reischig, T., Stengl, M., 2003. Neural organization of the circadian system of the cockroach *Leucophaea maderae*. Chronobiol. Int. 20, 577-591.

Honma, K., Honma, S., 1988. A human phase response curve for bright light pulses. Jpn. J. Psychiatry Neurol. 42, 167-168.

Honma, K., Honma, S., Hiroshige, T., 1987. Activity rhythms in the circadian domain appear in suprachiasmatic nuclei lesioned rats given methamphetamine. Physiol Behav. 40, 767-774.

Honma, S., Shirakawa, T., Nakamura, W., Honma, K., 2000. Synaptic communication of cellular oscillations in the rat suprachiasmatic neurons. Neurosci. Lett. 294, 113-116.

Hua, Y.-J., Tanaka, Y., Nakamura, K., Sakakibara, M., Nagata S., Kataoka, H., 1999.

Identification of a prothoracicostatic peptide in the larval brain of the silkworm, *Bombyx mori*. J. Biol. Chem. 274, 31169-31173.

Huber, R., Hoppe, W., 1965. Die Kristall- und Molekülstrukturanalyse der

Insektenverpuppungshormons Ecdyson mit der automatisierten Falmolekülmethode.

Chem. Ber. 98, 2403-2424.

Huebner, E., Anderson, E., 1972a. A cytological study of the ovary of *Rhodnius prolixus*.

I. The ontogeny of the follicular epithelium. J. Morph. 136, 459-494.

Huebner, E., Anderson, E., 1972b. A cytological study of the ovary of *Rhodnius prolixus*,

II. Oocyte differentiation. J. Morph. 137, 385-416.

Hunt, T., Sassone-Corsi, P., 2007. Riding tandem: circadian clocks and the cell cycle.

Cell 129, 461-464.

Hunter-Ensor, M., Ousley, A., Sehgal, A., 1996. Regulation of the *Drosophila* protein

timeless suggests a mechanism for resetting the circadian clock by light. Cell 84, 677-

685.

Hurd, M.W., Debruyne, J., Straume, M., Cahill, G.M., 1998. Circadian rhythms of locomotor activity in zebrafish. *Physiol. Behav.* 65, 465-472.

Ichikawa, M., Ishizaki, H., 1963. Protein nature of the brain hormone in insects. *Nature* 198, 308-309.

Iliev, D., Voytsekh, O., Mittag, M., 2006. The circadian system of *Chlamydomonas reinhardtii*. *Biol. Rhythms Res.* 37, 323-333.

Ishida, A., Mutoh, T., Ueyama, T., Bando, H., Masubuchi, S., Nakahara, D., Tsujimoto, G., Okamura, H., 2005. Light activates the adrenal gland: timing of gene expression and glucocorticoid release. *Cell Metab.* 2, 297-307.

Ishizaki, H., Ichikawa, M., 1967. Purification of the brain hormone of the silkworm, *Bombyx mori*. *Biol. Bull.* 133, 355-368.

Ishizaki, H., Mizoguchi, A., Fujishita, M., Suzuki, A., Moryia, I., O'oka, H., Kataoka, H., Isogai, A., Nagasawa, H., Tamura, S., Suzuki, A., 1983. Species specificity of the insect prothoracicotropic hormone (PTTH): The presence of *Bombyx*- and *Samia*-specific PTTHs in the brain of *Bombyx mori*. *Devel. Growth Different.* 25, 593-600.

Ito, Y., Yasuda, A., Sonobe, H. 2008. Synthesis and phosphorylation of ecdysteroids during ovarian development in the silkworm, *Bombyx mori*. *Zool. Sci.* 25, 721-727.

Ivanchenko, M., Stanewsky, R., Giebultowicz, J.M., 2001. Circadian photoreception in *Drosophila*: Functions of cryptochrome in peripheral and central clocks. *J. Biol. Rhythm* 16, 205-215.

Jacklet, J.W., 1969. Circadian rhythm of optic nerve impulses recorded in darkness from isolated eye of *Aplysia*. *Science* 164, 562-563.

Jacklet, J.W., 1988. Circadian pacemaker neurons: membranes and molecules. *J. Physiol. (Paris)* 83, 164-171.

Jacklet, J.W., Geronimo, J., 1971. Circadian rhythm: population of interacting neurons. *Science* 174, 299-302.

Jacklet, J.W., Colquhoun, W., 1983. Ultrastructure of photoreceptors and circadian pacemaker neurons in the eye of a gastropod, *Bulla*. *J. Neurocytol.* 12, 673-696.

Jacklet, J., Barnes, S., Bulloch, A., Lukowiak, K., Syed, N., 1996. Rhythmic activities of isolated and clustered pacemaker neurons and photoreceptors of *Aplysia* retina in culture. *J. Neurobiol.* 31, 16-28.

Jacobson, L., 2005. Hypothalamic-pituitary-adrenocortical axis regulation. *Endocrinol. Metab. Clin. North Am.* 34, 271-92.

Jindra, M., Palli, S.R., Riddiford, L.M., 2013. The juvenile hormone signaling pathway in insect development. *Ann. Rev. Entomol.* 58, 181-204.

Johnson, C.H., 1999. 40 years of PRCs - What have we learned? *Chronobiol. Int.* 16, 711-743.

Johnson, C.H., Mori, T., Xu, Y., 2008. A cyanobacterial circadian clockwork. *Curr. Biol.* 18, R816-R825.

Kadener, S., Menet, J.S., Sugino, K., Horwich, M.D., Weissbein, U., Nawathean, P., Vagin, V.V., Zamore, P.D., Nelson, S.B., Rosbash, M., 2009. A role for microRNAs in the *Drosophila* circadian clock. *Genes Dev.* 23, 2179-2191.

Kaiser, T.S., Neumann, D., Heckel, D.G., 2011. Timing the tides: Genetic control of diurnal and lunar emergence times is correlated in the marine midge *Clunio marinus*. *BMC Genet.* 12, 49.

Kalsbeek, A., Fliers, E., 2013. Daily regulation of hormone profiles. *Handb. Exp. Pharmacol.* 217, 185-226.

Kalsbeek, A., Teclemariam-Mesbah, R., Pévet, P., 1993. Efferent projections of the suprachiasmatic nucleus in the golden hamster (*Mesocricetus auratus*). *J. Comp. Neurol.* 332, 293-314.

Kaneko, M., Hernandez-Borsetti, N., Cahill, G.M., 2006. Diversity of zebrafish peripheral oscillators revealed by luciferase reporting. *Proc. Natl. Acad. Sci. USA* 103, 14614-14619.

Karatsoreos, I.N., 2012. Effects of circadian disruption on mental and physical health. *Curr. Neurol. Neurosci. Rep.* 12, 218-225.

Karman, B.N., Tischkau, S.A., 2006. Circadian clock gene expression in the ovary: effects of luteinizing hormone. *Biol. Reprod.* 75, 624-632.

Kataoka, H., Nagasawa, H., Isogai, A., Ishizaki, H., Suzuki, A., 1991. Prothoracicotropic hormone of the silkworm, *Bombyx mori*: amino acid sequence and dimeric structure. *Agric. Biol. Chem.* 55, 73-86.

Kataoka, H., Nagasawa, H., Isogai, A., Tamura, S., Mizoguchi, A., 1987. Isolation and partial characterization of a prothoracicotropic hormone of the silkworm, *Bombyx mori*. *Agr. Biol. Chem. Tokyo* 51, 1067-1076.

Kennaway, D.J., Boden, M.J., Varcoe, T.J., 2012. Circadian rhythms and fertility. *Mol. Cell. Endocrinol.* 349, 56-61.

Khalsa, S.B.S., Jewett, M.E., Cajochen, C., Czeisler, C.A., 2003. A phase response curve to single bright light pulses in human subjects. *J. Physiol.* 549, 945-952.

Kiesel, A., 1894. Untersuchungen zur Physiologie des facettierten Auges. *Sitzungsber Akad. Wiss. Wien.* 103, 97-139.

King, D.P., Zhao, Y., Sangoram, A.M., Wislbacher, L.D., Tanaka, M., Antoch, M.P., Kornhauser, J.M., Lowrey, P.L., Turek, F.W., Takahashi, J.S., 1997. Positional Cloning of the Mouse Circadian *Clock* Gene. *Cell* 89, 641-653.

Kirimura, J., Saito, M., Kobayashi, M., 1962. Steroid hormone in an insect, *Bombyx mori*. *Nature* 195, 725-730.

Kitayama, Y., Nishiwaki, T., Terauchi, K., Kondo, T., 2008. Dual KaiC based oscillations constitute the circadian system of cyanobacteria. *Genes Dev.* 22, 1513-1521.

Klein, D.C., Moore, R.Y., 1979. Pineal N-acetyltransferase and hydroxy-indole-O methyltransferase: control by the retinohypothalamic tract and the suprachiasmatic nucleus. *Brain Res.* 174, 245-262.

Klein, D.C., Weller, J.L., 1970. Indole metabolism in the pineal gland: a circadian rhythm in N-acetyltransferase. *Science* 169, 1093-1095.

Knuttsen, S., 2003. Health disorders of shift workers. *Occup. Med. (Oxf.)* 53, 103-108.

Ko, C.H., Takashi, J.S., 2006. Molecular components of the mammalian circadian clock. *Hum. Mol. Genet.* 15, R271-R277.

Kobayashi, M., Kirimura, J., 1958. The brain hormone in the silkworm, *Bombyx mori* L. *Nature* 181, 117.

Kobayashi, M., Yamasaki, M., 1966. The proteinic brain hormone in an insect, *Bombyx mori* L. *Appl. Ent. Zool.* 1, 53-60.

Kojima, D., Fukuda, Y., 1999. Non-visual photoreception by a variety of vertebrate opsins. *Novartis Found. Symp.* 224, 265-279.

Kojima, S., Shingle, D.L., Green, C.B., 2011. Post-transcriptional control of circadian rhythms. *J. Cell Sci.* 124, 311-320.

Kondo, T., Mori, T., Lebedeva, N.V., Aoki, S., Ishiura, M., Golden, S.S., 1997. Circadian rhythms in rapidly dividing cyanobacteria. *Science* 275, 224-227.

Konopka, R., Benzer, S., 1971. Clock mutants of *Drosophila melanogaster*. *Proc. Natl Acad. Sci. USA* 68, 2112-2116.

Konopova, B., Jindra, M., 2007. Juvenile hormone resistance gene *Methoprene-tolerant* controls entry into metamorphosis in the beetle *Tribolium castaneum*. *Proc. Natl. Acad. Sci. USA* 104, 10488-10493.

Kopeč, S., 1917. Experiments on metamorphosis of insects. *Bull. Int. Acad. Cracovie B.*, 57-60.

Kopeč, S., 1922. Studies on the necessity of the brain for inception of insect metamorphosis. *Biol. Bull.* 42, 322-342.

Kotwica, J., Larson, M., Bebas, P., J.M. Giebultowicz, J.M., 2009. Developmental profiles of PERIOD and DOUBLETIME in *Drosophila melanogaster*. *J. Insect Physiol.* 55, 419-425.

Kriegsfeld, L.J., Silver, R., 2006. The regulation of neuroendocrine function: Timing is everything. *Hormones Behav.* 49, 557-574.

Krishnan, B., Dryer, S.E., Hardin, P.E., 1999. Circadian rhythms in olfactory responses of *Drosophila melanogaster*. *Nature* 400, 375-378.

Krishnan, B., Levine, J.D., Lynch, M.K., Dowse, H.B., Funes, P., Hall, J.C., Hardin, P.E., Dryer, S.E., 2001. A new role for cryptochrome in a *Drosophila* circadian oscillator. *Nature*. 411, 313-317.

Krupp, J.J., Kent, C., Billeter, J.-C., Azanchi, R., So, A.K.-C., Schonfeld, J.A., Smith, B.P., Lucas, C., Levine, J.D., 2008. Social experience modifies pheromone expression and mating behavior in male *Drosophila melanogaster*. *Curr. Biol.* 18, 1373-1383.

Kume, K., Zylka, M.J., Sriram, S., Shearman, L.P., Weaver, D.R., Jin, X., Maywood, E.S., Hastings, M.H., Reppert, S.M., 1999. mCRY1 and mCRY2 are essential components of the negative limb of the circadian clock feedback loop. *Cell* 98, 193-205.

Lafont, R., Dauphin-Vilemant, C., Warren, J. T., Rees, H., 2005. Ecdysteroid chemistry and biochemistry. In: Gilbert, L. I., Iatrou, K., Gill, S.G. (Eds.), *Comprehensive Molecular Insect Science*, vol. 3. Elsevier, Oxford, pp. 125-195.

Lagueux, M., Harry, P., Hoffman, J.A., 1981. Ecdysteroids are bound to vitellin in newly laid eggs of *Locusta*. *Mol. Cell. Endocrinol.* 24, 325-338.

Lagueux, M., Hetru, C., Goltzene, F., Kappler, C., Hoffman, J.A., 1979. Ecdysone titre and metabolism in relation to cuticulogenesis in embryos of *Locusta migratoria*. *J. Insect Physiol.* 25, 709-723.

Lakin-Thomas, P.L., 2006. Transcriptional feedback oscillators: maybe, maybe not. *J. Biol Rhythm* 21, 83-92.

Lea, A.O., 1972. Regulation of egg maturation in the mosquito by the neurosecretory system: the role of the corpus cardiacum. *Gen. Comp. Endocrinol.* 3 (Suppl), 602-608.

Leak, R.K., Card, J.P., Moore, R.Y., 1999. Suprachiasmatic pacemaker organization analyzed by viral transynaptic transport. *Brain Res.* 819, 23-32.

Li, S., Motavaze, K., Kafes, E., Suntharalingam, S., Lakin-Thomas, P., 2011. A new mutation affecting FRQ-less rhythms in the circadian system of *Neurospora crassa*. *PLoS Genet.* 7, e1002151.

Li, Y., Zhang, Z., Robinson, G.E., Palli, S.R., 2007. Identification and characterization of a juvenile hormone response element and its binding proteins. *J. Biol. Chem.* 282, 37605-37617.

Lin, H., Yin, C.-M., Stoffolano Jr., J.G., Garofolo, R.S., 2005. Immunological localization of mosquito ovary ecdysteroidogenic hormone I and fruit fly insulin receptor in adult *Phormia regina* (Diptera: Calliphoridae). *Ann. Entomol. Soc. Amer.* 98, 329-335.

Liu, A.C., Welsh, D.K., Ko, C.H., Tran, H.G., Zhang, E.E., Priest, A.A., Buhr, E.D., Singer, O., Meeker, K., Verma, I.M., Doyle, F.J., Takahashi, J.S., Kay, S.A. 2007. Intercellular coupling confers robustness against mutations in the SCN circadian clock network. *Cell* 130, 605-616.

Liu, C., Reppert, S.M., 2000. GABA synchronizes clock cells within the suprachiasmatic circadian clock. *Neuron* 25, 123-128.

Liu, X., Lorenz, L., Yu, Q., Hall, J.C., Rosbash, M., 1988. Spatial and temporal expression of the *period* gene in *Drosophila melanogaster*. *Genes Dev.* 2, 228-238.

Liu, C., Weaver, D.R., Strogatz, S.H., Reppert, S.M., 1997. Cellular construction of a circadian clock: period determination in the suprachiasmatic nuclei. *Cell* 91, 855-860.

Loeb, M.J., De Loof, A., Gelman, D.B., Hakim, R.S., Jaffe, H., Kochansky, J.P., Meola, S.M., Schoofs, L., Steel, C., Vafopoulou, X., Wagner, R.M., Woods, C.W., 2001. Testis ecdysiotropin, an insect gonadotropin that induces synthesis of ecdysteroids. *Arch. Insect Biochem. Physiol.* 47, 181-188.

Logan, R.W., Sarkar, D.K., 2012. Circadian nature of immune function. *Mol. Cell. Endocrinol.* 349, 82-90.

Loher, W., 1972. Circadian control of stridulation in the cricket *Teleogryllus commodus* Walker. *J. Comp. Physiol.* 79, 173-190.

Long, M.A., Jutras, M.J., Connors, B.W., Burwell, R.D., 2005. Electrical synapses coordinate activity in the suprachiasmatic nucleus. *Nat. Neurosci.* 8, 61-66.

Luborsky-Moore, J.L., Jacklet, J.W., 1977. Ultrastructure of the secondary cells in the *Aplysia* eye. *J. Ultrastruct. Res.* 60, 235-245.

Lupien, M., Marshall, S., Leser, W., Pollack, G.S., Honegger, H.W., 2003. Antibodies against the PER protein of *Drosophila* label neurons in the optic lobe, central brain, and thoracic ganglia of the crickets *Teleogryllus commodus* and *Teleogryllus oceanicus*. *Cell Tissue Res.* 312, 377-391.

Mabood, S.F., Newman, P.F., Nimmo, I.A., 1978. Circadian rhythms in the activity of acetylcholinesterase of human erythrocytes incubated *in vitro*. *Biochem. Soc. Trans.* 6, 305-308.

De Mairan, M., 1729. Observation botanique. *Hist. de l'Acad. Royal Sciences, Paris*, p 1.

Manjunatha, T., Dass, S.H., Sharma, V.K., 2008. Egg-laying rhythm in *Drosophila melanogaster*. *J. Genet.* 87, 495-504.

Manière, G., Rondot, I., Büllsbach, E.E., Gautron, F., Vanhems, E., Delbecque, J.P., 2004. Control of ovarian steroidogenesis by insulin-like peptides in the blowfly (*Phormia regina*). *J. Endocrinol.* 181, 147-156.

Manière, G., Vanhems, E., Rondot, I., Delbecque, J.-P., 2009. Control of ovarian steroidogenesis in insects: a locust neurohormone is active *in vitro* on blowfly ovaries. *Gen. Comp. Endocr.* 163, 292-297.

Marcheva, B., Ramsey, K.M., Buhr, E.D., Kobayashi, Y., Su, H., Ko, C.H., Ivanova, G., Omura, C., Mo, S., Vitaterna, M.H., Lopez, J.P., Philpson, L.H., Bradfield, C.A., Crosby, S.D., JeBailey, L., Wang, X., Takahashi, J.S., Bass, J., 2010. Disruption of the clock

components CLOCK and BMAL1 leads to hypoinsulinaemia and diabetes. *Nature* 466, 627-631.

Masri, S., Cervantes, M., Sassone-Corsi, P., 2013. The circadian clock and cell cycle: interconnected biological circuits. *Curr. Opin. Cell Biol.* 25, 730-734.

Masumura, M., Satake, S.I., Saegusa, H., Mizoguchi, A., 2000. Glucose stimulates the release of bombyxin, an insulin-related peptide of the silkworm *Bombyx mori*. *Gen. Comp. Endocrinol.* 118, 393–399.

Maywood, E.S., Reddy, A.B., Wong, G.K.Y., O'Neill, J.S., O'Brien, J.A., McMahon, D.G., Harmar, A.J., Okamura, H., Hastings, M.H., 2006. Synchronization and maintenance of timekeeping in suprachiasmatic circadian clock cells by neuropeptidergic signaling. *Curr. Biol.* 16, 599-605.

McBayer, Z., Ono, H., Shimell, M.J., Parvy, J.-P., Beckstead, R.B., Warren, J.T., Thummel, C.S., Dauphin-Villemant, C., Gilbert, L.I., O'Connor, M.B., 2007. Prothoracicotropic hormone regulates developmental timing and body size in *Drosophila*. *Dev. Cell.* 13, 857–871.

McClung, C.R., 2006. Plant circadian rhythms. *Plant Cell* 18, 792-803.

Mehra, A., Baker, C.L., Loros, J.J., Dunlap, J.C., 2009. Post-translational modifications in circadian rhythms. *Trends Biochem. Sci.* 34, 483-490.

Meijer, J.H., Michel, S., Vansteensel, M.J., 2007. Processing of daily and seasonal light information in the mammalian circadian clock. *Gen. Comp. Endocrinol.* 152, 159-164.

Meissner, R.-A., Kilman, V.L., Lin, J.-L., Allada, R., 2008. TIMELESS is an important mediator of CK2 effects on circadian clock function *in vivo*. *J. Neurosci.* 28, 9732-9740.

Menaker, M., Moreira, L.F., Tosini, G., 1997. Evolution of circadian organization in vertebrates. *Braz. J. Med. Biol. Res.* 30, 305-313.

Mendoza, J., 2006. Circadian clocks: setting time by food. *J. Neuroendocrinol.* 19, 127-137.

Mergenhagen, D., Schweiger, H.G., 1975a. Circadian rhythm of oxygen evolution in cell fragments of *Acetabularia mediterranea*. *Exp. Cell Res.* 92, 127-130.

Mergenhagen, D., Schweiger, H.G., 1975b. The effect of different inhibitors of transcription and translation on the expression and control of circadian rhythm in individual cells of *Acetabularia*. *Exp. Cell Res.* 94, 321-326.

Merlin, C., Lucas, P., Rochat, D., François, M.C., Maibèche-Coisne, Jacquin-Joly, E., 2007. An antennal circadian clock and circadian rhythms in peripheral pheromone reception in the moth *Spodoptera littoralis*. *J. Biol. Rhythms* 22, 502-514.

Merlin, C., Gegear, R.J., Reppert, S.M., 2009. Antennal circadian clocks coordinate sun compass orientation in migratory monarch butterflies. *Science* 325, 1700-1704.

Merrow, M.W., Garceau, N.Y., Dunlap, J.C., 1997. Dissection of a circadian oscillation into discrete domains. *Proc. Natl. Acad. Sci. USA* 94 3877-3882.

Meyer-Bernstein, E.L., Jetton, A.E., Matsumoto, S.I., Markuns, J.F., Lehman, M.N., Bittman, E.L., 1999. Effects of suprachiasmatic transplants on circadian rhythms of neuroendocrine function in golden hamsters. *Endocrinology* 140, 207-218.

Meyers, A.S., Schneiderman, H.A., Hanzmann, E., Ko, J., 1968. The two juvenile hormones from the cercropia silkworm. *Proc. Natl Acad. Sci. USA* 60, 853-860.

Michel, S., Geusz, M.E., Zaritsky, J.J., Block, G.D., 1993. Circadian rhythm in membrane conductance expressed in isolated neurons. *Science* 259, 239-241.

Michel, S., Schoch, K., Stevenson, P.A., 2000. Amine and amino acid transmitters in the eye of the mollusc *Bulla gouldiana*: an immunocytochemical study. *J. Comp. Neurol.* 425, 244-256.

Minh, N.L., Damiola, F., Tronche, F., Schutz, G., Schibler, U., 2001. Glucocorticoid hormones inhibit food-induced phase-shifting of peripheral circadian oscillators. *EMBO* 20, 7128-7136.

Mizoguchi, A., Ishizaki, H., 1982. Prothoracic glands of the saturniid moth *Samia cynthia ricini* possess a circadian clock controlling gut purge timing. *Proc. Natl. Acad. Sci. USA* 79, 2729-2730.

Mizoguchi, A., Oka, T., Kataoka, H., Nagasawa, H., Suzuki, A., Ishizaki, H., 1990, Immunohistochemical localization of prothoracicotropic hormone-producing cells in the brain of *Bombyx mori*. *Devel. Growth Different.* 52, 591-598.

Mohawk, J.A., Baer, M.L., Menaker, M., 2009. The methamphetamine-sensitive circadian oscillator does not employ canonical clock genes. *Proc. Natl. Acad. Sci. USA* 106, 3519-3124.

Moore, R. Y., Eichler, V.B., 1972. Loss of a circadian adrenal corticosterone rhythm following suprachiasmatic lesions in the rat. *Brain Res.* 42, 201-206.

Moore, R.Y., Klein, D.C., 1974. Visual pathways and the central neural control of a circadian rhythm in pineal serotonin N-acetyltransferase activity. *Brain Res.* 71, 17-33.

Moore-Ede, M., Sulzman, F.M., Fuller, C.A., 1982. The Clocks That Time Us: Physiology of the Circadian Timing System. Harvard University Press, Harvard, Mass., pp. 464.

Morgan, P.J., Barrett, P., Howell, H.E., Helliwell, R., 1994. Melatonin receptors: localization, molecular pharmacology and physiological significance. *Neurochem. Int.* 24, 101-146.

Morris, C.J., Aeschbach, D., Sheer, F.A.J.L., 2012. Circadian system, sleep and endocrinology. *Mol. Cell. Endocrinol.* 349, 91-104.

Murakami, M., Nakamura, H., Nishi, R., Marumoto, N., Nasu, T., 1993. Comparison of circadian oscillation of melatonin release in pineal cells of house sparrow, pigeon and Japanese quail, using cell perfusing systems. *Brain Res.* 651, 209-214.

Murphy, Z.C., Pezuk, P., Menaker, M., Sellix, M.T., 2013. Effects of ovarian hormones on internal circadian organization in rats. *Biol. Reprod.* 89, 1-9.

Myers, M.M., Yu, J., Sehgal, A., 2003. Circadian control of eclosion: interaction between a central and peripheral clock in *Drosophila melanogaster*. *Curr. Biol.* 13, 526-533.

Na, Y.-J., Sung, J.H., Lee, S.C., Lee, Y.-J., Choi, Y.J., Park, W.-Y., Shin, H.S., Kim, J.H., 2009 Comprehensive analysis of microRNA-mRNA co-expression in circadian rhythm. *Exp. Mol. Med.* 41, 638-647.

Nagasawa, H., Kataoka, H., Isogai, A., Tamura, S., Suzuki, Y., Ishizaki, H., Mizoguchi, A., Fujiwara, Y., Suzuki, A., 1984. Amino-terminal amino-acid sequence of the silkworm prothoracicotropic hormone: homology with insulin. *Science* 226, 1344–1345.

Nagoshi, E., Saini, C., Bauer, C., Laroche, T., Naef, F., Schibler, U., 2004. Circadian gene expression in individual fibroblasts: cell-autonomous and self-sustained oscillators pass time to daughter cells. *Cell* 119, 693-705.

Nakahara, Y., Matsumoto, H., Kanamori, Y., Kataoka, H., Mizoguchi, A., Kiuchi, M., Kamimura, M., 2006. Insulin signaling is involved in hematopoietic regulation in an insect hematopoietic organ. *J. Insect Physiol.* 52, 105-111.

Nakajima, M., Imai, K., Ito, H., Nishiwaki, T., Murayama, Y., Iwasaki, H., Oyama, T., Kondo, T., 2005. Reconstitution of circadian oscillation of cyanobacterial KaiC phosphorylation *in vitro*. *Science.* 308, 414-415.

Nakao, N., Yasuo, S., Nishimura, A., Yamamura, T., Watanabe, T., Anraku, T., Okano, T., Fukuda, Y., Sharp, P., Ebihara, S., Yoshimura, T., 2007. Circadian clock gene

regulation of steroidogenic acute regulatory protein gene expression in preovulatory ovarian follicles. *Endocrinology* 148, 3031-3038.

Nakashima, H., Onai, K., 1996. The circadian conidiation rhythm in *Neurospora crassa*. *Cell Devel. Biol.* 7, 765-774.

Nemoto, M., Hara, K., 2007. Ecdysone receptor expression in developing and adult mushroom bodies of the ant *Camponotus japonicus*. *Dev. Genes Evol.* 217, 619-627.

Nishiitsutsuji-Uwo, J., Pittendrigh, C., 1968. Central nervous system control of circadian rhythmicity in the cockroach. II: The optic lobes, locus of the driving oscillator. *Zeitschrift der vergleichenden Physiologie* 58, 14-46.

Nitabach, M.N., Holmes, T.C., Blau, J., 2005. Membranes, ions, and clocks: Testing the Njus-Sulzman-Hastings model of the circadian oscillator. *Methods Enzymol.* 393, 682-693.

Nitabach, M.N., Taghert, P.H., 2008. Organization of the *Drosophila* circadian control circuit. *Curr. Biol.* 18, R84-R93.

Njus, N., Sulzman, F.M, Hastings, J.W., 1974. Membrane model of the circadian clock. *Nature* 248, 116-120.

Noguti, T., Adachi-Yamada, T., Katagiri, T., Kawakami, A., Iwami, M., Ishibashi, J., Kataoka, H., Suzuki, A., Go, M., Ishizaki, H., 1995. Insect prothoracicotropic hormone: a new member of the vertebrate growth factor superfamily. *FEBS Lett.* 376, 251-266.

Norgren Jr., R.B., Silver, R., 1989. Retinohypothalamic projections and the suprachiasmatic nucleus in birds. *Brain Behav. Evol.* 34, 73-83.

O'Donnell, M.J., 1985. Calcium action potentials in the developing oocytes of an insect *Rhodnius prolixus*. *J. Exp. Biol.* 119, 287-300.

O'Donnell, A.J., Schneider, P., McWatters, H.G., Reece, S.E., 2011. Fitness costs of disrupting circadian rhythms in malaria parasite. *Proc. R. Soc. B* 278, 2429-2436.

O'Neill, J.S., Reddy, A.B., 2011. Circadian clocks in human red blood cells. *Nature* 469, 498-504.

O'Neill, J.S., Maywood, E.S., Chesham, J.E., Takahashi, J.S., Hastings, M.H., 2008. cAMP-dependent signaling as a core component of the mammalian circadian pacemaker. *Science* 320, 949-953.

O'Neill, J.S., van Oojen, G., Dixon, L.E., Troein, C., Corellou, F., Bouget, F.-Y., Reddy, A.B., Millar, A.J., 2011. Circadian rhythms persist without transcription in a eukaryote. *Nature* 469, 554-558.

Ono, H., Rewitz, K.F., Shinoda, T., Itoyama, K., Petryk, A., Rybczynski, R., Jarcho, M., Warren, J.T., Marqués, G., Shimell, M.J., Gilbert, L.I., O'Connor, M.B. 2006. *spook* and *spookier* code for stage-specific components of the ecdysone biosynthetic pathway in Diptera. *Dev. Biol.* 298, 555-570.

Oster, H., Damerow, S., Kiessling, S., Jakubcakova, V., Abraham, D., Tian, J., Hoffmann, M.W., Eichele, G., 2006. The circadian rhythm of glucocorticoids is regulated by a gating mechanism residing in the adrenal cortical clock. *Cell Metab.* 4, 163-173.

Ouyang, Y., Andersson, C.R., Kondo, T., Golden, S.S., Johnson, C.H., 1998. Resonating circadian clocks enhance fitness in cyanobacteria. *Proc. Natl. Acad. Sci. USA* 95, 8660-8664.

Page, T.L., 1982. Transplantation of the cockroach circadian pacemaker. *Science* 216, 73-75.

Page, T., 1985. Clocks and circadian rhythms. In: Kerkut, G.A., Gilbert, L.I. (Eds.), *Comprehensive Insect Physiology, Biochemistry, and Pharmacology*, vol. 6. Pergamon, Oxford, pp. 577-652.

Page, T.L., Caldarola, P.C., Pittendrigh, C.S., 1977. Mutual entrainment of bilaterally distributed circadian pacemakers. *Proc. Natl. Acad. Sci. USA.* 74, 1277-1281.

Page, T.L., Nalovic, K.G., 1992. Properties of mutual coupling between the two circadian pacemakers in the eyes of the mollusc *Bulla gouldiana*. *J. Biol. Rhythms* 7, 213-226.

Page, T.L., Koelling, E., 2003. Circadian rhythm in olfactory response in the antennae controlled by the optic lobe in the cockroach. *J. Insect Physiol.* 43, 697-707.

Pascual, N., Cerda, X., Benito, B., Tomas, J., Piulachs, M.D., Belles, X., 1992. Ovarian ecdysteroid levels and basal oocyte development during maturation in the cockroach *Blattella germanica* (L.). *J. Insect Physiol.* 38, 339-348.

Patchin, S., Davey, K.G., 1968. The histology of vitellogenesis in *Rhodnius prolixus*. *J. Insect Physiol.* 14, 1815-1820.

Pavelka, J., Shimada, K., Kostal, V., 2003. TIMELESS: A link between fly's circadian and photoperiodic clocks? *Eur. J. Entomol.* 100, 255-265.

Pelc, D., Steel, C.G.H., 1997. Rhythmic steroidogenesis by the prothoracic glands of the insect *Rhodnius prolixus* in the absence of rhythmic neuropeptide input: Implications for the Role of prothoracicotropic hormone. *Gen. Comp. Endocrinol.* 108, 358-365.

Perreau-Lenz, S., Pévet, P., Buijs, R.M., Kalsbeek, A., 2004. The biological clock: a bodyguard of temporal homeostasis. *Chronobiology Int.* 21, 143-151.

Pévet, P., Agez, L., Bothorel, B., Saboureau, M., Gauer, F., Laurent, V., Masson- Pévet, M., 2006. Melatonin and the multi-oscillatory mammalian circadian world. *Chronobiology. Int.* 23, 39-51.

Pfeiffer, I.W., 1945. The influence of the corpora allata over the development of nymphal characters in the grasshopper *Melanoplus differentialis*. *Trans. Conn. Acad. Arts. Sci.* 36, 489-515.

Pflugfelder, O., 1937. Bau, Entwicklung und Funktion der Corpora allata und cardiaca von *Dixippus morosus* Br. *Z. Wiss. Zool.* 149, 477-512.

Piepho, H., 1942. Untersuchungen zur Entwicklungsphysiologie der Insekten. *Zool. Anz.* 14 suppl., 169-173.

Pittendrigh, C.S., 1958. Perspectives in the study of biological clocks. In: Buzzati-Traverso, A.A. (ed.) Perspectives in marine biology. University of California Press, Berkeley, pp. 239-268.

Pittendrigh, C.S., 1960. Circadian rhythms and the circadian organization of living systems. Cold Spring Harb. Symp. Quant. Biol. 25, 159-181.

Pittendrigh, C.S., 1993. Temporal organization: reflections of a Darwinian clock watcher. Ann. Rev. Physiol. 55, 17-54.

Pittendrigh, C.S., Minis, D.H., 1972. Circadian systems: longevity as a function of circadian resonance in *Drosophila melanogaster*. Proc. Natl. Acad. Sci. USA. 69, 1537-1539.

Pittendrigh, C.S., Bruce, V.G., Rosenweig, N.S. Rubin, M.L., 1959. Growth patterns in *Neurospora*: A biological clock in *Neurospora*. Nature 184, 169-170.

Pitts, S., Perone, E., Silver, R., 2003. Food-entrained circadian rhythms are sustained in arrhythmic Clk/Clk mutant mice. Am. J. Physiol. Regul. Integr. Comp. Physiol. 285, R57-R67.

- Plagge, E., 1938. Weitere Untersuchungen über das Verpuppungshormon bei Schmetterlingen. Biol. Zbl. 58, 1-12.
- Plautz, J.D., Kaneko, M., Hall, J.C., Kay, S.A., 1997. Independent photoreceptive circadian clocks throughout *Drosophila*. Nature 278, 1632-1635.
- Polanska, M.A., Maksimiuk-Ramirez, E., Ciuk, M.A., Kotwica, J., Bebas, P., 2009. Clock-controlled rhythm of ecdysteroid levels in the haemolymph and testes, and its relation to sperm release in the Egyptian cotton leafworm, *Spodoptera littoralis*. J. Insect Physiol. 55, 426-434.
- Possompès, B., 1953. Recherches expérimentales sur le déterminisme de la métamorphose de *Calliphora erythrocephala* Meig. Archiv. Zool. Exp. Gen. 89, 203-364.
- Pratt, G.E., Davey, K.G., 1972. The corpus allatum and oogenesis in *Rhodnius prolixus* (Stal.) I. The effects of allatectomy. J. Exp. Biol. 56, 201-214.
- Radtke, A., 1942. Hemmung der Verpuppung beim Mehlkäfer *Tenebrio molitor* L. Naturwissenschaften 30, 451-452.

Raihkel, A.S., Brown, M.R., Belles, X., 2005. Hormonal control of reproductive processes. In: Gilbert, L. I., Iatrou, K., Gill, S.G. (Eds.), *Comprehensive Molecular Insect Science*, vol. 3. Elsevier, Oxford, pp. 433-491.

Ralph, M. R., Menaker, M., 1988. A mutation of the circadian system in golden hamster. *Science* 241, 1225-1227.

Ralph, M.R., Foster, R.G., Davis, F.C., Menaker, M., 1990. Transplanted suprachiasmatic nucleus determines circadian Period. *Science* 247, 975-978.

Reddy, P., Zehring, W.A., Wheeler, D.A., Pirrotta, V., Hedfield, C., Hall, J.C., Rosbash, M., 1984. Molecular analysis of the *period* locus in *Drosophila melanogaster* and identification of a transcript involved in biological rhythms. *Cell* 38, 701-710.

Reick, M., Garcia, J.A., Dudley, C., McKnight, S.L., 2001. NPAS2: An analog of clock operative in the mammalian forebrain. *Science* 293, 506-509.

Reischig, T, Stengl, M., 2002. Optic lobe commissures in a three-dimensional brain model of the cockroach *Leucophaea maderae*: a search for the circadian coupling pathways. *J. Comp. Neurol.* 443, 388-400.

Reischig, T., Stengl, M., 2003. Ectopic transplantation of the accessory medulla restores circadian locomotor rhythms in arrhythmic cockroaches (*Leucophaea maderae*). J. Exp. Biol. 206, 1877-1886.

Reischig, T., Petri, B., Stengl, M., 2004. Pigment-dispersing hormone (PDH)-immunoreactive neurons form a direct coupling pathway between the bilaterally symmetric circadian pacemakers of the cockroach *Leucophaea maderae*. Cell Tissue Res. 318, 553-564.

Rence, B., Loher, W., 1975. Arrhythmically singing crickets: thermoperiodic reentrainment after bilobectomy. Science, 190, 385-387.

Reuss, S., 1996. Components and connections of the circadian timing system in mammals. Cell Tissue Res. 285, 353-378.

Rewitz, K.F., Yamanaka, N., Gilbert, L.I., O'Connor, M.B., 2009. The insect neuropeptide PTTH activates receptor tyrosine kinase Torso to initiate metamorphosis. Science 236, 1403-1405.

Richard, D.S., Rybczynski, R., Wilson, T.G., Wang, Y., Wayne, M.L., Zhou, Y., Partridge, L., Harshman, L.G., 2005. Insulin signaling is necessary for vitellogenesis in *Drosophila melanogaster* independent of the roles of juvenile hormone and ecdysteroids:

female sterility of the chico1 insulin signaling mutation is autonomous to the ovary. *J. Insect. Physiol.* 51, 455-464.

Riddiford, L.M., 1978. Ecdysone-induced change in cellular commitment of the epidermis of the tobacco hornworm, *Manduca sexta*, at the initiation of metamorphosis. *Gen. Comp. Endocr.* 34, 438-446.

Riddiford, L.M., 1985. Hormone action at the cellular level. In: Kerkut, G.A., Gilbert, L.I. (Eds.), *Comprehensive Insect Physiology, Biochemistry and Pharmacology*, vol. 7. Pergamon, Oxford, pp. 37-84.

Riddiford, L.M., 1994. Cellular and molecular actions of juvenile hormone. I. General considerations and premetamorphic actions. *Adv. Insect Physiol.* 24, 213-274.

Riddiford, L.M., 2012. How does juvenile hormone control insect metamorphosis and reproduction? *Gen. Comp. Endocrinol.* 179, 477-484.

Riehle, M.A., Brown, M.R., 1999. Insulin stimulates ecdysteroid production through a conserved signaling cascade in the mosquito *Aedes aegypti*. *Insect Biochem. Mol. Biol.* 29, 855-860.

Riehle, M.A., Brown, M.R., 2002. Insulin receptor expression during development and a reproductive cycle in the ovary of the mosquito *Aedes aegypti*. *Cell Tissue Res.* 308, 409–420.

Roberts, M.H., Block, G.D., 1983. Mutual coupling between the ocular circadian pacemakers of *Bulla gouldiana*. *Science* 221, 87-89.

Roberts, M.H., Block, G.D., 1985. Analysis of mutual circadian pacemaker coupling between the two eyes of *Bulla*. *J. Biol. Rhythms* 1, 55-75.

Robertson, L.M., Takahashi, J.S., 1988. Circadian clock in cell culture. I. Oscillation of melatonin release from dissociated chick pineal cells in flow-through microcarrier culture. *J. Neurosci.* 8, 12-21.

Roenneberg, T., 1996. The complex circadian system of *Gonyaulax polyedra*. *Physiologia Plantarum* 96, 733-737.

Roenneberg, T., Mellow, M., 1999. Circadian clocks - from genes to complex behaviour. *Reprod. Nutr. Dev.* 39, 277-294.

Roenneberg, T., Mellow, M., 2001. Circadian systems: different levels of complexity. *Philos. Trans. R. Soc. Lond. B. Biol. Sci.* 356, 1687-1696.

Roenneberg, T., Merrow, M., 2005. Circadian clocks – the fall and rise of physiology. *Nature Rev. Mol. Cell Biol.* 6, 965-971.

Roenneberg, T., Morse, D., 1993. Two circadian oscillators in one cell. *Nature* 362, 362-364.

Röller, H., Bjerke, J.S., 1965. Purification and isolation of juvenile hormone and its action in lepidopteran larvae. *Life Sci.* 4, 1617-1624.

Röller, H., Dahm, K.H., 1968. The chemistry and biology of juvenile hormone. *Recent Prog. Horm. Res.* 24, 651-680.

Rosbash, M., 2009. The implications of multiple circadian clock origins. *PLoS Biol.* 7, e1000062.

Roth, G.E., Gierl, M.S., Volborn, L., Meise, M., Lintermann, R., Korge, G., 2004. The *Drosophila* gene *Start1*: A putative cholesterol transporter and key regulator of ecdysteroid synthesis. *Proc. Natl. Acad. Sci. USA* 101, 1601-1606.

Ruan, G.-X., Zhang, D.-Q., Zhou, T., Yamazaki, S., McMahon, D.G., 2006. Circadian organization of the mammalian retina. *Proc. Natl Acad Sci. USA* 103, 9703-9708.

Ruan, G.-X., Allen, G.C., Yamazaki, S., McMahon, D.G., 2008. An autonomous circadian clock in the inner mouse retina regulated by dopamine. *PLOS Biol.* 6, 2248-2265.

Rubenstein, E.C., Kelly, T.J., Schwartz, M.B., Woods, C.W., 1982. In vitro synthesis and secretion of ecdysteroids by *Drosophila melanogaster* ovaries. *J. Exp. Zool.* 223, 305-308.

Rubin, E.B., Shemesh, Y., Cohen, M., Elgavish, S., Robertson, H., Bloch, G., 2006. Molecular and phylogenetic analyses reveal mammalian-like clockwork in the honey bee (*Apis mellifera*) and shed new light on the molecular evolution of the circadian clock. *Genome Res.* 16, 1352-1365.

Rudiger, H.N., 2004. Health problems due to night shift work and jet lag. *Internist* 45, 1021-1025.

Ruegg, R.P., Kriger, F.L., Davey, K.G., Steel, C.G.H., 1981. Ovarian ecdysone elicits release of a myotropic ovulation hormone in *Rhodnius* (Insecta: Hemiptera). *Int. J. Invertebr. Reprod.* 3, 357-361.

Rybczynski, R., 2009. Prothoracicotropic hormone. In: Gilbert, L.I. (Ed.), *Insect Development: Morphogenesis, Molting and Metamorphosis*, Elsevier, New York, pp 197-260.

Rymer, J., Bauernfeind, A.L., Brown, S., Page, T.L., 2007. Circadian rhythms in the mating behavior of the cockroach, *Leucophaea maderae*. *J. Biol. Rhythms* 22, 43-57.

Sadacca, L.A., Lamia, K.A., deLemos, A.S., Blum, B., Weitz, C.J., 2011. An intrinsic circadian clock of the pancreas is required for normal insulin release and glucose homeostasis in mice. *Diabetologia* 54, 120-124.

Saez, L., Young, M.W., 1988. *In Situ* localization of the per clock protein during development of *Drosophila melanogaster*. *Mol. Cell. Biol.* 8, 5378-5385.

Sahar, S., Sassone-Corsi, P., 2012. Regulation of metabolism: the circadian clock dictates the time. *Trends Endocrinol. Met.* 23, 1-8.

Sakai, T., Ishida, N., 2001. Circadian rhythms of female mating activity governed by clock genes in *Drosophila*. *Proc. Natl. Acad. Sci. U.S.A.* 98, 9221-9225.

Sall, C., Tsoupas, G., Kappler, C., Lagueux, M., Zachary, D., Luu, B., Hoffmann, J.A., 1983. Fate of maternal conjugated ecdysteroids during embryonic development in *Locusta migratoria*. *J. Insect Physiol.* 29, 491-507.

Satake, S.I., Masumura, M., Ishizaki, H., Nagata, K., Kataoka, H., Suzuki, A., Mizoguchi, A., 1997. Bombyxin, an insulin-related peptide of insects, reduces the major storage carbohydrates in the silkworm *Bombyx mori*. *Comp. Biochem. Physiol. B* 349–357.

Sauman, I., Reppert, S.M., 1996. Molecular characterization of prothoracicotropic hormone (PTTH) from the giant silkworm *Antheraea pernyi*: developmental appearance of PTTH-expressing cells and relationship to circadian clock cells in central brain. *Devel. Biol.* 178, 418-429.

Saunders, D.S., 1997. Insect circadian rhythms and photoperiodism. *Invertebr. Neurosci.* 3, 155-164.

Saunders, D.S., 2005. Erwin Bünning and Tony Lees, two giants of chronobiology, and the problem of time measurement in insect photoperiodism. *J. Insect Physiol.* 51, 599-608.

Saunders, D.S., 2009. Circadian rhythms and the evolution of photoperiodic timing in insects. *Physiol. Entomol.* 34, 301-308.

Scharrer, B., 1987. Insects as models in neuroendocrine research. *Ann. Rev. Entomol.* 32, 1-16.

Scharrer, B., Scharrer, E., 1944. Neurosecretion, IV. A comparison between the intercerebralis-cardiacum-allatum system of the insects and the hypothalamo-hypophyseal system of the vertebrates. *Biol. Bull.* 87, 242-251.

Schibler, I., Sassone-Corsi, P., 2002. A web of circadian pacemakers. *Cell* 111, 919-922.

Schlattner, U., Vafopoulou, X., Steel, C.G.H., Hormann, R.E., Lezzi, M., 2006. Non-genomic ecdysone effects and the invertebrate nuclear steroid hormone receptor EcR – new role for an ‘old’ receptor? *Mol. Cell. Endocr.* 247, 64-72.

Schmialek, P., 1961. Die Identifizierung zweier im Tenebrio und in Hefe vorkommender Substanzen mit Juvenilhormonwirkung. *Z. Naturf.* 16b, 461-464.

Schmutz, I., Albrecht, U., Ripperger, J.A., 2012. The role of clock genes and rhythmicity in the liver. *Mol. Cell. Endocrinol.* 349, 38-44.

Schoofs, L., Clynen, E., Cerstiaens, A., Baggerman, G., Wei, Z., Vercammen, T., Nachman, R., De Loof, A., Tanaka, S., 2001. Newly discovered functions for some myotropic neuropeptides in locusts. *Peptides* 22, 219-227.

Schukel, J., Siwicki, K.K., Stengl, M., 2007. Putative circadian pacemaker cells in the antenna of the hawkmoth *Manduca sexta*. *Cell Tissue Res.* 230, 271-278.

Schulze, T., Prager, K., Dathe, H., Kelm, J., Kiebling, Mittag, M., 2010. How the green alga *Chlamydomonas reinhardtii* keeps time. *Protoplasma* 244, 3-14.

Schwedes, C., Tulsiani, S., Carney, G.E., 2011. Ecdysone receptor expression and activity in adult *Drosophila melanogaster*. *J. Insect Physiol.* 57, 899-907.

Sedlak, B.J., 1985. Structure of endocrine glands. In: Kerkut, G. A., Gilbert, L. I. (Eds.), *Comprehensive Insect Physiology, Biochemistry, and Pharmacology*, v. 7. Pergamon, Oxford, England, pp. 25-60.

Sehgal, A., Price, J.L., Man, B., Young, M.W., 1994. Loss of circadian behavioral rhythms and per RNA oscillations in the *Drosophila* mutant timeless. *Science* 263, 1603-1606.

Sehnal, F., Svacha, P., Zrzavy, J., 1996. Evolution of insect metamorphosis. In: Gilbert, L.I., Tata, J.R., Atkinson, B.G., (eds.) *Metamorphosis: Postembryonic Reprogramming of Gene Expression in Amphibian and Insect Cells*, Academic Press, San Diego, CA, pp.3-58.

Sellix, M.T., Menaker, M., 2010. Circadian clocks in the ovary. *Trends Endocrinol. Metab.* 28, 628-636.

Shearman, L.P., Zylka, M.J., Weaver, D.R., Kolalowski Jr., L.F., Reppert, S.M., 1997. Two period homologs: circadian expression and photic regulation in the suprachiasmatic nuclei. *Neuron* 19, 1261-1269.

Shende, V.R., Goldrick, M.M., Ramani, S., Earnest, D.J., 2011. Expression and rhythmic modulation of circulating microRNAs targeting the clock gene *Bmal1* in mice. *PLoS One* 6, e22586.

Sheng, Z., Xu, J., Bai, H., Zhu, F., Palli, S.R., 2011. Juvenile hormone regulates vitellogenin gene expression through insulin-like peptide signaling pathway in the red flour beetle, *Tribolium castaneum*. *J. Biol. Chem.* 286, 41924-41936.

Shi, M., Zheng, X., 2013. Interactions between the circadian clock and metabolism: there are good times and bad times. *Acta Biochim. Biophys. Sin.* 45, 61-69.

Shiga, S., Numata, H., 2009. Roles of PER immunoreactive neurons in circadian rhythms and photoperiodism in the blow fly, *Protophormia terraenovae*. *J. Exp. Biol.* 212, 867-877.

Shimizu T., Cox K., Karten, H.J., Britto, L.R.G., 1994. Cholera toxin mapping of retinal projections in pigeons (*Columba livia*), with emphasis on retinohypothalamic connections. *Vis. Neurosci.* 11, 441-446.

Shimizu, T., Hirai, Y., Murayama, C., Miyamoto, C., Miyazaki, H., Miyazaki, K., 2011. Circadian Clock genes *Per2* and *clock* regulate steroid production, cell proliferation, and luteinizing hormone receptor transcription in ovarian granulosa cells. *Biochem. Biophys. Res. Comm.* 412, 132-135.

Sieglauff, D.H., Duncan, K.A., Brown, M.R., 2005. Expression of genes encoding proteins involved in ecdysteroidogenesis in the female mosquito, *Aedes aegypti*. *Insect Biochem. Mol. Biol.* 35, 471-490.

Simpson, S., Galbraith, J.J., 1905. An investigation into the diurnal variation of the body temperature of nocturnal and other birds and a few mammals. *J. Physiol.* 33, 225-238.

Siré, C., Moreno, A.B., Garcia-Chapa, M., Lopez-Moya, J.J., San Segundo, B., 2009. Diurnal oscillation in the accumulation of Arabidopsis microRNAs, miR167, miR168, miR171 and miR398. *FEBS Lett.* 583, 1039-1044.

Sláma, K., 1980. Homeostatic function of ecdysteroids in ecdysis and oviposition. *Acta Entomol. Bohemosl.* 73, 65-75.

Smith, W.A., Gilbert, L.I., Bollenbacher, W.E., 1984. The role of cyclic AMP interactions in the Regulation of ecdysone synthesis. *Mol. Cell. Endocrinol.* 37, 285-294.

Smith, W.A., Gilbert, L.I., Bollenbacher, W.E., 1985. Calcium-cyclic AMP interactions in prothoracicotropic hormone stimulation of ecdysone synthesis. *Mol. Cell. Endocrinol.* 39, 71-78.

Smith, W.A., Combest, W.L., Gilbert, L.I., 1986. Involvement of cyclic AMP-dependent protein kinase in prothoracicotropic hormone-stimulated ecdysone synthesis. *Mol. Cell. Endocrinol.* 47, 25-33.

Smith, A.F., Schal, C., 1991. Circadian calling behavior of the adult female brown-banded cockroach, *Supella longipalpa* (F.) (Dictyoptera: Blattellidae). *J. Insect Behav.* 4, 1-14.

Sokolove, P.G., 1975. Localization of the cockroach optic lobe circadian pacemaker with microlesions. *Brain Res.* 87, 13-21.

Sokolove, P.G., Loher, W., 1975. Rôle of eyes, optic lobes, and pars intercerebralis in locomotory and stridulatory circadian rhythms of *Teleogryllus commodus*. *J. Insect Physiol.* 21, 785-799.

Somers, D.E., 1999. The physiology and molecular bases of the plant circadian clock. *Plant Physiol.* 121, 9-19.

Son, G.H., Chung, S., Choe, H.K., Kim, H.-D., Baik, S.-M., Lee, H., Lee, H.-W., Choi, S., Sun, W., Kim, H., Cho, S., Lee, K.H., Kim, K., 2008. Adrenal peripheral clock controls the autonomous circadian rhythm of glucocorticoid by causing rhythmic steroid production. *Proc. Natl. Acad. Sci. USA* 105, 20970–20975.

Sonobe, H., Yamada, R., 2004. Ecdysteroids during early embryonic development in silkworm *Bombyx mori*: metabolism and functions. *Zool. Sci.* 21, 503-516.

Spindler, K.-D., Hönl, C., Tremmel, Ch., Braun, S., Ruff, H., Spindler-Barth, M., 2009. Ecdysteroid hormone action. *Cell Mol. Life Sci.* 66, 3837-3850.

Stanewsky, R., Kaneko, M., Emery, P., Beretta, B., Wager-Smith, K., Kay, S.A., Rosbash, M., Hall, J.C., 1998. The cryb mutation identifies cryptochrome as a circadian photoreceptor in *Drosophila*. *Cell* 95, 681-692.

Stankov, B., Cozzi, B., Lucini, V., Capsoni, S., Fautek., J., Fumagalli, P., Fraschini, F., 1991. Localization and characterization of melatonin binding sites in the rabbit (*Oryctolagus cuniculus*) by autoradiography and *in vitro* ligand-receptor binding. *Neurosci.* 133, 68-72.

Stay, B., Ostedgaard, L.S., Tobe, S.S., Strambi, A., Spaziani, A., 1984. Ovarian and haemolymph titres of ecdysteroid during the gonadotrophic cycle in *Diploptera punctata*. *J. Insect Physiol.* 30, 643-651.

Steel, C.G.H., Bollenbacher, W.E., Smith, S.L., Gilbert, L.I., 1982. Haemolymph ecdysteroid titres during larval-adult development in *Rhodnius prolixus*: correlations with moulting hormone action and brain neurosecretory cell activity. *J. Insect Physiol.* 28, 519-525.

Steel, C.G.H., Vafopoulou, X., 1989. Ecdysteroid titer profile during growth and development of arthropods. In: Koolman, J. (Ed.) *Ecdysone: from Chemistry to Mode of Action*, Georg Thieme Verlag, Stuttgart, pp. 221-231.

Steel, C.G.H., Vafopoulou, X., 2006. Circadian orchestration of developmental hormones in the insect, *Rhodnius prolixus*. *Comp. Biochem. Physiol. A* 144, 351-364.

Stengl, M., Homberg, U., 1994. Pigment-dispersing hormone-immunoreactive neurons in the cockroach *Leucophaea maderae* share properties with circadian pacemaker neurons. *J. Comp. Physiol.* 175, 203-213.

Stephan, F.K., 2002. The "other" circadian system: food as a Zeitgeber. *J. Biol. Rhythms* 17, 284-292.

Stephan, F. K., Zucker, I., 1972. Circadian rhythms in drinking behavior and locomotor activity of rats are eliminated by hypothalamic lesions. *Proc. Natl. Acad. Sci. USA* 69, 1583-1586.

Stocco, D., 2001. StAR protein and the regulation of steroid hormone biosynthesis. *Ann. Rev. Physiol.* 63, 193-213.

Stokkan, K.-A., Yamazaki, S., Tei, H., Sakaki, Y., Menaker, M., 2001. Entrainment of the circadian clock in the liver by feeding. *Science* 291, 490-493.

Szafarczyk, A., Ixart, G., Malaval, F., Nouguiet-Soule, J., Assenmacher, I., 1979. Effects of lesions of the suprachiasmatic nuclei and of p-chlorophenylalanine on the circadian

rhythms of adrenocorticotrophic hormone and corticosterone in the plasma, and on locomotor activity of rats. *J. Endocrinol.* 83, 1-16.

Swain, R.A., Nolan, J.V., Klieve, A.V., 1995. Natural variability and diurnal fluctuations within the bacteriophage population of the rumen. *Appl. Environ. Microbiol.* 62, 994-997.

Swevers, L., Iatrou, K. 2009. Ecdysteroids and Ecdysteroid Signaling Pathways During Insect Oogenesis. In: Smagghe, G. (Ed.), *Ecdysone: Structures and Functions*, Springer, New York, NY, pp. 127-163.

Takahashi, J.S., Menaker, M., 1979. Brain mechanisms in avian circadian systems. In: Suda, M., Hayaishi, O., Hachiro, N. (Eds.) *Biological Rhythms and their Central Mechanism*, Elsevier, Amsterdam, pp. 95-109.

Takahashi, J.S., Menaker, M., 1982. Role of the suprachiasmatic nuclei in the circadian system of the house sparrow (*Passer domesticus*). *J. Neurosci.* 2, 815-828.

Takahashi, J.S., Hamm, H., Menaker, M., 1980. Circadian rhythms of melatonin release from individual superfused chicken pineal glands *in vitro*. *Proc. Natl. Acad. Sci. USA* 77, 2319-2322.

Taniguchi, M., Murakami, N., Nakamura, H., Nasu, T, Shinohara, S., Etoh, T., 1993.

Melatonin release from pineal cells of diurnal and nocturnal birds. *Brain Res.* 620, 297-300.

Tanoue, S., Krishnan, P., Krishnan, B., Bryer, S.E., Hardin, P.E., 2004. Circadian clocks in antennal neurons are necessary and sufficient for olfaction rhythms in *Drosophila*.

Curr. Biol. 14, 638-649.

Tauber, E., Kyriacou, B.P., 2001. Insect photoperiodism and circadian clocks: models and mechanisms. *J. Biol. Rhythms* 16, 381-390.

Tawfik, A.I., Vedrová, A., Sehnal, F., 1999. Ecdysteroids during ovarian development and embryogenesis in solitary and gregarious *Schistocerca gregaria*. *Arch. Insect*

Biochem. Physiol. 41, 134-143.

Terry, K.L., Steel, C.G.H., 2001. Neuropeptides and steroid hormone rhythms are regulated by distinct cellular oscillators during the development of the insect *Rhodnius prolixus*. In: Goos, H.J.Th., Rastogi, R.K., Vaudry, H., Pierantoni, R. (Eds.), *Perspective in Comparative Endocrinology: Unity and Diversity*. Monduzzi Editore, Bologna, pp.

309-314.

Tessmar-Raible, K., Raible, F., Arboleda, E., 2011. Another place, another timer: Marine species and the rhythms of life. *Bioessays* 33, 165-172.

Tischkau, S.A., Howell, R.E., Hickock, J.R., Krager, S.L., Bahr, J.M., 2011. The luteinizing hormone surge regulates circadian clock gene expression in the chicken ovary. *Chronobiol. Int.* 28, 10–20.

Toh, K.L., Jones, C.R., He, Y., Eide, E.J., Hinz, W.A., Virshup, D.M., Ptacek, L.J., Fu, Y.H., 2001. An hPer2 phosphorylation site mutation in familial advanced sleep phase syndrome. *Science* 291, 1040-1043.

Tomioka, K., 1985. Residual circadian rhythmicity after bilateral lamina–medulla removal or optic stalk transection in the cricket, *Gryllus bimaculatus*. *J. Insect Physiol.*, 31: 653-657.

Tomioka, K., 1993. Analysis of coupling between optic lobe circadian pacemakers in the cricket *Gryllus bimaculatus*. *J. Comp. Physiol.* 172, 401-408.

Tomioka, K., Chiba, Y., 1984. Effects of nymphal stage optic nerve severance or optic lobe removal on the circadian locomotor rhythm of the cricket, *Gryllus bimaculatus*. *Zoolog. Sci.* 1, 375-382.

Tomioka, K., Yamada, K., Yokoyama, S., Chiba, Y., 1991. Mutual interactions between optic lobe circadian pacemakers in the cricket *Gryllus bimaculatus*. *J. Comp. Physiol.* 169, 291-298.

Tomioka, K., Uryu, O., Kamae, Y., Umezaki, Y., Yoshii, T., 2012. Peripheral circadian rhythms and their regulatory mechanism in insects and some other arthropods: a review. *J. Comp. Physiol. B* 182, 729-740.

Tonsfeldt, K.J., Chappell, P.E., 2012. Clocks on top: The role of the circadian clock in the hypothalamic and pituitary regulation of endocrine physiology. *Cell Mol. Endocrinol.* 349, 3-12.

Tosini, G., Fukuhara, C., 2002. The mammalian retina as a clock. *Cell Tissue Res.* 309, 119-126.

Tosini, G., Pozdeyev, N., Sakamoto, K., Iuvone, P.M., 2008. The circadian clock system in the mammalian retina. *BioEssays* 30, 624-633.

Truman, J.W., 2005. Hormonal control of insect ecdysis: endocrine cascades for coordinating behavior with physiology. *Vitam. Horm.* 73, 1-30.

Ueda, H. R., Chen, W., Adachi, A., Wakamatsu, H., Hayashi, S., Takasugi, T., Nagano, M., Nakahama, K., Sugano, S., Iino, M., Shige-yoshi, Y., Hashimoto, S., 2002. A transcription factor response element for gene transcription during circadian night. *Nature* 418, 534-539.

Ueyama, T., Krout, K.E., Nguyen, X.V., Karpitsky, V., Kollert, A., Mettenleiter, T.C., Loewy, A.D., 1999. Suprachiasmatic nucleus: a central autonomic clock. *Nat. Neurosci.* 2, 1051-1053.

Ulrich-Lai, Y.M., Arnhold, M.M., Engeland, W.C., 2006. Adrenal splanchnic innervation contributes to the diurnal rhythm of plasma corticosterone in rats by modulating adrenal sensitivity to ACTH. *Am. J. Physiol. Regul. Integr. Comp. Physiol.* 290, R1128-R1135.

Underwood, H., 1994. The circadian rhythm of thermoregulation in Japanese quail. I. Role of the eyes and pineal. *J. Comp. Physiol. A.* 175, 639-653.

Underwood, H., Barrett, R.K., Siopes, T., 1990. Melatonin does not link the eyes to the rest of the circadian system in quail: a neural pathway is involved. *J. Biol. Rhythms* 5, 349-361.

Uribe, C., 1926. On the biology and life history of *Rhodnius prolixus* (Stahl). *J. Parasitol.* 13, 129-136.

Ushirogawa, H., Abe, Y., Tomioka, K., 1997. Circadian locomotor rhythms in the cricket, *Gryllobates sigillatus*. II. Interactions between bilaterally paired circadian pacemakers. *Zoolog. Sci.* 14, 729-736.

Vafopoulou, X., Cardinal-Aucoin, M., Steel, C.G.H., 2012. Rhythmic release of prothoracicotrophic hormone from the brain of an adult insect during egg development. *Comp. Physiol. Biochem. Part A* 161, 193-200.

Vafopoulou, X., Steel, C.G.H., 1989. Developmental and diurnal changes in ecdysteroid biosynthesis by prothoracic glands of *Rhodnius prolixus* (Hemiptera) in vitro during the last larval instar. *Gen. Comp. Endocrinol.* 74, 484-493.

Vafopoulou, X., Steel, C.G.H., 1991. Circadian regulation of synthesis of ecdysteroids by prothoracic glands of the insect *Rhodnius prolixus*: evidence of a dual oscillator system. *Gen. Comp. Endocrinol.* 83, 27-34.

Vafopoulou, X., Steel, C.G.H., 1992. *In vitro* photosensitivity of ecdysteroid synthesis by prothoracic glands of *Rhodnius prolixus* (Hemiptera). *Gen. Comp. Endocrinol.* 89, 1-9.

Vafopoulou, X., Steel, C.G.H., 1993. Release in vitro of prothoracicotropic hormone from the brain of male *Rhodnius prolixus* during larval–adult development: identification of novel and predicted release times. *J. Insect Physiol.* 39, 65-71.

Vafopoulou, X., Steel, C.G.H., 1996a. The insect neuropeptide prothoracicotropic hormone is released with a daily rhythm: re-evaluation of its role in development. *Proc. Natl. Acad. Sci. USA* 93, 3368-3372.

Vafopoulou, X., Steel, C.G.H., 1996b. Circadian regulation of a daily rhythm of release of prothoracicotropic hormone from the brain–retrocerebral complex of *Rhodnius prolixus* (Hemiptera) during larval–adult development. *Gen. Comp. Endocrinol.* 102, 123-129.

Vafopoulou, X., Steel, C.G.H., 1997. Ecdysteroidogenic action of *Bombyx* prothoracicotropic hormone and bombyxin on the prothoracic glands of *Rhodnius prolixus in vitro*. *J. Insect Physiol.* 43, 651-656.

Vafopoulou, X., Steel, C.G.H., 1998. A photosensitive circadian oscillator in an insect endocrine gland: photic induction of rhythmic steroidogenesis *in vitro*. *J. Comp. Physiol.* A 182, 343-349.

Vafopoulou, X., Steel, C.G.H., 1999. Daily rhythm of responsiveness to prothoracicotrophic hormone in prothoracic glands of *Rhodnius prolixus*. Arch. Insect Biochem. Physiol. 41, 117-123.

Vafopoulou, X., Steel, C.G.H., 2001. Induction of rhythmicity in prothoracicotrophic hormone and ecdysteroids in *Rhodnius prolixus*: roles of photic and neuroendocrine Zeitgebers. J. Insect Physiol. 47, 935-941.

Vafopoulou, X., Steel, C.G.H., 2002. Prothoracicotrophic hormone of *Rhodnius prolixus*: partial characterization and rhythmic release of neuropeptides related to *Bombyx* PTTH and bombyxin. Invert. Reprod. Devel. 42, 11-120.

Vafopoulou, X., Steel, C.G.H., 2005. Testis ecdysiotropic peptides in *Rhodnius prolixus*: biological activity and distribution in the nervous system and testis. J. Insect Physiol. 51, 1227-1239.

Vafopoulou, X., Steel, C.G.H., 2006. Ecdysteroid hormone nuclear receptor (EcR) exhibits circadian cycling in certain tissues, but not others, during development in *Rhodnius prolixus* (Hemiptera). Cell Tissue Res. 323, 443-455.

Vafopoulou, X., Steel, C.G.H., 2009. Circadian organization of the endocrine system. In: Gilbert, L.I. (Ed.), Insect Development: Morphogenesis, Molting, and Metamorphosis.

Academic Press, London, pp. 395–458.

Vafopoulou, X., Steel, C.G.H., 2012a. Metamorphosis of a clock: remodelling of the circadian timing system in the brain of *Rhodnius prolixus* (Hemiptera) during larval-adult development. *J. Comp. Neurol.* 520, 1146-1164.

Vafopoulou, X., Steel, C.G.H., 2012b. Insulin-like and testis ecdysiotropin neuropeptides are regulated by the circadian timing system in the brain during larval-adult development in the insect *Rhodnius prolixus* (Hemiptera). *Gen. Comp. Endocr.* 179, 277-288.

Vafopoulou, X., Steel, C.G.H., 2012c. Cytoplasmic travels of the ecdysteroid receptor in target cells: pathways for both genomic and non-genomic actions. *Front. Endocrinol.* 3, 43.

Vafopoulou, X., Steel, C.G.H., 2014. Synergistic induction of the clock protein PERIOD by insulin-like peptide and prothoracicotrophic hormone in *Rhodnius prolixus* (Hemiptera): implications for convergence of hormone signaling pathways. *Front. Physiol.* 5, 41.

Vafopoulou, X., Steel, C.G.H., Terry, K.L., 2005. Ecdysteroid receptor (EcR) shows marked differences in temporal patterns between tissues during larval-adult development

in *Rhodnius prolixus*: correlations with haemolymph ecdysteroid titres. *J. Insect. Physiol.* 51, 27-38.

Vafopoulou, X., Steel, C.G.H., Terry, K.L., 2007. Neuroanatomical relations of prothoracicotrophic hormone neurons with the circadian timekeeping system in the brain of larval and adult *Rhodnius prolixus* (Hemiptera). *J. Comp. Neur.* 503, 511-524.

Vafopoulou, X., Terry, K.L., Steel, C.G.H., 2010. The circadian timing system in the brain of the fifth larval instar of *Rhodnius prolixus* (Hemiptera). *J. Comp. Neurol.* 518, 1264-1282.

Vallone, D., Frigaro, E., Vernesi, C., Foa, A., Foulkes, N.S., Bertolucci, C., 2007. Hypothermia modulates circadian clock gene expression in lizard peripheral tissues. *Am. J. Physiol. Regul. Integr. Comp. Physiol.* 292, R160-R166.

Van der Horst, G.T., Muijtjens, M., Kobayashi, K., Takano, R., Kanno, S., Takao, M., de Wit, J., Verkerk, A., Eker, A.P., van Leenen, D., Buijs, R., Bootsma, D., Hoeijmakers, J.H., Yasui, A., 1999. Mammalian Cry1 and Cry2 are essential for maintenance of circadian rhythms. *Nature* 398, 627-630.

Vandermissen, T., De Loof, A., Gu, S.-H., 2007. Both prothoracicotropic hormone and an autocrine factor are involved in control of prothoracic gland ecdysteroidogenesis in *Locusta migratoria* and *Schistocerca gregaria*. *Peptides* 28, 44-50.

Vanecek, J., Pavlik, A., Illnerova, H., 1987. Hypothalamic melatonin receptor sites revealed by autoradiography. *Brain Res.* 435, 359-362.

Van Wielendaele, P., Wynant, N., Dillen, S., Badisco, L., Marchal, E., Broeck, J.V., 2013. *In vivo* effect of Neuropeptide F on ecdysteroidogenesis in adult female desert locusts (*Schistocerca gregaria*). *J. Insect Physiol.* 59, 624-630.

Vatine, G., Vallone, D., Gothilf, Y., Foulkes, N.S., 2011. It's time to swim! Zebrafish and the circadian clock. *FEBS Letters* 585, 1485-1494.

Vaze, K.M., Sharma, V.K., 2013. On the adaptive significance of circadian clocks for their owners. *Chronobiol. Int.* 30, 413-433.

Veelaert, D., Schoofs, L., De Loof, A., 1998. Peptidergic control of the corpus cardiacum-corpora allata complex of locusts. *Int. Rev. Cytol.* 182, 249-302.

Vitaterna M.H., King, D., Chang, A., Kornhauser, J.M., Lowrey, P.L., McDonald, J.D., Dove, W.F., Pinto, L.H., Turek, F.W., Takahashi, J.S., 1994. Mutagenesis and mapping of a mouse gene clock, essential for circadian behaviour. *Science* 264, 719-725.

Vosshall, L.B., Price, J.L., Sehgal, A., Saez, L., Young, M.W., 1994. Block in nuclear localization of period protein by a second clock mutation, timeless. *Science* 263, 1606-1609.

Watanabe, N., Itoh, K., Mogi, M., Fujinami, Y., Shimizu, D., Hashimoto, H., Uji, Susumu, Yokoi, H., Suzuki, T., 2012. Circadian pacemaker in the suprachiasmatic nuclei of teleost fish revealed by rhythmic period2 expression. *Gen. Comp. Endocrinol.* 178, 400-407.

Weaver, R.J., Audsley, N., 2009. Neuropeptide regulators of juvenile hormone synthesis: structures, functions, distribution, and unanswered questions. *Ann. NY Acad. Sci.* 1163, 316-329.

Weaver, R.J. Strambi, A., Strambi, C., 1984. The significance of free ecdysteroids in the haemolymph of adult cockroaches. *J. Insect Physiol.* 30, 705-711.

Weber, F., 1995. Cyclic layer deposition in the cockroach (*Blaberus cranifer*) endocuticle: a circadian rhythm in leg pieces cultured *in vitro*. J. Insect Physiol. 41, 153-161.

Weber, F., 2009. Remodeling the clock: coactivators and signal transduction in the circadian clockworks. Naturwissenschaften 96, 321-337.

Welsh, D.K., Logothetis, D.E., Meister, M., Reppert, S.M., 1995. Individual neurons dissociated from rat suprachiasmatic nucleus express independently phased circadian firing rhythms. Neuron 14, 697-706.

Welsh, D. K., Yoo, S. H., Lui, A. C., Takahashi, J. S., Kay, S.A., 2004. Bioluminescence imaging reveals persistent, independently phased circadian rhythms of clock gene expression. Curr. Biol. 14, 2289-2295.

Wen, H.W., Lee, H.J., 2000. Unequal coupling between locomotor pacemakers of the German cockroach, *Blattella germanica* (L.). J. Insect Physiol. 46, 89-97.

Went, F.W., 1960. Photo-periodic and thermoperiodic effects in plant growth. Cold Spring Harbor Symp. Quant. Biol. 25, 221-230.

Westbrook, A.L., Regan, S.A., Bollenbacher, W.E., 1993. Developmental Expression of the Prothoracicotropic Hormone in the CNS of the Tobacco Hornworm *Manduca sexta*. J. Comp. Neurol. 327, 1-16.

Whitehead, K., Pan, M., Masumura, K., Bonneau, R., Baliga, N., 2009. Diurnally entrained anticipatory behavior in Archaea. PLoS One 4, e5485.

Whitmore, D., Foulkes, N.S., Strähle, U., Sassone-Corsi, P., 1998. Zebrafish *clock* rhythmic expression reveals independent peripheral circadian oscillators. Nat. Neurosci. 1, 701-707.

Wiedenmann, G., 1983. Splitting in a circadian activity rhythm: the expression of bilaterally paired oscillators. J. Comp. Physiol. 150, 51-60.

Wigglesworth, V.B., 1934. The physiology of ecdysis in *Rhodnius prolixus* (Hemiptera) II. Factors controlling molting and "metamorphosis." Quart. J. Mic. Sci. 77, 191-222.

Wigglesworth, V.B., 1936. The function of the corpus allatum in the growth and reproduction of *Rhodnius prolixus* (Hemiptera). Quart. J. Mic. Sci. 79, 91-121.

Wigglesworth, V.B., 1939. Häutung bei Imagines von Wanzen. Naturwissenschaften 27, 301.

- Wigglesworth, V.B., 1940. The determination of characters at metamorphosis in *Rhodnius prolixus* (Hemiptera). J. Exp. Biol. 17, 201-222.
- Wigglesworth, V.B., 1948. The function of the corpus allatum in *Rhodnius prolixus* (Hemiptera). J. Exp. Biol. 25, 1-14.
- Wigglesworth, V.B., 1952. The thoracic gland in *Rhodnius prolixus* (Hemiptera) and its role in moulting. J. Exp. Biol. 29, 561-570.
- Wigglesworth, V.B., 1961. Some observations on the juvenile hormone effect of farnesol in *Rhodnius prolixus* Stal. (Hemiptera). J. Insect Physiol. 7, 73-78.
- Williams, C.M., 1947. Physiology of insect diapause II. Interaction between the pupal brain and prothoracic glands in the metamorphosis of the giant silkworm, *Platysamia cercropia*. Biol. Bull. 93, 89-98.
- Williams, C.M., 1956. The juvenile hormone of insects. Nature 178, 212-213.
- Wilps, H., Zöller, T., 1989. Origin of ecdysteroids in females of the blowfly *Phormia terranovae* and their relation to reproduction and energy metabolism. J. Insect Physiol. 35, 709-717.

Woolum, J.C., 1991. A re-examination of the role of the nucleus in generating the circadian rhythm in *Acetabularia*. *J. Biol. Rhythms* 6, 129-136.

Wyatt, G.R., Davey, K.G., 1996. Cellular and molecular actions of juvenile hormone. II. Roles of juvenile hormones in adult insects. *Adv. Insect Physiol.* 26, 1-155.

Wu, Q., Brown, M.R., 2006. Signaling and function of insulin-like peptides in insects. *Ann. Rev. Entomol.* 51, 1-24.

Xu, K., Zheng, X., Sehgal, A., 2008. Regulation of feeding and metabolism by neuronal and peripheral clocks in *Drosophila*. *Cell Metab.* 8, 289-300.

Yamaguchi, S., Isejima, H., Matsuo, T., Okura, R., Yagita, K., Kobayashi, M., Okamura, H., 2003. Synchronization of cellular clocks in the suprachiasmatic nucleus. *Science* 302, 1408-1412.

Yamamoto, T., Nakahata, Y., Tanaka, M., Yoshida, M., Soma, H., Shinohara, K., Yasuda, A., Mamime, T., Takumi, T., 2005. Acute physical stress elevates mouse period1 mRNA expression in mouse peripheral tissues via a glucocorticoid-responsive element. *J Biol. Chem.* 280, 42036-42043.

Yamanaka, N., Hua, Y.-J., Mizoguchi, A., Watanabe, K., Niya, R., Tanaka, Y., Kataoka, H., 2005. Identification of a novel prothoracicostatic hormone and its receptor in the silkworm *Bombyx mori*. *J. Biol. Chem.* 280, 14684-14690.

Yamanaka, N., Žitňan, D., Kim, Y.-J., Adams, M.E., Hua, Y.-J., Suzuki, Y., Suzuki, M., Suzuki, A., Satake, H., Mizoguchi, A., Asaoka, K., Tanaka, Y., Kataoka, H., 2006. Regulation of insect steroid hormone biosynthesis by innervating peptidergic neurons. *Proc. Natl Acad. Sci. USA* 103, 8622-8627.

Yamazaki, S., Numano, R., Abe, M., Hida, A., Takahashi, R., Ueda, M., Block, G.D., Sakaki, Y., Menaker, M., 2000. Resetting central and peripheral circadian oscillators in transgenic rats. *Science* 288, 682-685.

Yang, X., Downes, M., Yu, R.T., Bookout, A.L., He, W., Straume, M., Mangelsdorf, D.J., Evans, R.M., 2006. Nuclear receptor expression links the circadian clock to metabolism. *Cell* 126, 801-810.

Yerushalmi, S., Green, R.M., 2009. Evidence for the adaptive significance of circadian rhythms. *Eco. Letters* 12, 970-981.

Yin, L., Wu, N., Curtin, J.C., Qatanani, M., Szwegold, N.R., Reid, R.A., Waitt, G.M., Parks, D.J., Pearce, K.H., Wisely, G.B., Lazar, M.A., 2007. Rev-erba, a heme sensor that coordinates metabolic and circadian pathways. *Science* 318, 1786-1789.

Young, S.-C., Yeh, W.-L., Gu, S.-H., 2012. Transcriptional regulation of the PTTH receptor in prothoracic glands of the silkworm, *Bombyx mori*. *J. Insect Physiol.* 58, 102-109.

Yoshikawa, T., Sellix, M., Pezuk, P., Menaker, M., 2009. Timing of the ovarian circadian clock is regulated by gonadotropins. *Endocrinol.* 150, 4338-4347.

Yuan, Q., Metterville, D., Briscoe, A.D., Reppert, S.M., 2007. Insect cryptochromes: gene duplication and loss define diverse ways to construct insect circadian clocks. *Mol. Biol. Evol.* 24, 948-955.

Zantke, J., Ishikawa-Fujiwara, T., Arboleda, E., Lohs, C., Schipany, K., Hallay, N., Straw, A.D., Todo, T., Tessmar-Raible, K., 2013. Circadian and circalunar clock interactions in a marine annelid. *Cell Reports* 5, 1-15.

Zera, A.J., Zhao, Z., 2009. Morph-associated JH titer diel rhythm in *Gryllus firmus*: experimental verification of its circadian basis and cycle characterization in artificially selected lines raised in the field. *J. Insect Physiol.* 55, 450-458.

Zerr, D.M., Hall, J.C., Rosbash, M., Siwicki, K.K., 1990. Circadian fluctuations of period protein immunoreactivity in the CNS and the visual system of *Drosophila*. *J. Neurosci.* 10, 2749-2762.

Zhang, Q., Denlinger, D.L., 2011. Molecular structure of the prothoracicotropic hormone gene in the northern house mosquito, *Culex pipiens*, and its expression analysis in association with diapause and blood feeding. *Insect Mol. Biol.* 20, 201-213.

Zhang, L., Hastings, M.H., Green, E.W., Tauber, E., Sladek, M., Webster, S.G., Kyriacou, C.P., Wilcockson, D.C., 2013. Dissociation of circadian and circatidal timekeeping in the marine crustacean *Eurydice pulchra*. *Curr. Biol.* 23, 1-11.

Zhao, Z., Zera, A.J., 2004. A morph-specific daily cycle in the rate of JH biosynthesis underlies a morph-specific daily cycle in the hemolymph JH titer in a wing-polymorphic cricket. *J. Insect Physiol.* 50, 965-973.

Zheng, X., Sehgal, A., 2012. Speed control: cogs and gears that drive the circadian clock. *Trends Neurosci.* 35, 574-585.

Zhou, X., Yuan, C., Guo, A., 2005. *Drosophila* olfactory response rhythms require clock genes but not pigment dispersing factor or lateral neurons. *J Biol. Rhythms* 20, 237-244.

- Zhu, X.X., Gfeller, H., Lanzrein, B., 1983. Ecdysteroids during oogenesis in the ovoviviparous cockroach *Nauphoeta cinerea*. *J. Insect Physiol.* 29, 225-235.
- Zhu, H., Sauman, I., Yuan, Q., Casselman, A., Emery-Le, M., Emery, P., Reppert, S.M., 2008. Cryptochromes define a novel circadian clock mechanism in monarch butterflies that may underlie sun compass navigation. *PLoS Biol* 6, e4.
- Zhu, H., Yuan, Q., Froy, O., Casselman, A., Reppert, S.M., 2005. The two CRYs of the butterfly. *Curr. Biol.* 15, R954.
- Zimmerman, N.H., Menaker, M., 1979. The pineal gland: a pacemaker within the circadian system of the house sparrow. *Proc. Natl Acad. Sci. USA* 76, 999-1003.
- Zinn, J.G., 1759. Von dem Schlafe der Pflanzen. *Hamburg. Mag.* 22, 40-50.
- Žitňan, D., Sehnal, F., Bryant, P.J., 1993. Neurons producing specific neuropeptides in the central nervous system of normal and pupariation-delayed *Drosophila*. *Devel. Biol.* 156, 117-135.
- Žitňan, D., Kim, Y.-J., Žitňanová, I., Roller, L., Adams, M.E., 2007. Complex steroid-peptide-receptor cascade controls insect ecdysis. *Gen. Comp. Endocr.* 153, 88-96.