

**DEVELOPMENT OF HIGH EFFICIENCY PARTIAL  
NITRIFICATION AS A FIRST STEP OF NITRITE SHUNT  
PROCESS USING AMMONIUM-OXIDIZING BACTERIA  
(AOB)**

**MOOMEN MAHMOUD MOHARRAM SOLIMAN**

A THESIS SUBMITTED TO THE FACULTY OF GRADUATE STUDIES IN  
PARTIAL FULFILLMENT OF THE REQUIREMENTS FOR THE DEGREE  
OF  
MASTER OF APPLIED SCIENCE

GRADUATE PROGRAM  
IN  
CIVIL ENGINEERING

**YORK UNIVERSITY, TORONTO, ONTARIO**

**DECEMBER 2016**

© Moomen Soliman, 2016

## ABSTRACT

Fresh water represents only less than 1% of global water volume with only 1% of this volume constituted of lakes and river, thus protecting the aquatic ecosystems from human manipulation is a key feature towards sustainability. Hence, enhancing the quality of the wastewater treatment plants (WWTPs) effluent discharged in these ecosystems has gained broad interest in the last decades especially in terms of nutrient. Shortcut Biological Nitrogen Removal (SBNR) which is a non-conventional way of removing nitrogen from wastewater using two processes either nitrite shunt or deammonification have been adopted to reduce the nitrogenous compounds in the effluent of WWTPs.

In this research, a complete partial nitrification as a first step of the Nitrite Shunt process has been developed under a high nitrogen loading rate (NLR) using a novel strategy to control the DO depending on using a constant air flow rate with a variable mixing speed in a suspended growth system using a Sequential Batch Reactor (SBR). The SBR was operated with a stepwise increase in influent ammonium concentration reaching a concentration of 1000 mg  $\text{NH}_3\text{-N/L}$  at NLR of 1.2 kg/ ( $\text{m}^3\cdot\text{d}$ ) maintaining an ammonia removal efficiency (ARE) of  $98.6 \pm 2.8\%$  with nitrite accumulation rate (NAR) of  $93.0 \pm 0.7\%$ , which is 2 times higher than the previous NLR reported in the literature. Moreover, a dynamic and pseudo-state model of partial nitrification has been developed and calibrated using BioWin software for long-term dynamic behavior of the lab-scale SBR at different nitrogen loading rates (NLR).

## **ACKNOWLEDGMENT**

Firstly, I would like to thank ALLAH, the Almighty, the Most Gracious and the Most Merciful who empowered me with strength and knowledge to accomplish this work.

I would like to express my sincere gratitude to my advisor Prof. Ahmed EIDyasti for his continuous support, valuable advices, patience, motivation, and immense knowledge. His guidance helped me in all the time of research and writing of this thesis. I could not have imagined having a better advisor and mentor for my Master's study. I would like to thank my fellow colleagues in our research team, Ahmed Fergala, Ahmed ElSayed, Mahmoud Mansour, Parin Izadi and Parnian Izadi for the stimulating discussions we had, for their encouragement and their help during lab work as well as my friends Ahmed Adel, Nader, Zaki, Abdelhameed, Khaled and Waleed for the sleepless nights we were working together before deadlines, and for all the fun we have had in the last two years.

Lastly, no words can describe my gratitude and appreciation to my parents, brothers and wife without whom I would not have reached this point. My father, my role model who inspired me towards engineering career. My mother for her endless prayers and unbounded love and encouragement. My brothers Mostafa and Marwan for their continuous support. My beloved wife Rana, who sacrificed a lot for me, for her endless love, support, encouragement and kind understanding.

# Table of Contents

Abstract .....	ii
Acknowledgment .....	iii
List of Tables .....	viii
List of Figures .....	x
Acronyms .....	xii
CHAPTER 1 Introduction.....	1
1.1 Background.....	1
1.2 Problem Statement .....	3
1.3 Objectives .....	5
1.4 Thesis Layout .....	6
1.5 Thesis Contribution .....	7
CHAPTER 2 Literature Review .....	9
2.1 Introduction .....	9
2.2 Aerobic AOBs Microbial Characteristics .....	10
2.2.1 AOB's Phylogeny .....	10

2.2.2	AOB's Morphology .....	11
2.2.3	AOB's ecophysiology .....	12
2.2.4	AOB's Physiology .....	18
2.2.5	AOB's Enzymology.....	20
2.2.6	AOB's Kinetics.....	22
2.3	Parameters affecting AOB.....	26
2.3.1	Dissolved Oxygen Concentration .....	26
2.3.2	Temperature .....	30
2.3.3	pH, free ammonia (FA) and free nitrous acid (FNA) .....	31
2.3.4	HRT and SRT .....	33
2.4	Suspended Partial Nitrification Technologies.....	35
2.4.1	Sequential Batch Reactor (SBR).....	35
2.4.2	Continuous Stirred Tank Reactor (CSTR).....	41
2.4.3	Single reactor for high activity ammonia removal over nitrite (SHARON).....	44
2.4.4	Novel Systems .....	46
2.5	Attached Partial Nitrification Technologies.....	50
2.5.1	Biofilm processes.....	52

2.5.2	Granular processes .....	66
CHAPTER 3	Development of Partial Nitrification as a first step of Nitrite Shunt process in a SBR using AOB through DO limitations conditions controlled by mixing regime* .....	71
3.1	Introduction .....	71
3.2	Materials and Methods .....	75
3.2.1	Reactor design.....	75
3.2.2	Operational Conditions .....	78
3.2.3	Feeding solution and seeding sludge .....	79
3.2.4	Analytical Methods .....	81
3.2.5	Molecular techniques .....	82
3.3	Results and discussions .....	83
3.3.1	SBR performance.....	83
3.3.2	Factors affecting SBR partial nitrification performance .....	91
3.3.3	PCR identification.....	101
3.4.	Conclusions .....	103
CHAPTER 4	Long-term Dynamic and Pseudo-State Modeling of Complete Partial Nitrification Process at high nitrogen loading rates in a SBR* .....	104

4.1	Introduction .....	104
4.2	Materials and Methods .....	109
4.2.1	Experimental SBR .....	109
4.2.2	SBR Model.....	110
4.2.3	SBR calibration protocol .....	111
4.3	Results and discussions .....	116
4.3.1	Identifiability analysis.....	116
4.3.2	Model Calibration .....	118
4.3.3	Model validation and data evaluation.....	121
4.4	Conclusions .....	130
CHAPTER 5	Conclusions and Future Work .....	131
5.1	Conclusions .....	131
5.2	Direction of Future work.....	133
	Bibliography.....	135

# LIST OF TABLES

Table 2-1: Summary of reported AOB kinetic parameters.....	24
Table 2-2: Summary of reported NOB kinetic parameters.....	25
Table 3-1: Ammonia removal efficiency and nitrite accumulation rate in Partial nitrification SBRs.....	74
Table 3-2: a) Detailed operational conditions during different stages of the SBR, (b) Influent characteristics for Synthetic municipal wastewater (SMW) and (c) Primer sets included in PCR assay .....	80
Table 3-3: Summary of Partial Nitrification SBR performance during all different stages .....	86
Table 4-1: Normalized sensitivity coefficient ( $S_{i, j}$ ) of effluent characteristics of kinetic and stoichiometric parameters .....	116
Table 4-2: Mean square sensitivity measure ( $\delta_{jmsqr}$ ) ranking of kinetic and stoichiometric parameters .....	117
Table 4-3: Comparison between the default, literature and calibrated values for the selected kinetics and stoichiometric parameters used in BioWin® .....	120
Table 4-4: Comparison between pseudo-stable-state influent and effluent characteristics of the experimental SBR, SBR model after calibration and SBR model before calibration .....	121

Table 4-5: Comparison between the average effluent data obtained in the experimental SBR and predicted by the model during the different operational stages .....125

# LIST OF FIGURES

Figure 1-1: Comparison between conventional and shortcut nitrogen removal over the nitrogen cycle .....	3
Figure 2-1: Morphological and Eco-physiological Characteristics of reported Ammonia Oxidizing Bacteria's species.....	17
Figure 2-2: Electron transport pathways in AOB .....	22
Figure 2-3: Performance of Partial nitrification suspended systems during different DO concentrations in terms of: (a) Nitrite accumulation rate (NAR); (b) Ammonia removal efficiency (ARE).....	29
Figure 2-4: SBR cycle duration for different partial nitrification studies .....	41
Figure 2-5: Biofilm reactor configurations. (a) MBR; (b) MBBR; (c) BAS.....	53
Figure 3-1: (a) Schematic Diagram of the SBR used in this experiment; (b) BioFlo® 115 Benchtop Fermenter & Bioreactor during operation; (c) SBR's cycle for Partial Nitrification process.....	77
Figure 3-2: SBR Nitrogen removal performance during the three stages of operation: (a) Ammonia Removal Efficiency (ARE) and Nitrite Accumulation rate (NAR) during different NLR; (b) Influent and Effluent NH <sub>3</sub> -N concentrations and ammonia removal efficiency; (c) NO <sub>2</sub> -N and NO <sub>3</sub> -N concentrations in the effluent and NAR (%) .....	90

Figure 3-3: Typical profile for: (a) influent alkalinity concentrations, effluent alkalinity concentrations and pH, (b) oxidized ammonia to alkalinity consumed molar ratio, and (c) free ammonia (FA) and free nitrous acid (FNA) .....97

Figure 3-4: PCR products using genomic DNA of sample 1 and 2 with the five sets of primers. ....102

Figure 4-1: BioWin<sup>®</sup> schematic diagram of SBR model.....111

Figure 4-2: Correlation between model and measured effluent parameters for: (a) pH, (b) alkalinity, (c) nitrite, (d) nitrate (Note: vertical and horizontal error bars represent the standard deviations for the measured and model results, respectively) .....124

Figure 4-3: Comparison between experimental and model data during different Nitrogen loading levels (NLR) in terms of: (a) Ammonia removal efficiency (ARE), (b) Nitrite accumulation rate (NAR) .....127

Figure 4-4: Comparison between daily effluent measured and dynamic model data for: (a) Nitrite concentrations; (b) nitrate concentrations; (c) pH.....129

# ACRONYMS

<b>AMO</b>	Ammonia Monooxygenase
<b>ANAMMOX</b>	Anaerobic Ammonium-Oxidizing Bacteria
<b>AOB</b>	Ammonium-Oxidizing Bacteria
<b>ARE</b>	Ammonia Removal Efficiency
<b>BAS</b>	Biofilm Airlift Suspension
<b>BNR</b>	Biological Nitrogen Removal
<b>COD</b>	Chemical Oxygen Demand
<b>CSTR</b>	Continuous Stirred Tanks Reactors
<b>DGGE</b>	Denaturing Gradient Gel Electrophoresis
<b>DO</b>	Dissolved Oxygen
<b>FA</b>	Free Ammonia
<b>FBBR</b>	Fluidized Bed Bioreactor
<b>FISH</b>	Fluorescence In Situ Hybridization
<b>FNA</b>	Free Nitrous Acid

<b>HAO</b>	Hydroxylamine Oxidoreductase
<b>HRT</b>	Hydraulic Retention Time
<b>MBBR</b>	Moving Bed Biofilm Reactor
<b>MBR</b>	Membrane Bioreactor
<b>NAR</b>	Nitrite Accumulation Rate
<b>NLR</b>	Nitrogen Loading Rate
<b>NOB</b>	Nitrite-Oxidizing Bacteria
<b>PN</b>	Partial Nitrification
<b>PCR</b>	Polymerase Chain Reaction
<b>qPCR</b>	Quantitative Polymerase Chain Reaction
<b>SBNR</b>	Shortcut Biological Nitrogen Removal
<b>SBR</b>	Sequential Batch Reactors
<b>SHARON</b>	Single reactor for High activity Ammonia Removal Over Nitrite
<b>SRT</b>	Solids Retention Time
<b>WWTPs</b>	WasteWater Treatment Plants

$\mu_{\max}$	Maximum growth rate
$b_{\text{aerobic}}$	Aerobic decay rate
$K_{\text{NH}_4}$	Substrate ( $\text{NH}_4$ ) half saturation constant
$K_0$	Oxygen half saturation constant
$Y$	Yield
$K_{\text{NO}_2}$	Substrate ( $\text{NO}_2$ ) half saturation constant
$K_{\text{iHNO}_2}$	AOB Nitrous acid inhibition
$K_{\text{iNH}_3}$	NOB Ammonia inhibition concentration
$S_{i,j}$	The normalized sensitivity coefficient
$\delta_j^{\text{msqr}}$	The mean square sensitivity measure

# CHAPTER 1

## INTRODUCTION

### 1.1 Background

The excessive nitrogenous compounds from the effluent of wastewater treatment plants withdrawn in lakes or other natural water cause numerous problems for the aquatic system as it leads to eutrophication causing the excessive growth of algae and increase in the oxygen depletion and poisons in the aquatic life. Due to its higher efficiency and lower cost over physical-chemical processes, Biological Nitrogen Removal (BNR) processes have been adopted widely to avoid the eutrophication and reduce the growth of algae. Conventional BNR processes comprise two main practices: nitrification and denitrification. Nitrification is the aerobic biological conversion of ammonia to nitrate with oxygen as electron acceptor via a group of autotrophic bacteria through two steps involving Ammonium-Oxidizing Bacteria (AOB) and Nitrite-oxidizing Bacteria (NOB), respectively. However, these two steps conventional BNR processes require 2 moles of oxygen and organic matter to oxidize the ammonia to nitrate and later to nitrogen gas.

Hence, conventional BNR processes require high oxygen and external carbon sources along with a slow growth of the autotrophic and heterotrophic bacteria. To reduce the energy required for nitrogen removal as well as improve the nitrogen

removal of side stream high ammonia waste streams, Shortcut Biological Nitrogen Removal (SBNR) has been developed. Based on the fact that nitrite is an intermediate compound in both nitrification and denitrification, SBNR relies on the direct conversion of nitrite produced in the first step of nitrification to atmospheric nitrogen instead of oxidizing it to nitrate then reducing the latter back to the former. Shortcut Biological Nitrogen Removal implies the reduction of oxygen consumption during the aerobic phase by 25% as a result of skipping the nitrite oxidation to nitrate and consequently reduces the total energy required by 60% [1]. Additionally, SBNR eliminates the use of external electron donor by 40%; resulting from skipping the nitrate reduction to nitrite; which makes it suitable for wastewater with low carbon to nitrogen ratio. Shortcut Biological Nitrogen Removal also results in a significant decrease of the sludge production in nitrification and denitrification processes by 35% and 55%, respectively [1].

The SBNR process comprises both nitrite shunt and deammonification processes. In the deammonification process, 50% of the ammonia is oxidized to nitrite subsequently the remaining ammonia is oxidized anaerobically to nitrogen gas using the nitrite produced as electron acceptor carried out by Anaerobic Ammonium-Oxidizing (Anammox) bacteria. On the other hand, nitrite shunt stimulates the first step of nitrification (nitritation) and inhibits the second step of

the oxidation of nitrite (partial nitrification), and then denitrifies nitrite directly to nitrogen gas as shown in **Figure 1-1**.

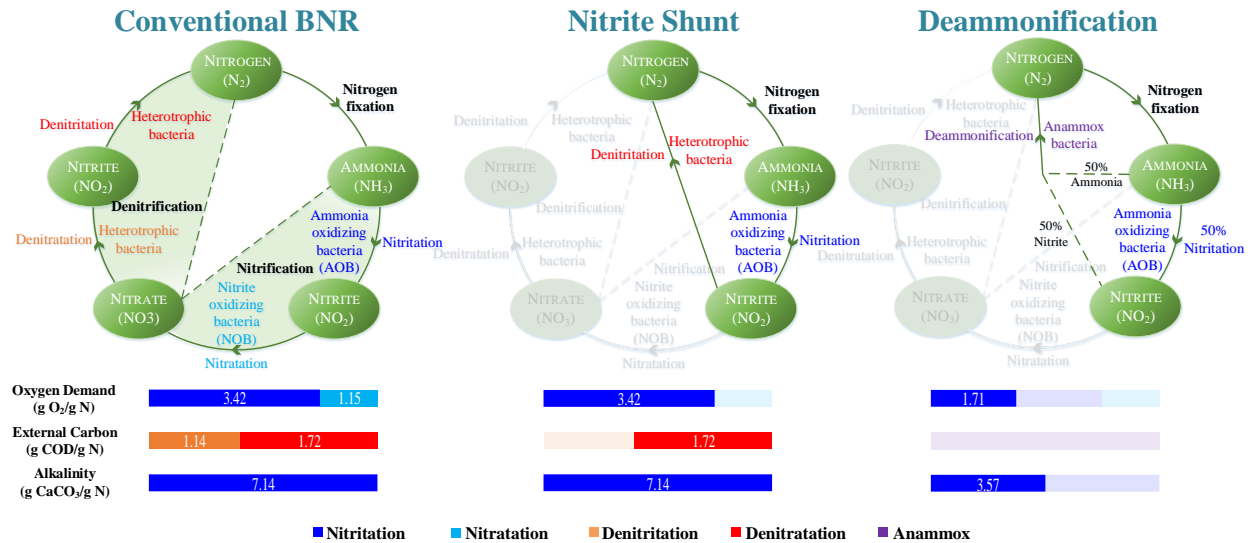

**Figure 1-1: Comparison between conventional and shortcut nitrogen removal over the nitrogen cycle**

## 1.2 Problem Statement

Recently, partial nitrification has been adopted widely either for the nitrite shunt process or intermediate nitrite generation step for the Anammox process. However, it is noteworthy that the majority of the studies in the literature have targeted to achieve an effluent of  $\text{NO}_2:\text{NH}_4$  molar ratio of 1.31 suitable for subsequent Anammox process [2] with limited studies targeting to reach a complete oxidation of ammonia to nitrite (complete partial nitrification) as a first step for the nitrite shunt process. Moreover, achieving complete partial nitrification has been hindered by the destruction of nitrite accumulation at high nitrogen loading rate

(NLR), which affects the feasibility of the process for wastewater with high nitrogen content [3].

Furthermore, in order to achieve nitrite accumulation and selectively inhibit NOB, several strategies has been developed and used including (i) maintaining low dissolved oxygen concentration, (ii) controlling free ammonia (FA) and free nitrous acid (FNA) concentrations through temperature/pH, and (iii) reducing the hydraulic retention time (HRT) [3]–[5]. Notwithstanding that DO limitation conditions are considered being the most feasible strategy for sustainable partial nitrification, it remains a challenge maintaining a specific DO concentration during the whole process otherwise a slight increase in the DO concentrations might diminish the nitrite accumulation. Additionally, slow mixing speed accompanied with low aeration requirements for DO control could result in some biomass settling during the reaction time.

Moreover, partial nitrification has been performed using different reactors configurations including suspended growth systems such as continuous stirred tanks reactors (CSTR), sequential batch reactors (SBR) and single reactor for high activity ammonia removal over nitrite (SHARON) or attached growth systems such as Membrane bioreactor (MBR), Moving Bed Biofilm reactors (MBBR) and Biofilm Airlift Suspension (BAS) [6]–[11]. However, SBRs have shown great success in achieving nitrite accumulation at high nitrogen loading rates due to its discontinuous

feeding which allows the reactor to maintain high ammonia concentration as well as the sequencing of the feeding phase would help to control possible FA and FNA accumulations inside the reactor and by consequence inhibiting NOB.

On the other hand, an important step to facilitate the scale-up of these partial nitrification SBRs at high NLR is the development of a *process model* for dynamic and pseudo-state conditions. The success of these models is defined by their ability to predict the dynamic behavior of the experimental SBR used for simulation, thus a precedent calibration step might be needed for the model to accurately fit the experimental data obtained. However, most studies on SBR modeling were evaluated considering only the short time dynamics (cycle based dynamics model) by simulating the reactor behavior during specific SBR cycles and; up until now; no models are readily available that can accurately predict the long-term dynamic behavior of partial nitrification SBRs [12]–[15].

### **1.3 Objectives**

In this research, the development of partial nitrification process and process model were undertaken. The specific objectives of this research are:

- Achieving stable complete partial nitrification with high ammonia removal efficiency and nitrite accumulation rate as a first step of the Nitrite Shunt process.

- Overcoming the reported problem of destruction of stable partial nitrification at high NLR.
- Developing a new strategy for maintaining DO concentrations at the required range while avoiding any biomass settling during the reaction time.
- Evaluating the factors affecting stable partial nitrification performance.
- Developing a model to describe the long-term dynamic behavior of partial nitrification
- Introducing a new step in the calibration protocols to eliminate the needs of the respirometric analysis for SBR models.
- Identifying the most influential kinetic and stoichiometric parameters on rapid shift from complete to partial nitrification.

## **1.4 Thesis Layout**

This thesis comprises five chapters. After an introduction in the first chapter, a comprehensive literature review including the microbial characteristics and kinetics parameters of AOB, the optimum values of the main parameters that can selectively inhibits NOB growth or allow AOB to outcompete NOB as well as successful reported partial nitrification studies in suspended and attached growth systems is presented in Chapter 2.

In Chapter 3, the detailed description of the materials and methodology of the experimental SBR used to achieve high efficiency complete partial nitrification as a first step of the nitrite shunt process is provided. Additionally, the SBR performance results are presented and discussed as well the different parameters affecting partial nitrification performance are evaluated.

Chapter 4 focuses on the modelling and simulation of partial nitrification using the operational data of the lab SBR by the software BioWin (EnviroSim Associates Ltd., Flamborough, Ontario, Canada), which is widely used for modeling wastewater treatment plants. The detailed steps for the model calibration and validation are described as well the results and the coloration between the model and the measured data are discussed.

Finally, chapter 5 compiles the major findings of this study and the direction of future work.

## **1.5 Thesis Contribution**

This study provides an insight into partial nitrification as the first step of Nitrite Shunt process to significantly reduce the oxygen and organic carbon sources for BNR systems. This study aimed at reaching a stable partial nitrification at a high nitrogen-loading rate (NLR) using DO limitation conditions as main inhibition strategy for nitrate production. A novel strategy for DO control has been developed

in a SBR to overcome the challenges facing the partial nitrification process. The novel strategy depends on using a constant air flow rate with a variable mixing speed according to the DO concentrations inside the reactor to maintain the required DO for the whole operation period while assuring that the agitation is always working at the maximum available speed and by consequence preventing any biomass settling during the reaction time. Moreover, a feeding strategy depending on a stepwise increase in ammonia concentrations has been applied to allow the biomass to adapt gradually to each NLR and reach its maximum performance consequently preventing any shock effect on the biomass to overcome the destruction of stable partial nitrification at high NLR. Furthermore, the proposed model is an important step to facilitate the scale-up of these partial nitrification SBRs at high NLR.

# CHAPTER 2

## LITERATURE REVIEW

### 2.1 Introduction

Effective nitrite shunt process relies on suppressing the second step of nitrification which is the nitrite oxidation to nitrate without having an inhibitory effect on the former ammonia oxidation rate known as partial nitrification process. Hence, Successful partial nitrification could be achieved by accumulating AOB and inhibiting NOB. AOB accumulation depends upon the knowledge of their microbial characteristics and kinetics parameters as well as the main parameters that can selectively inhibits NOBs' growth or allow AOBs to outcompete them. These parameters may include appropriate regulation of the reactor's dissolved oxygen concentration (DO), temperature, pH, hydraulic retention time (HRT), solids retention time (SRT), alkalinity as well as the presence of free ammonia.

Moreover, numerous bioreactors configurations has been used towards achieving partial nitrification in wastewater treatment plants each comprising several advantages as well as some drawbacks. These biological systems are either based on suspended growth technologies where bacteria are grown in flocs which refer to an assemblage of individual cells or micro colonies that take place in a reactor under particular conditions or after the addition of an agent to the medium [16] or attached growth technologies where bacteria are grown in biofilm which is a

complex coherent structure of cells and cellular products which can grow as large, dense granules or attached on a static solid surface or attached on to suspended carriers [17].

Thus, this chapter aims to explore the microbial characteristics and kinetics parameters of AOB as well as investigating the optimum values of the main parameters that can selectively inhibits NOB growth or allow AOB to outcompete NOB. Moreover, suspended and attached partial nitrification systems have been complied.

## **2.2 Aerobic AOBs Microbial Characteristics**

### **2.2.1 AOB's Phylogeny**

Since the first AOB isolation in 1890, numerous studies have been performed to identify their phylogenetic diversity [18], [19]. As a result for these efforts, five AOB genera have been recognized and classified in the Proteobacteria class. Four of which lies in the  $\beta$ - Proteobacteria subclass including *Nitrosomonas* (including *Nitrosococcus mobilis*), *Nitrospira*, *Nitrosovibrio* and *Nitrosolobus*, while one cluster of *Nitrosococcus* belongs within the  $\gamma$ - Proteobacteria subclass.

However, the investigation of AOB enumeration, diversity and abundance in engineering systems or their natural environments remained a complex process using the conventional culture-dependent technique due to the complexity and long period

accompanied with the cultivation of these microorganisms- till the evolution of culture independent molecular techniques [20]. Furthermore, the culture dependent methods are thought to underrate the actual cell numbers due to potential defective cell suspension or disturbance in flasks and microcolonies or some cell damage [21]. On the other hand, the development of culture independent molecular methods like fluorescence in situ hybridization (FISH), polymerase chain reaction (PCR), quantitative PCR (qPCR), denaturing gradient gel electrophoresis (DGGE) and Quinone profile techniques has allowed an accurate detection and identification of AOB communities.

### **2.2.2 AOB's Morphology**

The morphological diversity of AOB can be classified into four main categories: cell shape, cell size, flagellation of motile cells, and arrangement of intracytoplasmic membranes as shown in **Figure 2-1**. These categories vary from one cluster to another ranging from straight rods cells with polar to subpolar motile cells having Peripheral flattened vesicles with cell size of (0.7-1.5 x 1.0-2.4  $\mu\text{m}$ ) for *Nitrosomonas* clusters to (1.5-1.8 x 1.7-2.5)  $\mu\text{m}$  spherical ellipsoidal cells with Tuft of flagella for motility having Peripheral or central stacks of vesicles observed in *Nitrosococcus*. On the other hand, *Nitrospira* species are reported to be tightly coiled spirals with Peritrichous motile cells having Invaginations in the intracytoplasmic membranes with cell size of (0.3-0.8 x 1.0-8.0)  $\mu\text{m}$ , while,

*Nitrosolobus* species are reported to be Pleomorphic lobate cells with Peritrichous flagella as well but having a compartmentalized intracytoplasmic membrane with cell size of (1.0-1.5 x 1.0-2.5)  $\mu\text{m}$ . Moreover, *Nitrosovibrio* species are polar to subpolar slender curved rods measuring (0.3-0.4 x 1.1-3.0)  $\mu\text{m}$  having as well Invaginations in the intracytoplasmic membrane [18], [22].

### **2.2.3 AOB's ecophysiology**

The microbial ecology, phylogeny and morphology are precursors of the organism's biological activities within a specific environment. Therefore, bacterial clusters characterization by eco-physiological methods would indicate the presence of specific symbiotic associations between groups of bacteria that utilize nitrogen derivatives as their substrate; such as ammonia oxidizing bacteria (AOB) and nitrite oxidizing bacteria (NOB). Based on the fact that the former two bacteria differ phylogenetically, each of them will have its unique metabolic processes in terms of type and efficiency depending on the bacterial cluster and lineage.

As shown in **Figure 2-1**, AOBs can be divided into three groups, each has its unique eco-physiological parameters and preferred habitats. The first group is *Nitrosomonas* genus which is divided into six lineages. The first lineage which comprises 4 species -*Nitrosomonas europaea*, *Nitrosomonas eutropha*, *Nitrosomonas halophila*, and *Nitrosomonas mobilis*- is characterized by its moderate

salt requirement, negative urease activity, substrate affinity of (30-61)  $\mu\text{M}$ , and can be isolated from sewage disposal plants, eutrophic fresh water and brackish water as shown in **Figure 2-1**. Whereas, the second *Nitrosomonas* lineage which comprises 3 species - *Nitrosomonas communis*, *Nitrosomonas sp. I*, *Nitrosomonas sp. II* - has no salt requirement, as well no urease activity with less substrate affinity of (14-43)  $\mu\text{M}$  and is present in non-acidic soils. Furthermore, the third lineage which comprises *Nitrosomonas nitrosa* species has no salt requirement as well but with positive urease activity and moderate substrate affinity (19-46)  $\mu\text{M}$  and is commonly found in eutrophic fresh water. Moreover, the fourth *Nitrosomonas* lineage which comprises 2 species - *Nitrosomonas ureae* and *Nitrosomonas oligotropha* has no salt requirement, positive urease activity with the least substrate affinity (1.9-4.2)  $\mu\text{M}$ , and its preferred habitats are oligotrophic fresh water and natural salts. Lastly, the fifth and sixth lineage comprising *Nitrosomonas marina*, *Nitrosomonas sp. III*, and *Nitrosomonas aestuarii* and *Nitrosomonas cryotolerans*, respectively both are obligate halophilic, have positive urease activity and usually found in marine environment, and have highest substrate affinity (50-52) and (42-59)  $\mu\text{M}$  for the fifth and sixth lineage, respectively. On the other hand, the second group of AOBs comprises *Nitrosolobus multiformis*, *Nitrosovibrio tenuis* and *Nitrosospira sp. I* having all similar eco-physiological parameters of no salt requirement, positive or negative urease activity and are found in soils, rocks and fresh water. Whereas, the

last group comprises *Nitrosococcus oceani* and *Nitrosococcus halophilus* which are obligate halophilic and found in marine environment with positive urease activity for the former and negative urease activity for the latter [18].

Moreover, AOB characteristics and predominant species vary in engineering systems according to the reactor type (i.e. Continuous stirred tank reactors (CSTR), Sequential batch reactors (SBR), Single reactor for high activity ammonia removal over nitrite (SHARON), Moving bed biofilm reactors (MBBR),etc.), influent characteristics (i.e. freshwater, raw wastewater, etc.) and operational conditions (i.e. temperature, pH, DO, etc.) which strongly affect the microbial ecology [23]. It may be speculated that there is two types of AOB according to the affinity of ammonia: (i) k-strategists which has lower growth rate and higher ammonia affinity, thus dominate in ammonia limited conditions and (ii) r-strategists which has higher growth rate and lower ammonia affinity and by consequence dominate in abundant ammonia conditions [24].

In terms of different influent characteristics, Burrell et al. (2001) reported during studies on freshwater based on FISH analysis that *Nitrosomonas marina* outcompeted *Nitrosomonas europaea* in low ammonia concentrations while in high concentrations *Nitrosomonas europaea* was dominant [25]. Therefore, AOB communities were investigated in 12 wastewater treatment plants (8 SBRs and 4 activated sludge) using DGGE and it was reported that in 11 wastewater treatment

plants (WWTPs) where the influent was characterized with high ammonia concentrations the dominant species were *Nitrosomonas europaea* and *Nitrosomonas eutropha* whereas in WWTP with low ammonia concentrations *Nitrosomonas ureae*, *Nitrosomonas oligotropha* and *Nitrosomonas marina* were dominant [26]. Additionally, in salty wastewaters *Nitrosococcus mobilis* (falling within the *Nitrosomonas* species) was reported to be dominant [27].

Additionally, in terms of reactor configuration it can be divided to two main systems: suspended growth reactors and attached growth reactors. In the case of suspended growth systems, in a partial nitrification SBR treating landfill leachate with extremely high nitrogen concentration *Nitrosomonas europaea* and *Nitrosomonas eutropha* were detected using PCR amplification and DGGE fingerprinting [4]. Moreover, it was found that the addition of landfill leachates into municipal wastewater in a partial nitrification SBR had an effect on the morphologic structure of AOB communities decreasing their diameter and increasing the microcolonies distribution in the flocks [3]. On the other hand in a partial nitrification CSTR treating synthetic wastewater with high ammonia concentrations and devoid of any organic carbon, qPCR analysis revealed that the dominant AOB cluster was *Nitrosomonas europaea* suggesting it could be part of r-strategists [28]. Further, analysis of a 16S rRNA gene revealed that in the single reactor system for

high activity ammonia removal over nitrite (SHARON) *Nitrosomonas eutropha* was dominant clone with 69% of the clones [29].

In the case of attached growth systems, the diversity of AOB communities was compared in a biological aerated filter (BAF) and a trickling filter treating identical wastewater using PCR analysis targeting 16S rRNA gene sequence combined with DGGE. A difference in the community structure was noted between the two systems with a higher diversity of AOB in the trickling filter than in the BAF although *Nitrosococcus mobilis* dominated all the samples analyzed in both reactors [30].

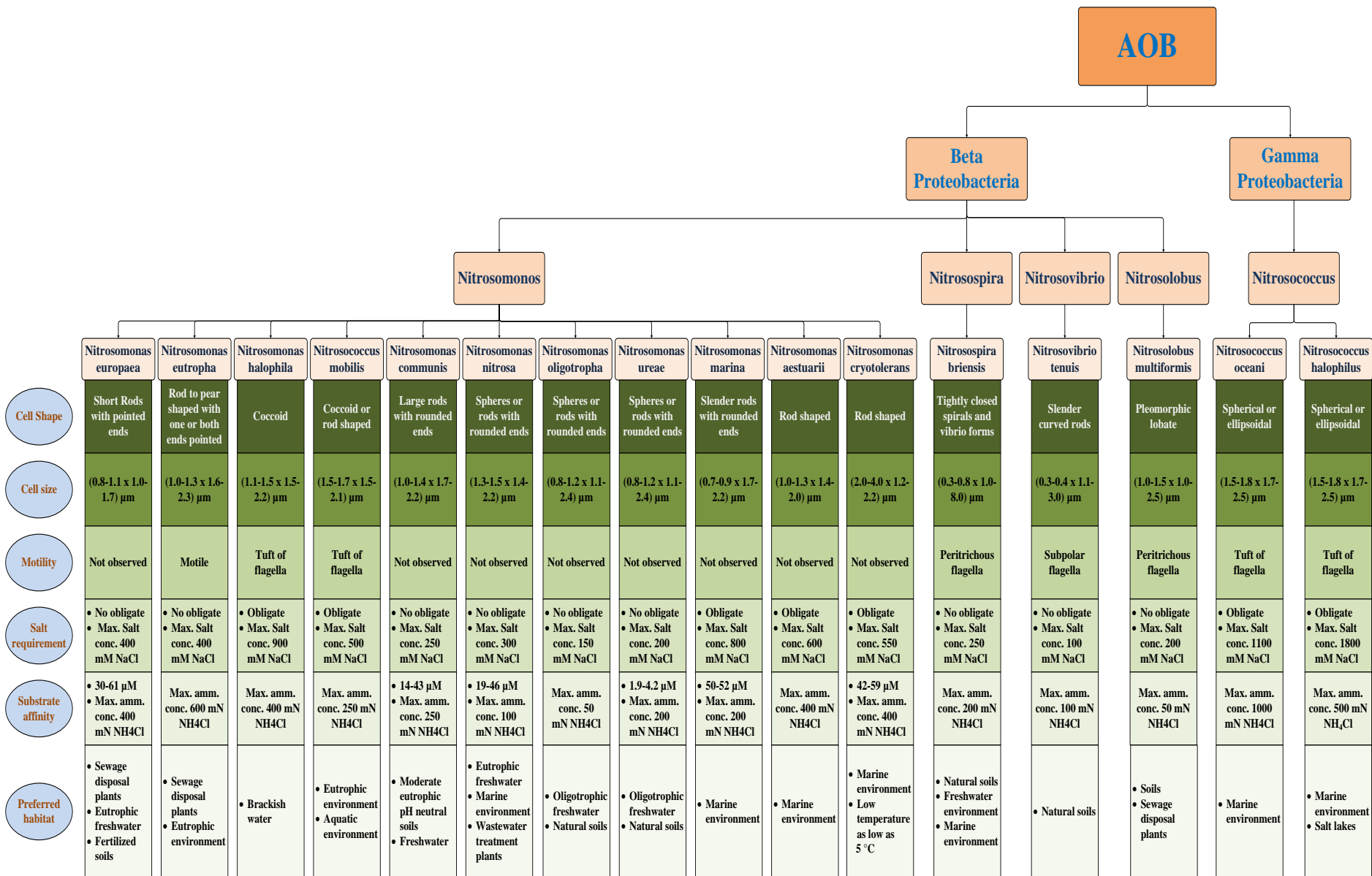
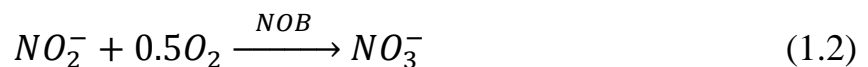
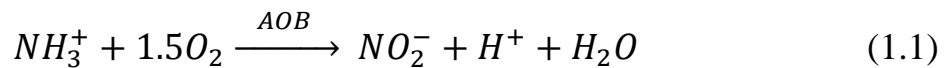

**Figure 2-1: Morphological and Eco-physiological Characteristics of reported Ammonia Oxidizing Bacteria's species**

## 2.2.4 AOB's Physiology

Nitrogen is usually present in wastewater in 3 forms: (i) organic nitrogen compounds, (ii) ammonium ( $\text{NH}_4^+$ ), and (iii) trace amounts of nitrite ( $\text{NO}_2^-$ ) and nitrate ( $\text{NO}_3^-$ ). However, the organic fractions such as proteins, amino acids, and amino sugars are degraded immediately to ammonium ( $\text{NH}_4^+$ ) either in the sewer systems or in the bioreactor [31]. In conventional BNR plants, ammonia which was suggested to be the true substrate for the oxidation process and not ammonium [32] is oxidized to nitrate via autotrophic nitrification followed by its reduction to nitrogen gas via heterotrophic denitrification.

Nitrification is a two-step aerobic biological oxidation process. The first velocity-limiting process step consists of the conversion of ammonia to nitrite carried out by ammonia oxidizing bacteria (AOB) (Eq. (1.1)). While the second step which is a rapid step consists of the conversion of nitrite to nitrate carried out by nitrite oxidizing bacteria (NOB) (Eq. (1.2)).



The first step of nitrification carried out by ammonia oxidizing bacteria is called nitritation and comprises two steps with hydroxylamine ( $\text{NH}_2\text{OH}$ ) as an intermediate product. The first step of nitritation is the oxidation of ammonia to

hydroxylamine catalyzed by the membrane bound ammonia monooxygenase (AMO). This step requires a molecular oxygen and a pair of electrons (Eq. (1.3)). In the second step, hydroxylamine is further oxidized to nitrite catalyzed by the hydroxylamine oxidoreductase (HAO) using oxygen from water and an additional molecular oxygen as a terminal electron acceptor (Eq. (1.4)). This step generates two pairs of electrons, one pair of which is compensated for the support of the first step of ammonia oxidation, whereas the other pair is passed to the terminal oxidase via an electron transport chain, generating a proton motive force [33].

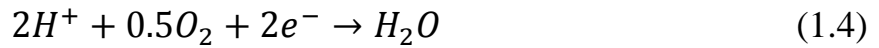
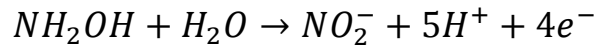

The previous reaction (Eq. (1.1)) serves as energy-yielding reaction for AOB which utilize ammonia as their sole source of energy. Besides being AOB energy source, part of the ammonia is used for their cell growth as nitrogen source while carbon dioxide serves as their chief carbon source. If the empirical formulation  $C_5H_7NO_2$  for the gross composition of the biomass is considered acceptable for AOB, the growth can be expressed by the following reaction (Eq. (1.5)):

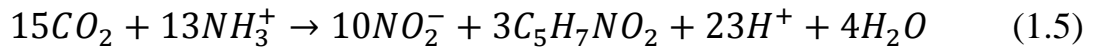

The energy released from the ammonia oxidation (Eq. (1.1)) is utilized in the synthesis reaction (Eq. (1.5)). Moreover, the free acid ( $H^+$ ) produced from the oxidation and synthesis reactions reacts to produce carbonic acid ( $H_2CO_3$ ) according to the following reactions (Eq. (1.6)):

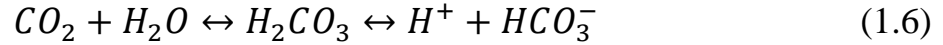

Therefore, the energy and synthesis reactions can be reformulated to Eq. 1.7 and Eq. 1.8, respectively after taking in consideration the effect of the previous reaction.

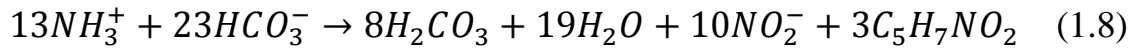
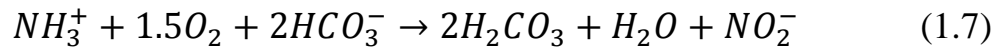

It can be deduced from the past 2 reactions that the nitrification process results in destruction of alkalinity through the production of hydrogen ions.

### **2.2.5 AOB's Enzymology**

As discussed in the previous section, the ammonia oxidation to nitrite is a two steps process, ammonia oxidation to hydroxylamine followed by its further oxidation to nitrite. The second step -hydroxylamine oxidation to nitrite- is carried out by a periplasm-associated enzyme hydroxylamine oxidoreductase (HAO) generating 4 electrons that serves as the sole source of reducing equivalents for the first step of ammonia oxidation as well as cell synthesis. These electrons are

transported from HAO through cytochrome  $c_{554}$  - an electron acceptor to HAO - to membrane cytochrome  $c_{552}$  then distributed by the ubiquinone pool [34]. Two of the 4 generated electrons are returned to a membrane-bound multisubunit enzyme ammonia monooxygenase (AMO) to perform ammonia conversion to hydroxylamine [35]. Furthermore, 1.65 electrons of the remaining pair of electrons are passed through cytochrome  $c_{552}$  to cytochrome  $aa_3$  to the terminal electron acceptor  $O_2$  and reduced to form  $H_2O$  while the remaining 0.35 electrons are used for the reduction of  $NAD^+$  to NADH through 'reverse electron flow' performed by the embedded electron carrier NADH dehydrogenase as illustrated in **Figure 2-2**. It was also suggested that in case of low dissolved oxygen concentrations a portion of the 1.65 electrons passed to the terminal oxidase might pass to nitrite reductase (NiR) and nitric oxide reductase (NoR) enzymes producing nitric oxide (NO), nitrous oxide ( $N_2O$ ) and trace amounts of nitrogen gas ( $N_2$ ) [36].

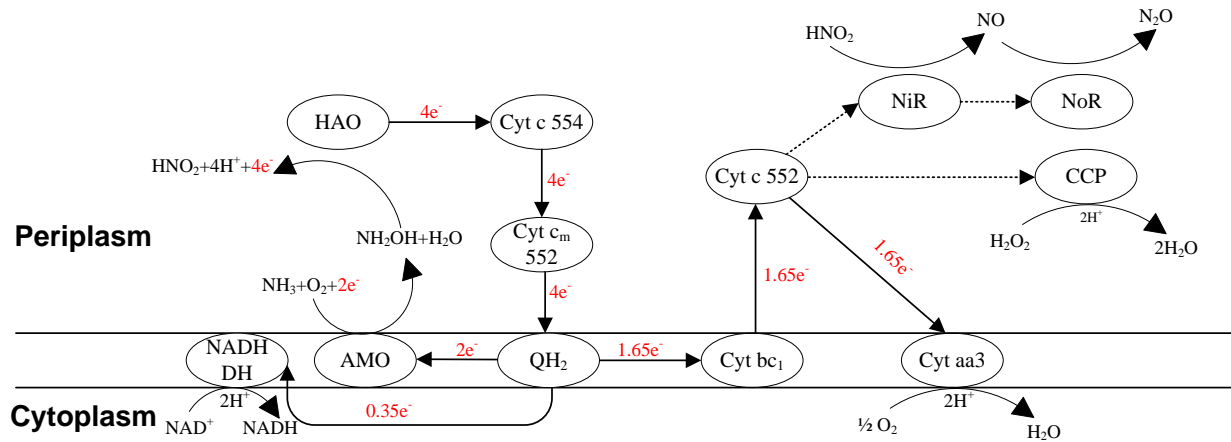

**Figure 2-2: Electron transport pathways in AOB**

*HAO*, hydroxylamine oxidoreductase; *Cyt c 554*, cytochrome *c554*; *Cyt cm 552*, membrane cytochrome *c552*; *QH2*, ubiquinol; *AMO*, ammonia monooxygenase; *NADH DH*, NADH dehydrogenase; *Cyt bc1*, Complex 3; *Cyt c 552*, cytochrome *c552*; *Cyt aa3*, cytochrome *c* oxidase; *NiR*, nitrite reductase; *NoR*, nitric oxide reductase; *CCP*, cytochrome *c* peroxidase

## 2.2.6 AOB's Kinetics

The AOB and NOB kinetics have been thoroughly studied due to their crucial importance in controlling and optimizing nitrogen removal processes. However, an evident variation has been observed in the reported kinetics values as shown in **Table 2-1** and **Table 2-2**. This wide range in the values of kinetics parameters is due to the different conditions that vary from a study to another such as: wastewater characteristics (low or high strength), operational conditions (temperature, pH, DO), reactor configuration (suspended or attached growth), identification technique (experimental or model based) [37].

As a matter of fact, temperature is a critical parameter that governs nitrification kinetics as at higher temperature AOB was reported to outcompete NOB whereas at lower temperature NOB are able to oxidize nitrite much faster [38]. It was reported in several studies that temperature significantly affects the maximum specific growth rate for both AOB and NOB with higher values for AOB at higher temperature which is the condition the SHARON process relied on to achieve partial nitrification [39]–[41]. Another parameter that might alter the kinetics value is the DO concentrations. Canziani et al. (2006) studied the effect of oxygen concentration on nitrifiers kinetics in a MBR treating landfill leachate. It was reported that low DO concentrations increases the difference between the maximum specific growth rate ( $\mu_{\max}$ ) of AOB and NOB. At high DO ( $> 1.5$  mg/L),  $\mu_{\max}$  of AOB and NOB were 0.625 and 0.555  $d^{-1}$  respectively, decreasing the DO to the range of 0.0-0.5 mg/L resulted in a decrease in both AOB and NOB growth rates but at a higher rate for that of NOB which lost around 75% of its  $\mu_{\max}$  against only 28% for that of AOB. Moreover after slightly increasing the DO to the range of 0.5-1.5 mg/L, AOB completely recovered its maximum specific growth rate whereas NOB  $\mu_{\max}$  was still 30% lower than the value calculated at high DO. The previous results implying the inhibition of NOB at low DO concentrations may be attributed to the higher affinity for oxygen of AOB than NOB [38].

**Table 2-1: Summary of reported AOB kinetic parameters**

Symbol	Name	Unit	Reactor type	Temperature	Range	References
<b>Suspended growth</b>						
$\mu_{\max}$	Maximum growth rate	$d^{-1}$	CSTR	Ambient	<b>0.24-1.21</b>	[28], [42]–[48]
				High	<b>0.9-2.1</b>	[49]–[54]
			SBR	Ambient	<b>0.46-1.06</b>	[55]–[57]
				High	<b>0.94-1.96</b>	[49], [58]–[60]
$b_{\text{aerobic}}$	Aerobic decay rate	$d^{-1}$	CSTR	Ambient	<b>0.048-0.32</b>	[28], [45]–[48]
				High	<b>0.17-0.23</b>	[51], [54]
			SBR	Ambient	<b>0.071</b>	[56]
				High	<b>0.245-0.26</b>	[58], [60]
$K_{\text{NH}_4}$	Substrate ( $\text{NH}_4$ ) half saturation constant	mg N/L	CSTR	Ambient	<b>0.14-0.7</b>	[45], [48], [61]
				High	<b>0.44-0.75</b>	[50], [51], [53], [54]
			SBR	Ambient	<b>1.0-1.35</b>	[55]–[57]
				High	<b>0.5</b>	[59]
$K_o$	Oxygen half saturation constant	mg $\text{O}_2$ /L	CSTR	Ambient	<b>0.3-0.79</b>	[45], [48], [61]–[63]
				High	<b>0.25-0.94</b>	[49], [51], [53], [54]
			SBR	Ambient	<b>0.307-0.5</b>	[55]–[57]
				High	<b>0.34-0.36</b>	[49], [58]
$Y$	Yield	mg COD/ mg N	CSTR	Ambient	<b>0.11-0.18</b>	[28], [42], [45], [48]
				High	<b>0.15-0.2</b>	[49], [51]
			SBR	Ambient	<b>0.15-0.39</b>	[55], [56]
				High	<b>0.18-0.39</b>	[49], [60], [64]
<b>Attached growth</b>						
$\mu_{\max}$	Maximum growth rate	$d^{-1}$	MBR – FBBR- BAS	Ambient	<b>0.18-1.08</b>	[43], [44], [47], [65]
				High	<b>0.33-3.40</b>	[66]–[68]
$b$	Aerobic decay rate	$d^{-1}$	MBR	Ambient	<b>0.08</b>	[47]
				High	<b>0.017-0.17</b>	[68]
$K_{\text{NH}_4}$	Substrate ( $\text{NH}_4$ ) half saturation constant	mg N/L	MBR FBBR	Ambient	<b>0.13</b>	[61]
				High	<b>0.72</b>	[69]
$K_{\text{O}_2}$	Oxygen half saturation constant	mg $\text{O}_2$ /L	MBR- FBBR MBR	Ambient	<b>0.176-0.57</b>	[61], [62], [65]
				High	<b>0.07-0.68</b>	[67], [68]
$Y$	Yield	mg COD/ mg N	FBBR MBR	Ambient	<b>0.17</b>	[65]
				High	<b>0.09-0.41</b>	[68]

**Table 2-2: Summary of reported NOB kinetic parameters**

Symbol	Name	Unit	Reactor type	Temperature	Range	Reference
<b>Suspended growth</b>						
$\mu_{\max}$	Maximum growth rate	d <sup>-1</sup>	CSTR	Ambient	<b>0.16-2.6</b>	[28], [42]–[48]
				High	<b>0.56-1.05</b>	[50]–[52], [54]
			SBR	Ambient	<b>0.48-0.56</b>	[56], [70]
				High	<b>0.674-2.51</b>	[58], [59]
$b_{\text{aerobic}}$	Aerobic decay rate	d <sup>-1</sup>	CSTR	Ambient	<b>0.045-1.7</b>	[28], [45]–[48]
				High	<b>0.04-0.17</b>	[51], [54]
			SBR	Ambient	<b>0.069-0.08</b>	[56], [70]
				High	<b>0.245</b>	[58]
$K_{\text{NO}_2}$	Substrate (NO <sub>2</sub> ) half saturation constant	mg N/L	CSTR	Ambient	<b>0.28-1.6</b>	[43], [61]
				High	<b>0.02-0.05</b>	[51], [54]
			SBR	Ambient	<b>1.49-3</b>	[56], [70]
				High	<b>1.62</b>	[59]
$K_o$	Oxygen half saturation constant	mg O <sub>2</sub> /L	CSTR	Ambient	<b>0.43-1.75</b>	[42], [45], [48], [61]–[63]
				High	<b>0.5-0.73</b>	[51], [54]
			SBR	Ambient	<b>0.357-1.0</b>	[56], [57]
				High	<b>0.54</b>	[58]
$Y$	Yield	mg COD /mg N	CSTR	Ambient	<b>0.04-0.2</b>	[28], [42], [45], [48]
				High	<b>0.09</b>	[51]
			SBR	Ambient	<b>0.041</b>	[56]
				High	<b>0.1</b>	[58]
<b>Attached growth</b>						
$\mu_{\max}$	Maximum growth rate	d <sup>-1</sup>	MBR –	Ambient	<b>0.162-1.53</b>	[43], [44], [47], [65], [71]
			FBBR-BAS	High	<b>0.129-3.54</b>	[66]–[68]
$b$	Aerobic decay rate	d <sup>-1</sup>	MBR	Ambient	<b>0.11</b>	[47]
				High	<b>0.012-0.18</b>	[68]
$K_{\text{NH}_4}$	Substrate (NH <sub>4</sub> ) half saturation constant	mg N/L	MBR -	Ambient	<b>0.17-5.04</b>	[43], [61], [65], [71], [72]
			BAS FBBR	High	<b>0.46</b>	[69]
$K_{\text{O}_2}$	Oxygen half saturation constant	mg O <sub>2</sub> /L	MBR-	Ambient	<b>0.176-0.57</b>	[61], [62], [65], [71]
			FBBR	High	<b>1.78-1.98</b>	[67], [69]
$Y$	Yield	mg COD /mg N	FBBR	Ambient	<b>0.06</b>	[65]
			MBR	High	<b>0.02-0.2</b>	[68]

## 2.3 Parameters affecting AOB

Effective partial nitrification could be achieved by accumulating AOB and inhibiting NOB. Successful AOB accumulation depends upon the knowledge of the parameters affecting their growth. These parameters may include appropriate regulation of the reactor's dissolved oxygen concentration (DO), temperature, pH, hydraulic retention time (HRT), solids retention time (SRT), alkalinity as well as the presence of free ammonia.

### 2.3.1 Dissolved Oxygen Concentration

Controlling the dissolved oxygen concentration in the reactor is a possible way for enhancing nitrite accumulation and by consequence accumulating AOB. It is based on the differences between the Monod saturation constant of oxygen for AOB and NOB that are known to be 0.3 and 1.1 mg/L, respectively [38]. Thus, low DO concentration might be more restrictive for the growth of NOB than AOB due to the higher affinity for oxygen of AOB as shown in **Figure 2-3**. This was clearly illustrated in the report of Hanaki et al. (1990) where low DO concentration (0.5 mg/L) produced no effect on ammonia oxidation while nitrite oxidation was strongly inhibited. Moreover, low levels of DO elevated the growth yield of AOB by double while the growth rate of NOB was unchanged [73]. However, limited DO conditions might cause sludge filamentous bulking problems and result in lower nitrification

rate [74]. On the other hand, Stenstorm and Poduska (1980) reported that there is no clear DO concentration for optimum nitrification. According to this study, one possible reason for the wide variation reported for DO concentration is the effect of the oxygen diffusion with the flocs [75]. This might explain the variation in the critical DO concentration values recorded in the literatures for controlling partial nitrification. Suspended growth and attached growth reactor systems have been conducted widely in different DO concentrations to obtain higher nitrite accumulation.

In the case of suspended growth systems, a DO concentration of 0.4-0.5 mg/L in an activated sludge reactor resulted in a nitrite accumulation rate of 96% and an AOB population of  $5.33 \times 10^8$  cell/ml. Moreover, complete nitrification was obtained at a DO concentration of 1.5-2.5 mg/L with almost unobvious nitrite accumulation rate while at a very low DO condition (0.2 mg/L) nitrite build up did not occur and nitrite accumulation rate was about 1.7% on average [76]. Wei et al. (2014) reported that high DO concentration could damage nitrite accumulation directly. According to their tests, in a sequencing batch reactor (SBR) the initial nitrite accumulation rate was decreased from 95.43% to 3.09% under a DO concentration of 2.0-4.0 mg/L while decreasing the DO concentration to 0.8 mg/L resulted in the nitrite accumulation being 93.7% [10]. Stenstorm and Poduska (1980) suggested that at higher SRT, nitrification can be achieved at DO concentrations at the level of 0.5-

1.0 mg/L and at lower SRT higher concentrations may be needed [75]. This was illustrated in the test performed in a CSTR operated at a SRT of 3 days where the DO concentration needed to maintain partial nitrification was  $1.54 \pm 0.87$  mg O<sub>2</sub>/L [28].

In the case of biofilm systems the conversion rate is usually limited by the oxygen transfer from liquid to biofilm [77]. Hence, in a biofilm airlift suspension reactor a dissolved oxygen concentration of around 1.5 mg/L was required to achieve an effluent with a high nitrite concentration while maintaining a good ammonia conversion. Whereas at dissolved oxygen concentrations below 1 mg/L ammonia oxidation decreased and resulted in lower nitrite concentrations in the effluent. Moreover, ammonia was completely converted to nitrate when the dissolved oxygen in the reactor was over 2.5 mg/L [78]. Additionally, in a static sequencing batch worm reactor a DO concentration of 1.5 mg/L was reported to inhibit NOB [79]. It was suggested that the high ammonia oxidation rate compared to the nitrite oxidation rate at lower oxygen concentrations may be due to a localization of the NOB in the inner biofilm regions as well as the lower oxygen half-saturation constant for AOB [80].

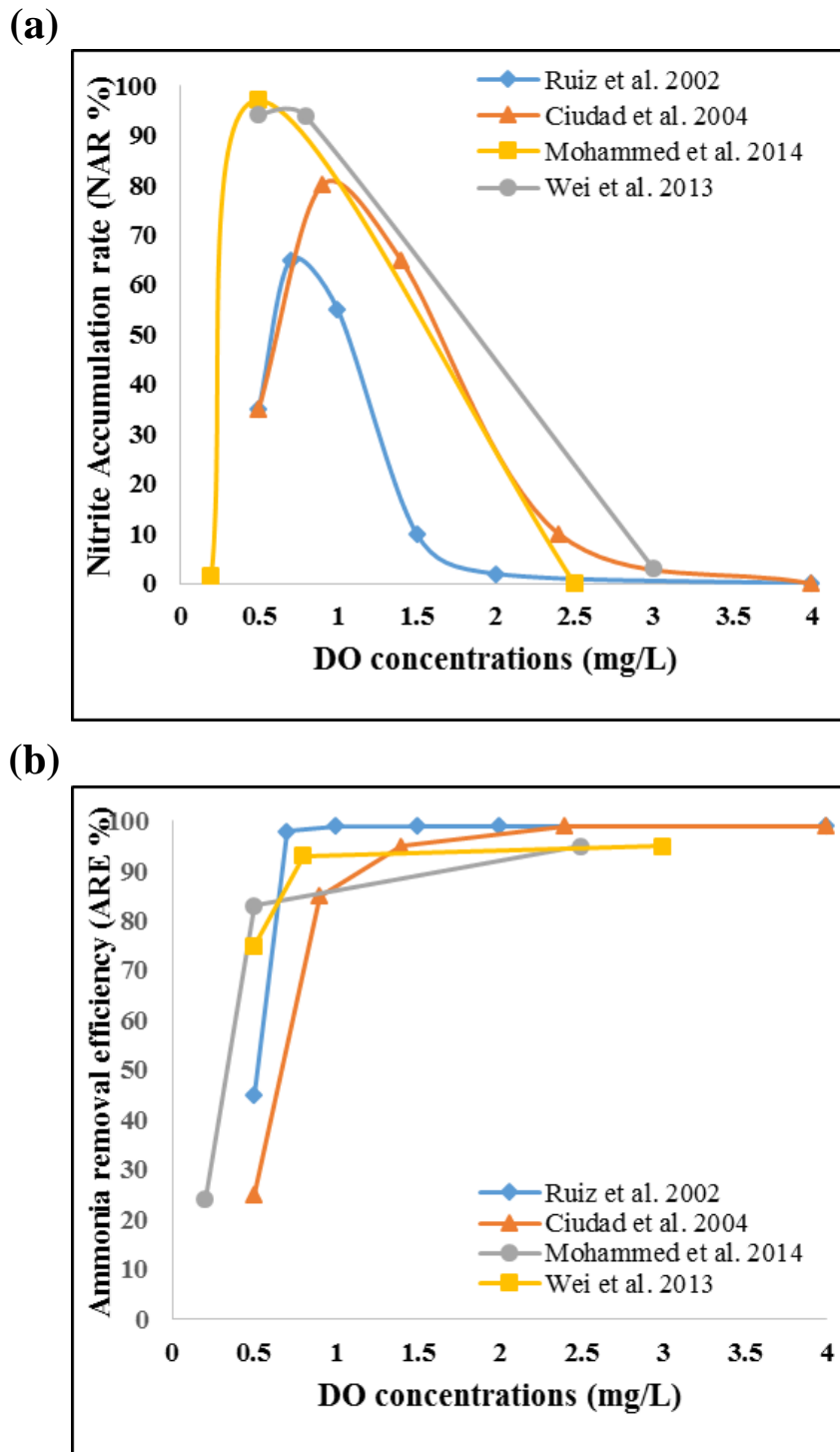

**Figure 2-3: Performance of Partial nitrification suspended systems during different DO concentrations in terms of: (a) Nitrite accumulation rate (NAR); (b) Ammonia removal efficiency (ARE)**

### 2.3.2 Temperature

Temperature has a clear effect on the ammonia oxidation in partial nitrification systems. Nitrification usually proceeds better in warmer seasons. The effect of temperature on nitrogen removal was investigated in batch biofilm reactors. The ammonia removal efficiency was higher as the reactors temperatures increased to reach more than 80% at 25 °C while it went below 30% at 15 °C and lower [81]. Moreover, it was noted that nitrite accumulated in an activated sludge plant especially over the summer period [82]. It has been suggested that NOB has slower growth rates than AOB when temperature goes up from 24 °C, while low temperatures lead to NOB domination over AOB in partial nitrification [83]. In the same manner, Nitrobacter (usually the NOB dominant species in nitrification) was reported to be active at a range of temperature between 10 °C and 20 °C while nitrite build-up remained low despite the FA concentration that normally inhibits the Nitrobacter activity which shows that the temperature effect of the Nitrobacter activation prevailed over its inhibition by FA. On the other hand, raising temperature to a range between 20 °C and 25 °C resulted in an activation of the ammonia oxidation activity together with a slowing of the nitrite oxidation activity [84]. Moreover, in an inverse turbulent bed reactor raising the temperature from 30 °C to 35 °C resulted in a decrease in nitrate concentration in the outlet of the reactor combined with a simultaneous increase in the nitrite concentration [85].

However, partial nitrification could be achieved at low temperatures if the conditions for AOB to outcompete NOB were created [86].

Furthermore, temperature affects the chemical equilibriums of free ammonia (FA) and free nitrous acid (FNA) which influences the performance of partial nitrification. In a sequencing batch reactor, FA concentrations increased from  $20.76 \pm 4.23$  mg N-NH<sub>3</sub>/L on average at a temperature of 25 °C to  $122.92 \pm 27.23$  mg N-NH<sub>3</sub>/L on average at a temperature of 35 °C, whereas FNA levels showed the opposite behavior decreasing from  $0.47 \pm 0.09$  mg N-HNO<sub>2</sub>/L to  $0.12 \pm 0.02$  mg N-HNO<sub>2</sub>/L [4].

In practice, partial nitrification reactors are commonly operated at a temperature of range between 30-35 °C. However, in practical operation there is no much difference between 25 °C and 35 °C in terms of growth of AOB and NOB and by consequence 25° C is considered enough for the purpose of NOB control [83].

### **2.3.3 pH, free ammonia (FA) and free nitrous acid (FNA)**

The value of pH influences the equilibrium of free ammonia (FA) and free nitrous acid which have an inhibitory effect on both AOB and NOB, thus regulating pH is commonly used to achieve partial nitrification. The nitrite oxidizers appears to be more sensitive to free ammonia as a value of 0.1-1.0 mg FA/L was reported to inhibit NOB while 10-150 mg FA/L is necessary for the AOB inhibition [87]. In that

manner, almost similar ranges were reported in other studies where NOB was inhibited at a range of 0.1-4.0 mg FA/L in batch reactors [88] and 1-5 mg FA/L in Anaerobic-Aerobic Treatment of High-Strength Ammonium Wastewater whereas AOB was inhibited at FA concentrations higher than 7 mg/L and stopped at 20 mg/L [89]. However, free ammonia was reported to only inhibit NOB not to kill them and after a long period of cultivation nitrite oxidizers can be adapted to high free ammonia concentration and recover activity [90]. The relationship between free ammonia concentration and pH is as follows [87]:

$$FA \left( \frac{mg}{L} \right) = \frac{17}{14} X \frac{NH_3-N X 10^{pH}}{10^{pH} + \exp\left(\frac{6344}{273+T}\right)} \quad (10)$$

Along with free ammonia concentration, nitrite oxidizers are more sensitive to free nitrous acid than ammonia oxidizers. FNA concentration of 0.42-1.72 mg-N/L resulted in a 50% reduction in AOB activity while lower concentration of 0.011-0.07 mg-N/L started to inhibit NOB and 0.026-0.22 mg-N/L could completely inhibit NOB [91]. Moreover in an activated sludge, FNA acted as an uncoupler by donating a proton inside the cell which directly interferes with the transmembrane pH gradient required for ATP synthesis causing the inhibition [92]. The relationship between free nitrous acid and pH is as follows:

$$FNA \left( \frac{mg}{L} \right) = \frac{46}{14} X \frac{NO_2-N}{10^{pH} X \exp\left(-\frac{2300}{273+T}\right)} \quad (11)$$

Therefore, most of the literature suggests that pH in the range of 7.5-8.5 is most suited to inhibit NOB. It has been reported that the optimal pH for Nitrosomonas species ranges between 7.9 and 8.2, while for Nitrobacter species it ranges between 7.2 and 7.6 [93]. Likewise, a pH between 7.5 and 7.8 was suggested to favor partial nitrification [94]. Moreover, in a nitrifying biofilm activity nitrite accumulation started above pH 7.5 and increased to 85% at pH of 8.5 [95]. These results were similar with those of Abeling and Seyfried (1992) who reported that pH should be maintained over 7.5 to inhibit NOB and accumulate nitrite [89].

#### **2.3.4 HRT and SRT**

HRT and SRT adjustments can lead to change in microbial community in wastewater treatment plants resulting in washing out NOB populations knowing that the minimum doubling time of AOB is 7-8 h shorter than that of NOB 10-13 h [96]. Conventionally, HRT and SRT are set up to be the same time in partial nitrification reactors. However, the development of decoupled HRT and SRT partial nitrification reactors has been attempted by the biomass recycling or the attached growth systems which increases the SRT with respect to HRT.

The effect of HRT on partial nitrification reactors has been studied in several studies. In the case of suspended growth systems, in an activated sludge at HRT of 9.1 h a nitrite accumulation rate of 96 % was achieved [76]. Moreover, the effect of

HRT on partial nitrification was investigated in a SBR using precultured aerobic granules in continuous flow reactor. At HRT of 12 h and 7.2 h, both the removal efficiency of ammonia and the nitrite accumulation rate exceeded 90%. Whereas the removal efficiency of ammonia was decreased and fluctuated (20-56%) at HRT of 2.4 h [97]. On the other hand, in a sequencing batch reactor treating acrylic fiber wastewater the optimal HRT was 20 h. At this HRT, the ammonium removal rate reached 97% with a nitrite accumulation of 87% [98].

In the case of attached growth systems, on average 82% of ammonium was converted to nitrite in a MBR when HRT was controlled at 10 h [99]. Moreover, the influence of HRT on biofilms was investigated in a plastic SHARON bioreactor constructed as a submerged biofilter with PVC carriers. It was found that at HRT of 12 h 100% of the ammonia was converted to nitrite, while decreasing the HRT to 9.6 h resulted in the reduction of the quantity on ammonia converted to nitrite to 60%. Furthermore, the HRT of 12 h resulted in the formation of highly specialized biofilms mainly by *Nitrosomonas* species which are effective in the ammonia to nitrite biotransformation. In contrast, controlling the reactor at an HRT of 9.6 h facilitated the formation heterogeneous biofilms that allow a closer ammonium to nitrite ratio [100]. However, in a hybrid moving bed biofilm reactor, an HRT of 9.5 h led to the maximum population of AOB [101],

The SRT also has a crucial influence on bacterial communities in partial nitrification reactors. In suspended growth systems, based on experiences in a CSTR, controlling the reactor at a SRT of 3 days led to NOB washout [28]. However, successful partial nitrification were reported under longer sludge age in other studies. In an activated sludge process a SRT of 10 to 13 days was reported to be more appropriate for AOB accumulation with a nitrite accumulation rate of 95%. Furthermore, under shorter SRT stable partial nitrification deteriorated, whereas increasing the SRT to 16 days resulted as well in a decrease in nitrite accumulation rate from 93% to 37% [76].

## **2.4 Suspended Partial Nitrification Technologies**

### **2.4.1 Sequential Batch Reactor (SBR)**

In recent years, sequencing batch reactors (SBR) have been adopted widely as an efficient technology for wastewater treatment due to its simple configuration. These systems have been successfully used to treat both municipal and industrial wastewater. SBRs are considered as fill and draw version of the activated sludge, basically a batch reactor operating under a series of operations that constitute the SBR cycle. This cycle typically includes the following operations: fill, react, settle, decant and idle. **Figure 2-4** illustrates examples of the SBRs cycle used in partial nitrification systems. The difference between SBR and activated sludge technologies

is that the former performs biological treatment and sedimentation within the same reactor using a time control sequence while the latter uses separate reactors for treatment and sedimentation.

SBRs have shown great success in achieving nitrite accumulation at high nitrogen loading rates. This type of reactors has discontinuous feeding which allows the reactor to maintain high ammonia concentration. Thus, SBR are suitable to treat ammonia-rich organic wastewater with variable nitrogen loads such as landfill leachate and slaughterhouse wastewater. Disturbance effects resulting from receiving high ammonium loading shocks contained in leachates would be less important due to the high biomass concentration inside the reactor as well as the sequencing of the feeding phase would help to control possible FA and FNA accumulations inside the reactor and by consequence inhibiting NOB. Provided that partial nitrification in SBRs relies on NOB inhibition by FA & FNA concentrations, NOB washout will be extremely influenced by ammonia concentration and nitrogen loading rate. Moreover, AOB could also be inhibited by higher FA & FNA concentrations, thus controlling them is a key factor to maintain partial nitrification in SBRs.

Stable partial nitrification in a SBR treating landfill leachate with extremely high nitrogen concentration was achieved at both 25 °C and 35 °C [4]. The SBR cycle had a total duration of 1440 min divided into 14 sub-cycles of 100 min each,

a 20 min settling phase and a 20 min draw phase. Each sub-cycle consisted of 10 min of aerobic feeding and 90 min of aerobic reaction. DO and pH were maintained at over 2 mg O<sub>2</sub>/L and below 8.0 respectively. Both reactors were started at an specific nitrogen rate of 0.2 kg N / kg VSS. d and was progressively raised to 0.81 ± 0.11 kg N / kg VSS. d and 0.84 ± 0.24 kg N / kg VSS. d at 25 °C and 35 °C respectively by increasing the daily influent flow. At stable state, HRT was about 4.5 days and 12.0 days at 25 °C and 35 °C respectively, additionally the reactor suspended solids concentration was 1306 ± 620 mg VSS/ L. The molar alkalinity to ammonium ratio was 1.16 ± 0.06 and 1.12 ± 0.06 mol HCO<sub>3</sub>/mol NH<sub>4</sub> at 20 °C and 35 °C respectively. It was noticed that nitrate reached its maximum concentration during the first 10 days and then steadily decreased till the end of the experiments while nitrite started accumulating from the beginning of the experiments reaching stable concentration values of around 3500 mg N/L from day 22<sup>nd</sup> and 18<sup>th</sup> at 25 °C and 35 °C respectively. Effluent characteristics were similar for both experiments NH<sub>4</sub>, NO<sub>2</sub>, NO<sub>3</sub> were 2725.9 ± 153.2 mg N/L, 3719.2 ± 174.5 mg N/L, 41.9 ± 25.0 mg N/L and 2629.9 ± 123.4 mg N/L, 3245.5 ± 115.7 mg N/L, 25.8 ± 3.0 mg N/L at 25 °C and 35 °C respectively. It is remarkable that the nitrate concentration was lower than 1% of the total influent nitrogen for both experiments. It was suggested that FA and FNA concentration were the main factors for NOB inhibition given the extremely high ammonium content of the landfill leachate.

Moreover, nitrogen removal via nitrite of a mixture of real municipal wastewater (RWW) and an increasing quantity of real landfill leachates (RLL) in a sequencing batch reactor was investigated [3]. SBR was inoculated with nitrifying activated sludge and was fed with RWW during a 9 weeks start-up period then with a mixture of RWW and increasing quantities (1%, 2%, 5% and 10% of volume) of RLL over the following 17 weeks. The SBR cycle had a total duration of 12 h for 1 and 2 % addition of landfill leachate and 24 h for 5 and 10 %. Each cycle consisted of six phases: anaerobic filling, aerobic reaction, anoxic reaction, aerobic reaction, settling and decantation. Temperature, DO in the aerobic phase and SRT were controlled at  $20 \pm 1$  °C,  $1.0 \pm 0.5$  mg O<sub>2</sub>/L and 70-92 days respectively. In the stable portion of stable period, high ammonia removal efficiency (up to 96%) was achieved with nitrate domination in the effluent (up to 100% of the TN). During the co-treatment of RWW with the addition of RLL, the removal efficiency of ammonia was higher with values of 99% for RM1 and RM2, 91% for RM5 and 72% for RM10 with an average amount of nitrite of 62, 66, 61 and 22% for RM1, RM2, RM5 and RM10 respectively. Whereas, nitrate concentration in the effluent decreased with the addition of landfill leachates to reach an average of 31, 9, 8 and 4% for RM1, RM2, RM5 and RM10 respectively. It was suggested that the decrease of the nitrate concentration was due to the inhibition of NOB resulting from the increase in FA concentration with continuous increase of N-NH<sub>4</sub> (pH above 8) from 0.49 mg N-

NH<sub>3</sub>/L for RWW to 2.06, 3.78, 8.05 and 8.91 mg N-NH<sub>3</sub>/L for RM1, RM2, RM5 and RM10 respectively.

Furthermore, SBR can be used as a first step in the anammox process where anaerobic ammonia oxidizing bacteria oxidize ammonium to nitrogen gas using nitrite as the electron acceptor. One of the key features of an anammox reactor is the availability of suitable influent composed of 1:1.32 ammonium: nitrite molar ratio. Thus, more than half of the ammonium in the wastewater influent must previously be partially oxidized to nitrite, avoiding further oxidation of nitrite to nitrate which can be achieved in a partial nitrification SBR. This was illustrated by the experiments performed in a SBR treating urban landfill leachates to attain a suitable influent for an anammox reactor [102]. Raw leachate was collected from a landfill with NH<sub>4</sub>, COD and BOD concentrations on average of  $1623 \pm 424$  mg N-NH<sub>4</sub>/L,  $4512 \pm 649$  mg/L and  $558 \pm 257$  mg/L respectively. The SBR cycle had a duration of 8 h consisted of 360 min of aerobic feeding, 80 min of aerobic reaction, 15 min of settling and 25 min of decanting. Temperature, DO in the aerobic reaction phase, pH and HRT were controlled at  $36 \pm 1$  °C, 2 mg/L, 6.8-7.1 and 1.5 days. SRT was not controlled but calculated considering reactor MLSS and effluent suspended solids concentration and found to be 5 days on average. The SBR was inoculated with nitrifying sludge and was fed with a mixture of synthetic wastewater and urban landfill leachate with a leachate proportion in the feed increasing until reaching a

100% raw leachate on day 167. The molar ammonium to alkalinity ratio was always adjusted to 1:1 with sodium bicarbonate additions. Nitrite percentages were between 40 to 60% during the majority of the experiment, obtaining a composition close to a molar ammonium to nitrite ratio of 1:1. Despite this performance, a lower percentage of ammonium oxidation was observed each time the ammonium loading rate was increased. Nevertheless, the system recovered its performance after a period of stable influent ammonia concentration. It was suggested that this effect could be due to the possible slow response of AOB to the increasing loading rate. The stable phase was reached after 130 days of operation when the reactor was operated with 75% of raw leachate and an influent ammonium concentration of 1440 mg N/L. Under such conditions,  $\text{NH}_4$ ,  $\text{NO}_2$  and  $\text{NO}_3$  concentrations in the effluent were 725, 672 and 0.4 mg N/L respectively. Additionally, the FA and FNA concentrations were 5.58 and 0.18 mg N/L respectively. Thus, the low formation of nitrate could be explained by the FA concentration which was enough to inhibit NOB without inhibiting AOB. On the other hand, the consumption of alkalinity was very close to the ammonium oxidation by the combined effect of biological ammonium oxidation (autotrophic growth and pH regulation) and the stripping effect caused by aeration.

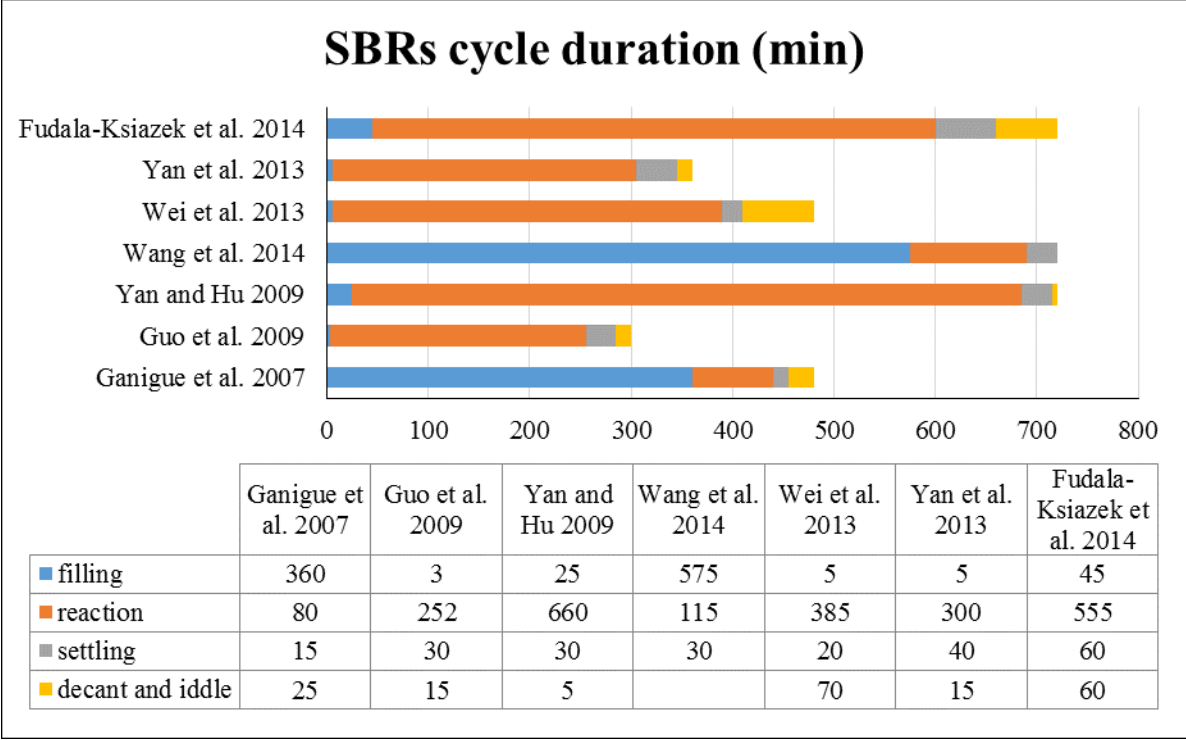

**Figure 2-4: SBR cycle duration for different partial nitrification studies**

### 2.4.2 Continuous Stirred Tank Reactor (CSTR)

Another type of reactors where partial nitrification can be performed is continuous stirred tank reactor (CSTR). This type of reactors run at steady state and has a continuous flow for reactants and products. The effect of ammonia loading rate on partial nitrification in a CSTR without biomass recycle operated over a wide range of HRT was investigated [7]. The bioreactor was inoculated by a nitrifying culture mainly comprising *Nitrosomonas* and *Nitrobacter* species and was fed in a continuous mode by pumping a medium of  $17.6 \pm 0.2$  mM ammonia at a low flow rate of 1 mL/h which was increased incrementally to reach a highest value of 115

mL/h. Mixing was provided by a magnetic stirrer and aeration was carried out through a porous air diffuser at a rate of 100 mL/min. pH was adjusted to 7.5-8.5 using sodium bicarbonate solution. The CSTR was operated at room temperature (25 °C) for 243 days. The reactor was operated under a number of applied flow rates representing low, medium and high ammonia loading rates. It was noted that at low ammonia loading rates (up to 1.0 mM/h) ammonia was almost totally oxidized with a nitrate domination (95-99% of the effluent). The average DO concentration measured was  $4.8 \pm 0.1$  mg O<sub>2</sub>/L. Increasing ammonia loading rates to the range of 1.0-3.1 mM/h resulted in an increase in nitrite concentrations and a decrease in nitrate concentration. Furthermore, increasing loading rate from 3.1 to 5.4 mM/h enhanced the production rate of nitrite to a maximum value of 2.5 mM/h ( $48.8 \pm 8.9\%$  of the effluent) and a decrease in ammonia removal rate ( $44.7 \pm 6.1\%$  ammonia in the effluent) at a corresponding HRT of 3.7h. The average DO concentration measured was  $4.8 \pm 0.2$  mg O<sub>2</sub>/L. While, increasing loading rates over 5.4 mM/h led to decreasing trends of nitrite as well as a decrease in ammonia removal rate. The average DO concentration measured was  $5.2 \pm 0.1$  mg O<sub>2</sub>/L. It was suggested that the sharp decrease in ammonia removal rate following the increases in loading rate was due to cell washout that occurred in short HRTs. Results of this experiment revealed that ammonia loading rate can be used as an alternative operating variable

to control partial nitrification and may also be used to generate a suitable influent for the Anammox process.

Moreover, a stable accumulation of 50% ammonia and nitrite to feed an anammox reactor was achieved in a CSTR followed by a settling tank operated at room temperature by pH controlled partial nitrification [103]. Regulating the ammonium to inorganic carbon ratio ( $\text{NH}_4/\text{IC}$ ) was selected as the strategy to control pH and the inhibitory effects of NA and FNA, thus inhibiting NOB activity and achieving partial nitrification. The feeding media consisted of pig slurry pretreated in an aerobic granular plant with  $\text{NH}_4$  and COD concentration of  $399 \pm 25$  mg  $\text{NH}_4\text{-N/L}$  and  $103 \pm 43$  mg  $\text{COD/L}$  respectively. Aeration was carried out through air spargers. HRT, temperature and DO were controlled at 3 days, 22-25 °C and over 2.0 mg  $\text{O}_2/\text{L}$  respectively. The CSTR was inoculated with an amount of 0.45 g  $\text{VSS/L}$  of nitrifying activated sludge occupying 25% of the liquid volume. The applied ammonia nitrogen loading rate (NLR) in the reactor was  $0.13 \pm 0.01$  kg  $\text{NH}_4\text{-N/ (m}^3\text{.d.)}$ . The reactor was operated in four different stages with different  $\text{NH}_4/\text{IC}$  ratio in the feeding ranging from 1.19 g  $\text{N/g C}$  in stage I to 0.82 g  $\text{N/g C}$  in stage IV. The  $\text{NH}_4/\text{IC}$  ratio was controlled by the addition bicarbonate without the control of pH in the influent. It was noted that in stage I 24% of the fed ammonium was oxidized to nitrite and 7% to nitrate with a nitrite to ammonium ( $\text{NO}_2/\text{NH}_4$ ) ratio of  $0.35 \pm 0.05$  in the effluent. Similar results were obtained in stage II and III where

the  $\text{NH}_4/\text{IC}$  ratio was decreased with a  $\text{NO}_2/\text{NH}_4$  ratio of  $0.49 \pm 0.07$  in the effluent. In both stages, nitrate was present in the effluent but in small amounts. Whereas, decreasing the  $\text{NH}_4/\text{IC}$  ratio to  $0.82 \text{ g N/g C}$  resulted in the oxidation of 50% of ammonium to nitrite without significant production of nitrate at a corresponding pH of 6.0. It was suggested that the nitrite accumulation that occurred in the reactor was due to the inhibitory effect of the FA and FNA. In stage I, both AOB and NOB were inhibited by FA concentration, while once the pH was decreased due to the decrease in  $\text{NH}_4/\text{IC}$  ratio in the following stages only NOB were inhibited. Whereas, FNA concentration was high enough to inhibit NOB only during stage IV.

### **2.4.3 Single reactor for high activity ammonia removal over nitrite (SHARON)**

A single reactor for high activity ammonia removal over nitrite (SHARON) process is operated in a continuous stirred tank reactor (CSTR) at a relatively high temperature ( $30\text{--}40 \text{ }^\circ\text{C}$ ) and without sludge retention which means that SRT equals HRT. Several studies have reported problems in maintaining partial nitrification in long-term operation due to NOB acclimation to the non-favoring conditions during long periods. Thus, the total washout of NOB is crucial for maintaining stable partial nitrification and to achieve this SRT is a key control parameter. Given that the specific growth rate of NOB is lower than the specific growth rate of AOB, the lower SRT the easier NOB are washout. Thus Sharon process is operated at an equal HRT

and SRT which is the lowest value of SRT. Furthermore, temperature is controlled over 30 °C to favor AOB growth and washout NOB from the system. However, in most of wastewater treatment plants room temperature is under 30 °C, thus temperatures around this value could not be maintained without a significant operational cost. Therefore, Sharon process could be costly.

An effluent ready for anammox process was obtained in a Sharon process treating real reject water [104]. Reject water was obtained from a mesophilic anaerobic digester with  $\text{NH}_4$  and COD concentrations of 800-900 mg  $\text{NH}_4\text{-N/L}$  and 1500-2000 mg COD/L respectively. The reactor was inoculated with  $250 \pm 25$  mg VSS/L of autotrophic biomass. HRT, pH and temperature were 1.2-1.4 days, 8 and 35 °C. The inorganic to ammonium ratio in the feeding was 0.98 mol  $\text{HCO}_3^-$ / mol N. The ammonium and nitrite concentrations in the effluent had an average of  $350 \pm 25$  mg  $\text{NH}_4\text{-N/L}$  and  $400 \pm 25$  mg  $\text{NO}_2\text{-N/L}$  respectively, giving a removal efficiency of 0.3 kg  $\text{NH}_4\text{-N/ (m}^3\text{.d)}$  which was transformed to nitrite. It was suggested that partial nitrification in Sharon would be the most economical treatment when combined with an anammox reactor due to the savings costs in terms of oxygen, methanol and reactors volume.

Moreover, the treatment of nitrogen rich refinery wastewater by partial nitrification was evaluated in a Sharon process and investigated the high potential toxic effect of the real wastewater on the biomass [8]. Real wastewater was taken

from the outlet of a stripping unit of a refinery plant with high alkalinity (up to 1380 mg CaCO<sub>3</sub>/L) and a dissolved organic carbon (DOC) of 240 ± 92 mg/L and toxic compounds such as sulfides, cyanides and phenols. The reactor was water-jacketed allowing the temperature to be controlled by a thermostatic water bath. Complete mixing was applied and aeration was supplied by a membrane pump and introduced through a fine bubble aerator at the bottom of reactor. The reactor was inoculated with conventional activated sludge from a municipal wastewater treatment plant. Temperature, DO concentration and pH were controlled at 35 ± 0.5 °C, 2.0 mg/L and 6.5-7.5. HRT and SRT were maintained at 1-1.25 days. The reactor was operated in 3 phases. During the first phase, it was fed with a synthetic influent containing only NH<sub>4</sub> as a substrate with a concentration increasing from 100 to 1000 mg/L with an applied volumetric nitrogen loading rate of 0.1-1.0 kg N/(m<sup>3</sup>.d.). During phase II, real wastewater was gradually added to the synthetic medium with increasing ratios and the ammonium concentration was also increased up to 2000 mg/L.

#### **2.4.4 Novel Systems**

In a novel pilot-scale six tanks activated sludge process treating real domestic wastewater a 94% nitrite accumulation was achieved through a combination of short HRT and low DO level [76]. Raw wastewater was obtained from the main manhole of a campus with NH<sub>4</sub> and COD concentrations of 40.6 mg NH<sub>4</sub>-N/L and 125.3 mg COD/L on average respectively. The system was composed of a rectangular

compartment divided by baffles to form six-compartment reactor with the last one operated as a clarifier. Mixing was provided by mechanical mixers and aeration was supplied by an air compressor through an air diffuser inside the reactor. The system was inoculated with seed sludge taken from a municipal wastewater treatment plant with SS concentration of 2820-3100 mg/L and VSS to SS ratio of 83%. Temperature was maintained at 24 °C and pH varied from 7.12 to 7.43. The system was divided to six phases alternating aerobic, anaerobic and anoxic zones. It was run for 6 successive runs. The first 2 runs were implemented to investigate nitrite accumulation throughout a combination of short HRTs of 9.1 h with normal DO of 1.5-2 mg/L concentration to compare it with runs number IV and V. Run number III was to investigate nitrite accumulation rate under a very low DO concentration of 0.2 mg/L. Run number IV and V was performed to investigate the influence of a combination of low DO of 0.4-0.5 mg/L with low HRT of 9.1 h control on partial nitrification performance. The SRT was extended from 13 to 16 days in Run number VI to investigate SRT effect on stable performance of partial nitrification. It was noted that in runs number I and II at normal DO levels, the system showed very good complete nitrification whereas the nitrite accumulation was almost unobvious during these runs. Subsequently, nitrification deteriorated in run number III at DO concentration of 0.2 mg/L and also nitrite build up did not occur. Partial nitrification via nitrite was successfully achieved during run number IV with nitrite accumulation

rate of 95%, however short HRT of 9.1 h and SRT of 10 days resulted in poor  $\text{NH}_4$  removal of 50%. Increasing HRT to 13 h and SRT to 13 days enhanced  $\text{NH}_4$  removal to over 97% with nitrite accumulation rate stabilized at over 94%. However, the extension of SRT to 16 days resulted in a decline in the nitrite accumulation rate to less than 44%.

Moreover, in an activated sludge pilot plant treating a high strength synthetic wastewater mimicking reject water with a configuration of three continuous reactors in series plus a settler partial nitrification was achieved through a combination of free ammonia inhibition and DO limitation linked to a properly selected SRT for the selective washout of NOB [105]. The synthetic influent mimicked the reject water from the dewatering process of anaerobic digested sludge with high ammonium concentration and low COD concentration of  $1150 \pm 150$  mg  $\text{NH}_4\text{-N/L}$  and 30-35 mg COD/L respectively. The system was inoculated with activated sludge of a municipal wastewater treatment plant with total biomass concentration of 2100 mg VSS/L composed of  $97 \pm 2\%$  heterotrophs,  $2 \pm 0.5\%$  AOBs and  $<1\%$  NOB. The three reactors were connected in series and worked under complete mixing conditions. A fraction of reactor 3 effluent was recycled to reactor 1 (internal recycle) as well as an external recycle from the settling tank to reactor 1 to maintain the biomass concentration in the reactors. Temperature, SRT and DO concentration were maintained at 30 °C,  $8 \pm 3$  days and 2.0 mg/L respectively. The pH was

controlled at  $8.3 \pm 0.1$  in reactor 1 and 2 to increase the fraction of free ammonia and maintained at 8.2 in reactor 3. The start-up of partial nitrification from the activated sludge with the low percentage of nitrifying bacteria was achieved in 30 days resulting in a nitrifying system with a biomass concentration of 1200 mg VSS/L and an AOB fraction of  $72 \pm 10\%$ . It was suggested that the decrease in biomass concentration from 2100 to 1200 mg VSS/L was due to the decay of heterotrophic bacteria because of the low COD concentration in the effluent. After the start-up period, the system was successfully operated for 800 days and it was noted that the inlet ammonium was fully oxidized to nitrite during the whole operation period except for some short periods when nitrite accumulation rate decreased to 70%. The nitrate accumulation during these periods was suggested to be caused by an SRT increase in the system due to the unexpected improvement in settling properties which increased the biomass concentrations in the reactors and by consequence allowed NOB growth. Other than that the AOB fraction was maintained around  $80 \pm 7\%$  while the NOB population was around  $<1 \pm 0.4\%$  during the long term operation. A high volumetric ammonium nitrogen oxidation rate of  $2.0 \pm 0.4$  g N/L/d was achieved in this system.

## 2.5 Attached Partial Nitrification Technologies

In conventional treatment systems bacteria are grown in flocs which refer to an assemblage of individual cells or micro colonies that take place in a reactor under particular conditions or after the addition of an agent to the medium [16]. These flocs are usually prone to be washed-out easily which could be a restraint for slow-growing bacteria like AOB. An alternate way for bacteria growth are biofilms systems. A biofilm is a complex coherent structure of cells and cellular products which can grow as large, dense granules or attached on a static solid surface or attached on suspended carriers [17]. In biofilm systems, substrate (e.g. oxygen and nitrogen sources) have to cross the biofilm-liquid interface by diffusion to reach the microbial cells and be consumed. The depth of layer diffused by the substrate depends on the biofilm porosity, substrate concentration, mass transfer in the aggregate-liquid interface and the biofilm reaction rate. As a result, conditions in biofilm reactors are not homogeneous and by consequence organisms in the biofilm experience different conditions depending on the distance from the biofilm surface according to the diffusion gradients. In multi-species biofilm systems, this will lead to a biofilm with a layered structure, giving species with different ecophysiological characteristics the opportunity to survive. In this layered structure, organisms with higher growth rate like NOB in nitrification process will be found at the outside layer of the biofilm, whereas organisms with slower growth rate such as AOB will be

found in the inside layer [106]. As a result slower growing organisms will be more protected from external shear forces and are less likely to be washed out through detachment, hence AOBs are often grown in biofilm systems.

Compared to suspended growth systems, attached growth systems have extra advantages such as (i) higher settling velocity of solids (around 50 m/h compared to 5 m/h for suspended growth systems) which may lead to the elimination of clarification stage, (ii) smaller area requirements (iii) higher biomass concentration can be retained in the bioreactor without the need of biomass and effluent separation (around 30 kg/m<sup>3</sup> compared to 3 kg/m<sup>3</sup> for suspended growth systems), and (iv) higher sludge age with lower sludge production (several weeks). However, attached growth technologies might encounter some challenges such as (i) clogging of media pores due to biofilm growth, (ii) long start-up period due to biofilm formation, (iii) controlling biofilm thickness is difficult, and (iv) controlling substrate concentration and biomass distribution gradients due to larger size of biofilms (usually 0.5-3.0 mm compared to flocs usually 10-150 µm) and lower porosity which make the diffusional transport slower [17].

Attached growth systems are commonly used in biological treatment in the following cases [77]:

1. Diluted wastewater with high flowrates are to be treated due to high biomass retention in these systems. Otherwise in high substrate concentration ( $> 10$  g COD/L) and rapidly growing organisms biofilm formation is unnecessary as sufficient biomass will be formed to metabolize the substrate within short residence time.
2. Microorganisms which readily form biofilms are used
3. Processes that need to be operated with high biomass concentration without using settlers and biomass recirculation.

### **2.5.1 Biofilm processes**

Biofilm reactors could be either **fixed film reactors** (static biofilms) like trickling filter –the oldest form of biofilm reactors-, membrane bioreactors (MBR) or **suspended carriers reactors** (particulate biofilms) like moving bed biofilm reactor (MBBR), biofilm airlift suspension (BAS), biofilm up flow sludge blanket (USB) **(Figure 2-5)**.

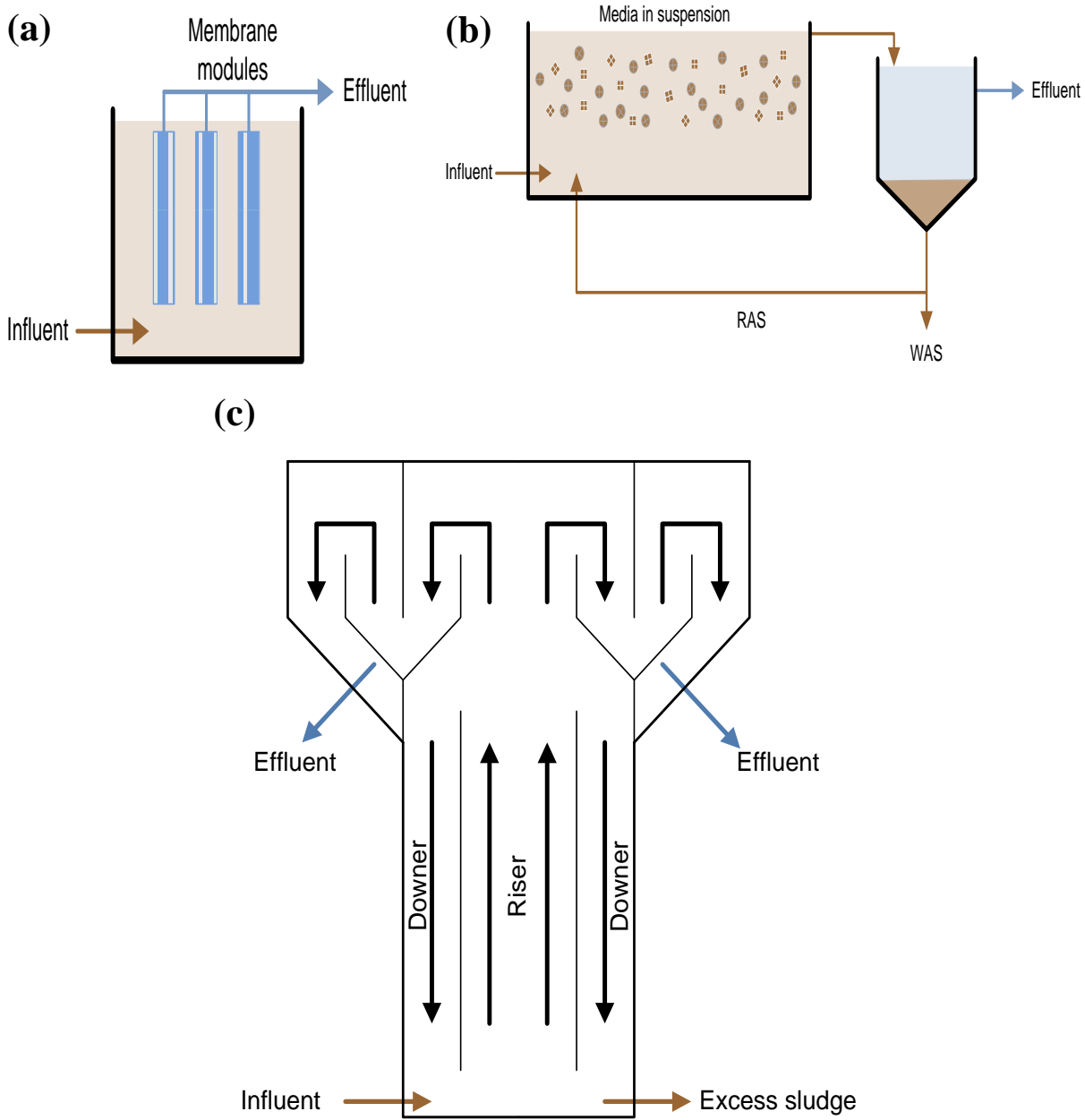

**Figure 2-5: Biofilm reactor configurations. (a) MBR; (b) MBBR; (c) BAS**

### **2.5.1.1 Fixed Film reactors (Static Biofilm)**

In fixed film reactors, the biomass is attached to the carrier that is retained fixed in the reactor. These systems are characterized by their simple configuration and low maintenance cost. On the other hand, the biofilm surface area of these reactors does not exceed  $200 \text{ m}^2/\text{m}^3$ .

#### **2.5.1.1.1 Membrane Bioreactor (MBR)**

Membrane bioreactor (MBR) technology (**Figure 2-5a**) is a reliable process for wastewater treatment that has become increasingly used in the past decade to overcome many of the limitations of conventional systems. These systems allow a higher biomass concentration to be maintained allowing smaller reactors to be used compared to conventional systems. Moreover, MBRs have been often operated with long SRTs which results in less sludge production. However, these systems have some drawbacks mainly for their high operating costs requirements. These costs include membrane cleaning to mitigate the fouling concerns, the energy costs for air scouring to control bacterial growth on membrane surface and the possible usage of chemicals to produce biosolids acceptable for disposal to overcome the settleability issues.

MBRs systems have been adopted widely for nitrogen removal process. These systems avoid cell washout by maintaining complete biomass in the reactor which favors the growth of nitrifying bacteria and by consequence increase the nitrification

efficiency. Shen et al. (2014) investigated in their experiments the performance of a nitrification membrane bioreactor treating synthetic wastewater devoid of organic carbon at 30 °C [9]. An ammonium conversion rate of about 0.8 kg N/ (m<sup>3</sup>.d) was achieved through controlling DO concentrations in the range of 0.5-0.8 mg/L and pH in the range of 8.0-8.5. A hollow fiber ultrafiltration membrane module of 0.01 µm pore size and 0.1 m<sup>2</sup> effective area was submerged inside the reactor. It was physically flushed with highly pressurized water when the fouling rates were low and chemically cleaned the later days. The reactor was operated at HRT of 10 h and at a prolonged SRT. Different nitrogen loading rate were applied through different ammonium concentrations in the effluent. It was noted that nitrate dominated rather than nitrite during lower loading rate in the startup period which was attributable to the presence of NOB which decreased gradually with the increase of the loading rates most likely due to the low and steady levels of DO (0.3-0.5 mg/L) which inhibited the proliferation of NOB and by consequence resulted in nitrite accumulation. AOB domination in the reactor could be implied from the significant decrease of VSS concentrations observed in the first days of operations which is most likely referred to the extent loss of NOB. It was suggested that DO concentrations (0.5-0.8 mg/L) and pH (8.0-8.5) are significant key parameters for the NOB inhibitions. On average, 82% of the ammonium was converted to nitrite in this MBR reactor. Although, increasing ammonium loading rates resulted in nitrite

accumulation higher levels of nitrate were observed after increasing the loading rates to a certain level (when the ammonium concentrations in the influent were raised to higher than 400 mg/L).

Moreover, the effect of different nitrogen loading rates on AOB community was studied in a MBR treating anaerobically digested swine wastewater which is characterized by its high ammonium concentration and low carbon to nitrogen ratio [107]. The reactor was divided into 2 different zones a biofilm zone and a membrane zone with a recycle ratio of 400% between both zones. The biofilm zone was not aerated and was filled with polyethylene carriers of 95% porosity and 500 m<sup>2</sup>/m<sup>3</sup> surface area with a filling ratio of 50%. A PVDF membrane of 0.1 μm pore size and 0.14 m<sup>2</sup> was installed in the membrane zone which was physically cleaned with tap water and then submerged in NaClO<sub>3</sub> solution for the recovery of the flux. Water temperature was controlled at 25 °C while pH was not controlled but it was found to be in the range of 7.52-8.51 in the effluent. The reactor was operated under 4 stages with different total nitrogen loading rate 0.27, 0.11, 0.06 and 0.06 kg N/ (m<sup>3</sup>.d) respectively and different COD to TN ratio and BOD to TN that ranged from 1.78 and 0.3 in lower ammonium loading rates to 8.76 and 3.02 in higher ammonium loading rate respectively. The corresponding HRT for the 4 stages was 8, 8, 5 and 3 days respectively. SRT was maintained at 90 days on average by discharging an amount of the SS from the membrane zone every day. The biofilm zone was not

aerated and low DO concentration was detected due to the recycle flux for the membrane zone while DO concentrations was high in the membrane zone ( $> 5.0$  mg/L) for membrane scouring purposes. It was noted that ammonium removal rate were higher at lower loading rates reaching 99.63% in stage IV most likely due to the increase in COD/TN and BOD/TN ratios to  $8.76 \pm 0.30$  and  $3.02 \pm 0.09$  respectively which was in the optimal range reported by Zhang et al. (2013) and Kishida et al. (2003) for achieving highly efficient removal of TN for swine wastewater treatment (3.0-4.5 for BOD/TN) [108], [109]. On the other hand, FA concentrations were lower than the range reported in the literature. Moreover, the ammonium nitrogen concentrations had a significant influence on the AOB diversity. *Nitrosomonas eutropha* and *Nitrosomonas* sp. OZK11 were the dominant AOB species during the experiment. At high ammonium concentrations, *Nitrosomonas eutropha* was the dominant AOB species while with the decrease of ammonium concentrations and the increase of C/N ratio the AOB community diversity decreased where *Nitrosomonas eutropha* started to disappear and *Nitrosomonas* sp. OZK11 became the dominant AOB species and played a significant role in oxidizing ammonium. The aforementioned effect could be referred to the low affinity for ammonium of *Nitrosomonas eutropha* which allowed it to perform under high ammonium concentration but when the ammonium concentration in the influent decreased it was gradually eliminated and only

Nitrosomonas sp. OZK11 with high affinity for ammonium had high conversion efficiency.

#### **2.5.1.1.2 Fixed Bed Bioreactor (FBB)**

The performance of an up-flow fixed film bioreactor treating low C/N synthetic wastewater in partial nitrification was investigated under oxygen limiting conditions [110]. The FBB was filled with a media of uniformly sized pieces of refractory bricks. The reactor was seeded with biomass from an activated sludge process treating nitrogenous coke wastewater and fed with synthetic wastewater devoid of any organic carbon. The reactor was initially operated under fed batch mode at HRT of 12 h for the development of the biofilm for 90 days then switched to continuous feeding mode for the rest of the experiment. The reactor temperature and pH were controlled at  $30 \pm 2$  °C and  $7.5 \pm 0.2$  respectively. The reactor was operated under three consecutive stages. During stage I (startup period), the reactor was fed with ammonia and nitrite at a ratio of 1:2 and the DO in the feed was  $4.2 \pm 0.3$  mg/L. Complete nitrification was achieved and no nitrite accumulation occurred in the reactor. During stage II, ammonia loading rate was increased and nitrite loading rate was decreased gradually till it was eliminated in the feed to reduce the substrate for NOB and to make the entire DO in the feed available for AOB and by consequence washout NOB. As a result, ammonia oxidation rate increased however nitrite oxidation rate also increased even after the elimination of nitrite loading in

the feed which indicates the occurrence of complete nitrification. That was attributed to the arrangement of AOB and NOB in the biofilm. AOB located in the outer layer consumes ammonia from the feeding and converts it into nitrite which diffuses into the inner layers of biofilm where NOB are located which by its turn convert it into nitrate. Stage III aimed to achieve partial nitrification through reduce DO concentrations in the feed. Firstly, DO was reduced from  $4.2 \pm 0.3$  mg/L to  $2.2 \pm 0.3$  mg/L which resulted in the increase of nitrite accumulation rate from 11% to 65% of the total nitrite and nitrate however a significant amount of nitrate was still present in the effluent. Therefore, the feed DO concentration was further reduced to  $1 \pm 0.1$  mg/L. A dramatic fall in ammonia oxidation rate was noted with the reduction of DO but after 3 months of operation it recovered gradually. This could be referred to a reduction in AOB and NOB activity due to the sudden DO limiting conditions but after a period of operation AOB got adapted to the limitation of DO and recovered its activity. Subsequently, the effect of HRT under DO limiting conditions was investigated and HRT of 18 h was revealed to be the optimum. In the end of stage III, ammonia oxidation rate efficiency reached more than 90% and a nitrite accumulation rate of 85% was reached in the final effluent. It can be revealed from this study that DO concentration has a crucial effect in the proliferation of AOB and washout of NOB.

Moreover, Liang et al. (2011) conducted their experiment to optimize partial nitrification in a fixed bed biofilm reactor treating synthetic wastewater [111]. The reactor was packed to 80% capacity with a mixed carrier material of hollow polyhedron polyethylene ball of  $460 \text{ m}^2/\text{m}^3$  specific area and sponge rectangle cubes of 60-80 pores per inch at a 1:1 volumetric ratio. The reactor was seeded with sludge from an ethanol wastewater treatment plant and the carrier media was inoculated in that seed for 48 h. The reactor was fed from the top of the mixed culture with synthetic wastewater with  $\text{NH}_4\text{Cl}$  as main substrate along with other minerals devoid of any organic matter except for the start-up period. Temperature was controlled at  $30 \pm 1 \text{ }^\circ\text{C}$ . The experiment was run under 3 stages. The first stage (startup period) aimed to cultivate the nitrifying biofilm on the surface of the media. To accelerate the biofilm formation, glucose was added to the feed to stimulate heterotrophic biofilm formation and by consequence providing nitrifying biofilm a surface to form on. Moreover glucose is biologically metabolized and produce carbon dioxide which is used by nitrifiers as carbon source. As expected, glucose stimulated the nitrifying biofilm formation and after a short period a thin layer of biofilm was observed on the media surface. Subsequently, ammonia concentration in the feed was increased gradually from 41.6 mg/L to 262.6 mg/L at the end of the stage. DO concentration and pH were maintained during the whole stage at 0.5-0.8 mg/L and  $7.8 \pm 0.2$  respectively. At ammonia concentration in the range of 41.6 mg/L to 103.5 mg/L

and HRT of 12 h, no nitrite accumulation occurred. After raising ammonia concentration to the range of 115.8 to 163.2 mg/L and decreased the HRT to 10 h, nitrite started accumulation and reached 83% of the total nitrite and nitrate produced. A further increase of ammonia concentration to 206.4-262.6 mg/L resulted in the conversion of the majority of ammonia to nitrite which its accumulation rate was above 85% of the total nitrite and nitrate in the effluent. The second stage aimed to investigate the effect of HRT and alkalinity on partial nitrification. To evaluate the HRT effect, the reactor was operated under 3 HRT of 16, 12 and 8 h through increasing influent volume with an ammonia concentration of 130 mg/L. A maximum ammonia oxidation to nitrite of 75% was reached at HRT of 16h while decreasing the HRT resulted in lower nitrite accumulation. Moreover, the reactor was operated under enough, half and zero alkalinities in the influent. It was revealed that alkalinity has a significant effect on nitrite accumulation. At significant alkalinity, ammonia removal efficiency reached 80% and nitrite to ammonia ratio reached 3.4 whereas decreasing alkalinity to half resulted in a drop in ammonia removal to 58% as well as a decrease in nitrite to ammonia ratio in the range of 1.06 to 0.97. Furthermore, zero alkalinity led to a sharp drop in ammonia removal to reach 33%. This effect could be referred to the decrease of pH in the reactor which accompanied the decrease of alkalinity and inhibited the AOB activity.

### **2.5.1.2 Suspended Carriers reactors (Particulate Biofilm)**

The alternate system for the growth of the biomass is to be formed attached to carriers that are kept in suspension (particulate biofilms). This suspension cannot be attained using mechanical mixing due to the high shear forces around the stirrer blades that may damage the biofilm formation [77]. Some examples for these types of reactors are Biofilm fluidized bed reactors (BFB), biofilm upflow sludge blanket (USB), biofilm airlift suspension (BAS) and moving bed biofilm reactors (MBBR). IN BFB and USB biofilm are kept in suspension through the upflowing influent while in BAS suspension is maintained through pumping air to the system. For anaerobic processes, BFB and USB are most commonly used whereas in aerobic processes BAS and MBBR are most feasible.

#### **2.5.1.2.1 Moving Bed Biofilm Reactor (MBBR)**

Moving Bed Biofilm (MBBR) reactors (**Figure 2-5b**) have been increasingly adopted for nitrogen removal in wastewater treatment. The MBBR process is a biofilm process that combines advantages of both suspended growth systems and conventional fixed film reactors. The biomass can either reside in suspended microbial assemblages as flocs or as biofilm attached to the media. Another advantage of MBBR is that the reactor liquid is totally mixed which eliminate the presence of unused space and the need for recycled sludge. The filling fraction of

carriers inside the reactor may be controlled but it is recommended that it does not exceed 70% to allow the carriers to move freely inside the reactor [112].

For the evaluation of MBBRs performance, partial nitrification-denitrification process has been used for synthetic wastewater treatment in two MBBRs in series one anoxic for partial denitrification process and the other aerobic for partial nitrification process followed by a settler [11]. An average removal efficiency of total nitrogen and ammonia of 98.23% and 99.75% respectively was reached during high ammonium load and low oxygen concentration. Polyethylene carriers of 0.95 g/cm<sup>3</sup> density were used with a 50% filling ratio in the aerobic reactor which allowed a specific biofilm surface area of 250 m<sup>2</sup>/m<sup>3</sup> and a total biofilm surface area of 2.5 m<sup>2</sup>. Complete mixing was provided by a mechanical stirrer and temperature was kept at 28.5 ± 1 °C using a water bath. The system was seeded from a municipal wastewater treatment plant and fed with synthetic wastewater with COD, NH<sub>4</sub> and PO<sub>4</sub>-P concentrations of 300-2000 mg/L, 25-250 mg/L and 5-50 mg/L respectively. For startup period, the reactor was operated at low ammonium loading rate (25 mg-N/L) and DO concentration at the range of 1.0-1.5 mg/L at HRT of 20 hrs. A gradual increase of ammonium was noticed which represented an indication for the growth of nitrifying bacteria. To test the effect of DO concentration and ammonia loading rate on partial nitrification, DO ranged in the aerobic from 0.5 to 3.3 mg/L and ammonium loading rate from 0.1-4.43 g-N/(m<sup>2</sup>.d.). The maximum ammonium

removal rate was 2.98 g-N/m<sup>2</sup>d and was reached when the influent NH<sub>4</sub>-N concentration on the biofilm surface area in the aerobic reactor was 4.43 g NH<sub>4</sub>-N/(m<sup>2</sup>.d.) at ammonium loading rate of 250 mg-N/L and DO concentration in the range of 1.0-1.5 mg/L. At the aforementioned conditions, nitrite accumulation rate reached 83% in the aerobic reactor. It was noted that although increasing ammonium loading rate resulted in an increase in ammonium removal rate, at some point increasing ammonium loading rate caused a deterioration in nitrification rate. The aforementioned deterioration is referred to the increase in free ammonia (FA) and free nitrous acid (FNA) concentrations.

#### **2.5.1.2.2 Biofilm Airlift Suspension (BAS)**

Airlift reactors is usually composed of two connected parts, a riser and a downcomer (**Figure 2-5c**). Gas is pumped from to the bottom and moves upward till it exists from the top through riser. Then air recirculate through the downcomer and provide aeration inside the reactor. The difference in density between the riser and the downcomer is what makes the liquid circulate between the two parts [113]. BAS reactors are preferred in aerobic processes over aerated Fluidized Bed Bioreactors (FBBR) reactors due to its simple configuration for providing aeration inside the reactor. In FBBR, large amounts of oxygenated water must be recirculated over the bed which usually causes hydraulic problems beside extra pumping costs.

Choi and Ahn (2014) compared the performance of a biofilm airlift suspension reactor and a suspended growth CSTR in partial nitrification treating wastewater produced from the dewatering of anaerobically digested sludge [6]. The suspended growth reactor (SG) was designed as CSTR without recycling whereas the attached growth reactor (AG) with crumbled tires and activated carbon media with 1500 m<sup>2</sup>/m<sup>3</sup> surface area and 0.0958 g of average particle weight at a filling ratio of 50%. The two reactors were seeded with activated sludge from a municipal wastewater treatment plant with a VSS to TSS ratio of 75%. Aeration was provided from the bottom of the reactor through air diffuser at 200 mL/min. Temperature was controlled in both reactors at 30 ± 2 °C whereas pH and DO were not controlled. The alkalinity to ammonia ratio was around 3.9 mg CaCO<sub>3</sub>/ mg NH<sub>4</sub>-N in the influent. Both reactors were run at three phases with different nitrogen loading rate ranging from 394 ± 12 to 1188 ± 9 mg N/l.d for SG reactor and 788 ± 24 to 2376 ± 18 mg N/l.d for AG reactor. HRT was controlled for to three phases at 24, 16, and 8 h for the SG reactor and 12, 6 and 4 h for the AG reactor respectively. During the three phases, the nitrogen production rate was 58-255 mg NO<sub>2</sub>-N/L (nitrite accumulation rate (NAR) = 14.7% to 64.7%) for SG reactor and 145-290 mg NO<sub>2</sub>-N/L for AG reactor (NAR= 36.7% to 73.7 %) while the nitrate production rate for both reactors was 3-49 mg NO<sub>3</sub>-N/L and 10-63 mg NO<sub>3</sub>-N/L for SG reactor and AG reactor respectively. The maximum nitrite accumulation rate for SG reactor was 64.7

$\pm 12.3 \%$  and occurred at NLR of  $394 \pm 12 \text{ mg N/(L.d.)}$  and HRT of 24 h whereas the maximum nitrite accumulation rate was  $73.7 \pm 4.5 \%$  and occurred at NLR of  $788 \pm 24 \text{ mg N/(L.d.)}$  and HRT of 12 h. The pH and DO in the effluent of AG reactor were in the range of  $6.07 \pm 0.23$  to  $7.89 \pm 0.11$  and  $3.90 \pm 0.18$  to  $6.11 \pm 0.51 \text{ mg O}_2/\text{L}$  respectively which was lower than that in SG reactor which was in the range of  $7.15 \pm 1.07$  to  $8.51 \pm 0.09$  and  $5.92 \pm 0.21$  to  $6.19 \pm 0.29 \text{ mg O}_2/\text{L}$  for pH and DO respectively. It was noted that a stable biofilm formation occurred in the AG reactor a higher AOB biomass retention than of that of SG reactor which resulted in more ammonia and bicarbonate alkalinity in AG reactor than in SG reactor. On the other hand, it was noted that AG reactor produced 66% less biomass in the effluent than the SG reactor. From the aforementioned results, it was deduced that AG reactor provided a higher nitrite accumulation rate than SG reactor under same configuration most probably due to the higher biomass retention, higher substrate rate and mass transfer. It also was suggested that the optimum nitrogen loading is  $0.42 \text{ g N/ (L.d.)}$  for the SG reactor and  $0.76 \text{ g N/ (L.d.)}$  for the AG reactor.

### **2.5.2 Granular processes**

Aerobic granular sludge can be used as an alternative technology to conventional activated sludge processes in wastewater treatment. Aerobic granulation was first reported by Mishima and Nakamura (1991) in an aerobic upflow sludge blanket reactor treating municipal wastewater [114]. Aerobic granules

are denser aggregates with higher diameter and density compared to conventional flocs which allow a faster settling and by consequence a higher level of biomass retention. The aforementioned characteristics lead to a reduction of capacity requirements and the ability to treat wastewater with higher loading rates without the need of external settler due to the ease of biomass separation in the same reactor. However, granular reactors have some drawbacks in the stability of long term operations. Aerobic granules can be a promising technology to achieve partial nitrification if appropriate configuration is to be developed. Aerobic granulation for achieving partial nitrification and accumulating AOB could be operated in either SBR reactors or CSTR reactors.

#### **2.5.2.1 SBR Granular reactors**

Recently, achieving partial nitrification through using aerobic granulation technology in SBR have been adopted by several studies. Li et al. (2013) adopted aerobic granulation technology to cultivate granule sludge for accumulating AOB in a SBR reactor [115]. The SBR reactor had a cycle of 12 h consisted of 1 min of feeding, 11h and 53-57 min of aeration, 1-5 min of sludge settling depending on sludge settling properties and amount of biomass required to be discharged and 1 min of effluent withdrawal. After each cycle slow settling flocs were discharged to avoid the competition between these small sludge flocs in suspended growth and dense granules for substrate uptake and make the substrate more available for uptake

by the attached growth dense granules, hence stimulating the granulation. The amount of biomass discharged was calculated to maintain a VSS concentration of 2000 mg/L in the bioreactor. A 30 min of settling after flocs discharging was allowed for the remaining sludge to settle before effluent withdrawal. The bioreactor was seeded with nitrifying activated sludge from a fermentation process and fed with synthetic wastewater with ammonium and phosphate concentration of 400 mg N/L and 30 mg P/L. Furthermore, filtered clean seawater was added to the medium to increase its salinity to 1% to supply inorganic salts for the biomass and no organic substrate was added in the feed. DO concentration, pH and temperature were controlled at 2-4 mg/L, 7.5 and 20-22 °C respectively. After 2 weeks of operation, the granulation formation was clear and the mean size of the sludge increased from 181 to 250 µm and it continued to increase gradually till it reached around 330 µm which was probably due to the selective discharge of loose sludge flocs. Moreover, F/M ratio was adjusted during different stages of cultivation, it was increased in the first stage to fasten granules formation then reduced to allow stabilization of smaller granules. It was noted that before granules formation complete nitrification took place in the bioreactor with low level of nitrite in the effluent. With the granules formation, partial nitrification was achieved with over than 90% nitrite accumulation in the effluent. The larger size of granules led to a lower DO concentration within the granules which promoted AOB accumulation. The overall ammonia removal rate

was 99% with only 4 mg N/L of ammonia concentration in the effluent. The results of this experiment revealed that aerobic granulation could lead to nitrite accumulation through the selective of slow settling sludge flocs and high ammonia loading in the influent.

### **2.5.2.2 CSTR Granular reactors**

Regarding the poor stability of aerobic granulation processes in long term operation, continuous flow process could be preponderant than SBR in partial nitrification. Wan et al. applied a novel strategy to achieve stable partial nitrification in a continuous flow reactor using aerobic granules after being cultivated in a SBR reactor [97]. First, granules were cultivated in a SBR reactor at high COD of 3:1 acetate: propionate. The reactor was inoculated with seed sludge collected from a recycled sludge with SS of 6000 mg/L and fed with synthetic wastewater that contains 200 g/L  $\text{NH}_4\text{Cl}$  as ammonia source. The reactor was run for 6 cycles a day, each cycle consisted of 3 min feed, 227 min aerobic reaction and settling, 5 min decanting and 5 min idle. After 16 days of cultivation, aerobic granules were inoculated to a continuous flow reactor with SS of  $820 \pm 30$  mg/L. The reactor with same feed as the parent reactor but with variable COD during operation. DO, pH, HRT and temperature were kept at 7 mg/L,  $7.2 \pm 0.1$ , 12 h and  $28 \pm 1$  °C respectively. The CSTR were operated in 3 stages of 20 days each at influent COD of  $1500 \pm 100$ ,  $750 \pm 50$  and  $350 \pm 50$  mg/L. During first stage, ammonia removal rate increased

gradually till it reached 60% with nitrite accumulation of 88-96 % of the total nitrite and nitrate produced. In stage II, decreasing C/N ratio from 28/1 to 14/1 resulted in enriching AOB and washing out NOB however partial nitrification was not enhanced. After decreasing COD in stage III,  $400 \pm 50$  mg/L  $\text{HCO}_3^-$  was added as inorganic source of carbon to maintain total carbon to nitrogen ratio at 14/1 which resulted in an increase in partial nitrification to reach 85-90% after 6 days. In cultivation stage in SBR reactor, almost no AOB was present but it started to accumulate after a period of operation in continuous flow reactor. High COD in the initial period of operation stimulated the granule formation then decreasing its concentration and adding instead inorganic carbon source resulted in losing part of the granules but enriched AOB and inhibited NOB in the remaining granules which led to achieving partial nitrification in a short period of 52 days (16 days in SBR and 36 days in CSTR).

# **CHAPTER 3**

## **DEVELOPMENT OF PARTIAL NITRIFICATION AS A FIRST STEP OF NITRITE SHUNT PROCESS IN A SBR USING AOB THROUGH DO LIMITATIONS CONDITIONS CONTROLLED BY MIXING REGIME\***

### **3.1 Introduction**

In the partial nitrification process, the ammonia is oxidized to hydroxylamine ( $\text{NH}_2\text{OH}$ ) catalyzed by the enzyme ammonia monooxygenase (AMO). This step requires one molecular oxygen and two extra electrons, while the second step consists of the further oxidation of hydroxylamine catalyzed by the hydroxylamine oxidoreductase (HAO) enzyme generating 4 electrons. Two of them are returned to ammonia monooxygenase to support the first step of nitrification [35]. Furthermore, the remaining two electrons serve for the cell synthesis. Through the electron transport, 1.65 electrons are passed to the terminal electron acceptor  $\text{O}_2$  which is then reduced to form  $\text{H}_2\text{O}$ , while the remaining 0.35 electrons are used for the reduction of  $\text{NAD}^+$  to  $\text{NADH}$  through 'reverse electron flow' which has been suggested to be performed by the embedded electron carrier  $\text{NADH}$  dehydrogenase [36].

Recently, partial nitrification has been adopted widely either for the nitrite shunt process or intermediate nitrite generation step for the Anammox process. However, the majority of the studies in the literature have targeted to achieve an effluent of  $\text{NO}_2:\text{NH}_4$  molar ratio of 1.31 suitable for subsequent Anammox process [2]. However, fewer studies have targeted to reach a complete oxidation of ammonia to nitrite (full partial nitrification) as a first step for the nitrite shunt process **(Table 3-1)**.

To achieve nitrite accumulation and selectively inhibit NOB, several strategies has been used including (i) maintaining low dissolved oxygen concentration, (ii) controlling free ammonia (FA) and free nitrous acid (FNA) concentrations through temperature/pH, and (iii) reducing the hydraulic retention time (HRT). Performing partial nitrification through controlling the DO concentration in suspended growth system is based on the differences between the Monod saturation constant of oxygen for AOB (0.3 mg/L) and NOB (1.1 mg/L) indicating the higher affinity of oxygen for AOB over NOB [48]. Furthermore, AOB and NOB are sensitive to free ammonia (FA) and free nitrous acid (FNA) concentrations. The inhibition limit for NOB is 0.1-1.0 mg N/L, whereas 10-150 mg N/L of free ammonia is required to inhibit AOB [116]. Additionally, NOB is more sensitive to free nitrous acid compared to AOB. FNA concentration of 0.4-1.7 mg-N/L resulted in a 50% reduction in AOB activity, while low concentrations of 0.01-

0.2 mg-N/L started to inhibit NOB [117]. Based on the fact that pH and temperature influence the equilibrium of FA and FNA, regulating these parameters can be crucial for achieving partial nitrification. Moreover, shortening HRT for AOB is an effective method to control the partial nitrification due to limited doubling time for AOB (7-8 h) compare to 50% more for NOB [118]. The DO limitation is considered being the most feasible strategy for sustainable partial nitrification. However, due to the complexity of maintaining a uniform specific DO concentration, different strategies are required to maintain low DO concentrations and minimize the energy requirement during the SBNR. Therefore, 3 methods for aeration control during SBNR have been developed including (i) DO control using DO probe to control the Variable Frequency Drive (VFD) connected to the system blower, (ii) Ammonia Based Aeration Control (ABAC) using an ammonia probe to predict the required air flow rate according to the ammonia concentrations present in the system, and (iii) Ammonia vs.  $\text{NO}_x$  (AvNTM) Control, which nitrifies only the amount of ammonia that can be denitrified afterwards. However, slow mixing speed accompanied with low aeration requirements could result in some biomass settling during the reaction time.

**Table 3-1: Ammonia removal efficiency and nitrite accumulation rate in Partial nitrification SBRs**

<b>Control strategy</b>	<b>Control parameter value</b>	<b>Nitrogen loading rate (NLR) Kg N/ (m<sup>3</sup>.d.)</b>	<b>Influent Ammonia conc. (mg NH<sub>3</sub>-N/L)</b>	<b>Ammonia Removal Efficiency (%)</b>	<b>Nitrite acc. Rate (NAR) (%)</b>	<b>Reference</b>
<b>DO</b>	DO = 0.5-1.5 mg O <sub>2</sub> /L	N/A	96.6 ± 0.05	99 %	62 %	[3]
			127.9 ± 0.05	99 %	66 %	
			219.1 ± 0.05	91 %	61 %	
			254.9 ± 0.05	72 %	22 %	
<b>Temperature pH HRT</b>	T= 28 °C	0.13	98	98 %	78 %	[119]
	pH = 8.5	0.13		95%	82 %	
	HRT = 20 h	0.12		97 %	87 %	
<b>pH DO</b>	pH = 8.2-8.5	0.45	300	95 %	32 %	[10]
	DO = 0.5-1.0 mg/L			99.1%	91.5%	
<b>FA &amp; FNA via temperature</b>	T = 25 °C	1.33	5975 ± 213	55 %	99 %	[4]
	T = 35 °C	0.50		56 %	99.2 %	
<b>FA via pH</b>	pH = 6.8 -7.1	1.00	1440	50 %	99.95%	[102]
<b>FA via pH</b>	Fed batch pH = 7 – 7.5	1.17	1761	64.5 %	100%	[5]
	Step feed pH = 7 – 7.5	1.34	2009	62.5 %	100 %	
<b>DO</b>	DO = 0.5-1.0	0.86	1293	36.5 %	99.6 %	[120]
	DO = 1.0-2.0	0.83	1253	47.8 %	99.6 %	
	DO = 2.0-3.0	0.87	1307	59.2 %	97.3 %	
	DO = 3.0-4.0	0.86	1295	32.2 %	88.8 %	

Thus, a novel strategy has been developed to control the DO to achieve a higher partial nitrification rate at a maximum NLR targeting complete ammonia oxidation to nitrite as a first step of the nitrite shunt process and attain an effluent suitable for the subsequent heterotrophic denitrification in a suspended growth system using SBR process. The novel strategy depends on using a constant air flow rate with a variable mixing speed according to the DO concentrations inside the reactor to maintain the required DO for the whole operation period while assuring that the agitation is always working at the maximum available speed and by consequence preventing any biomass settling during the reaction time. The SBR was operated with a stepwise increase in influent ammonium concentration reaching a concentration of 1000 mg NH<sub>3</sub>-N/L at NLR of 1.2 kg/ (m<sup>3</sup>.d). Additionally, the different parameters affecting partial nitrification performance were evaluated.

## **3.2 Materials and Methods**

### **3.2.1 Reactor design**

The SBR, depicted in **Figure 3-1a**, comprises of 2 L glass reactor with a height of 25 cm and an internal diameter of 10 cm corresponding to a working volume of 1700 ml. The reactor was fed from a 5 L feeding tank using a peristaltic pump (Masterflex L/S Digital Pump System with Easy-Load II Pump Head, Germany). The effluent was discharged from the middle of the tank during the

decant phase and collected into a discharge tank to monitor the sludge washout and calculate the solid retention time (SRT). The experiment was operated and controlled using a control device (BioFlo<sup>®</sup> 115 Benchtop Fermenter & Bioreactor, New Brunswick, USA) as shown in **Figure 3-1b**. The temperature was controlled using a heating jacket covering the reactor from outside. The mixing was carried out by a mechanical stirrer connected to the control device to adjust the mixing speed according to the DO concentration during the reaction phase. The air was introduced from the bottom of the reactor using an air pump and the DO was monitored through a DO probe connected to the control device. DO during the partial nitrification stages was controlled by a new strategy using a variable mixing speed of the reactor mixing and the airflow was constant during all aerobic reaction phases. DO was set as a cascade with the agitation through the device. DO was sensed by the DO electrode and its control was maintained by changing the speed of agitation. At the beginning of the cycle, when the oxygen demand was high, the device increased the mixing speed. Later, while the oxygen demand decreased by time, the device kept decreasing the agitation speed to maintain the same DO concentration inside the reactor for the whole operation duration. In order to control the SBR phases, all power connections were controlled using a power timer according to the running phase, DO requirement, and mixing requirement.

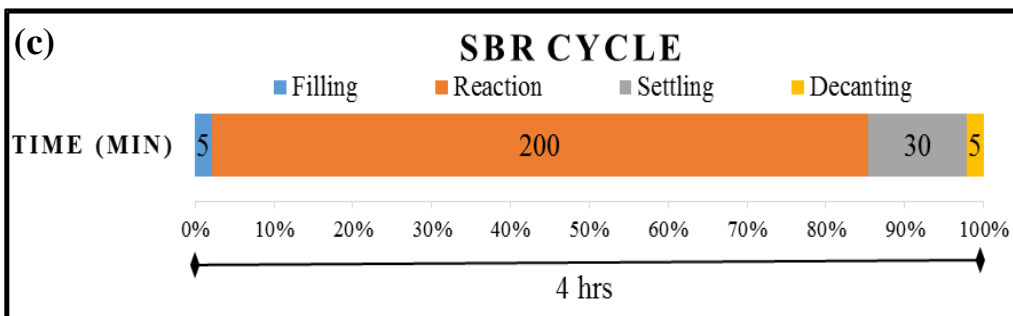
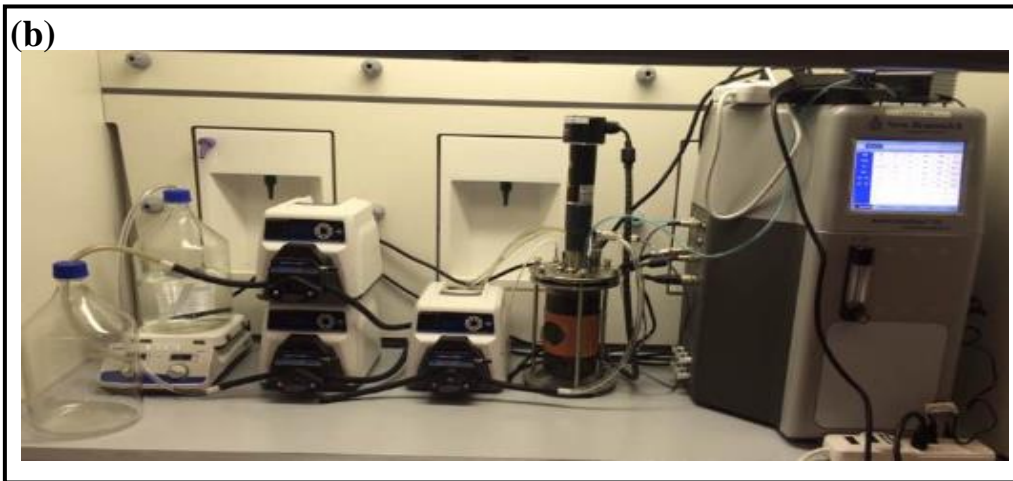
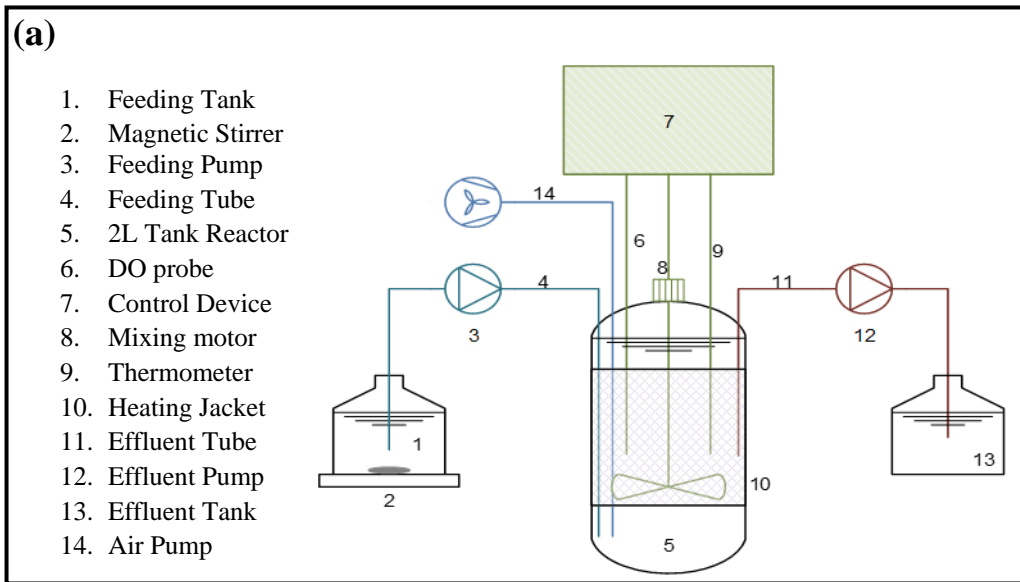

**Figure 3-1: (a) Schematic Diagram of the SBR used in this experiment; (b) BioFlo<sup>®</sup> 115 Benchtop Fermenter & Bioreactor during operation; (c) SBR's cycle for Partial Nitrification process**

### 3.2.2 Operational Conditions

The SBR cycle had a total duration of 4 hours consisted of 5 mins of filling, 200 mins of aerobic reaction, 30 mins of settling, and 5 mins of decanting as shown in **Figure 3-1c**. The temperature was maintained at 31°C and pH was controlled through the alkalinity concentration in the feed to maintain it in the range of 7.9-8.2, which was reported to be the optimum range for *Nitrosomonas* (dominant species of AOB) [121].

The reactor was run in three stages with different operational conditions shown in **Table 3-2a**. The ammonia concentration in the feed was increased gradually during the process in order to allow the biomass to adapt to the increased NLR and prevent any shock effect. The first stage (start-up period) aimed to attain complete nitrification through running the reactor at a high DO concentration (up to 3.5 mg/L) to accumulate the nitrifying bacteria (AOB and NOB) and washout the heterotrophic bacteria under organic starving phase. In stage II, the DO concentration was decreased to 0.5-0.8 mg/L to stimulate the growth of AOB, inhibit NOB and consequently accumulate nitrite. HRT also increased from 12 to 16 h to enhance the bioreactor capability of receiving higher ammonium concentration without increasing the NLR. In Stage III, HRT was further increased to 20 h and the DO concentration was elevated to 0.6-1.2 mg/L with the increase in the ammonium

concentration in the influent during this stage to correspond the higher aeration requirement of the higher NLR introduced.

### **3.2.3 Feeding solution and seeding sludge**

A synthetic municipal wastewater (SMW) was prepared using deionized water combined with concentrated stock solutions of  $\text{NH}_4\text{Cl}$  (as nitrogen source),  $\text{KH}_2\text{PO}_4$  (as phosphorus source), and  $\text{NaHCO}_3$  (as alkalinity source) as well as a mineral stock solution at a volumetric ratio of 1:0.001 as shown in **Table 3-2b**. The trace concentrated stock solutions contained 990 mg  $\text{MnCl}_2 \cdot 4\text{H}_2\text{O}/\text{L}$ , 500 mg  $\text{FeSO}_4 \cdot 7\text{H}_2\text{O}/\text{L}$ , 430 mg  $\text{ZnSO}_4 \cdot 7\text{H}_2\text{O}/\text{L}$  and the mineral salt stock solution contained 190 mg  $\text{NiCl}_2 \cdot 6\text{H}_2\text{O}/\text{L}$ , 220 mg  $\text{Na}_2\text{MoO}_4 \cdot 2\text{H}_2\text{O}/\text{L}$ , 250 mg  $\text{CuSO}_4 \cdot 5\text{H}_2\text{O}/\text{L}$ , 240 mg  $\text{CoCl}_2 \cdot 6\text{H}_2\text{O}/\text{L}$ , 210 mg  $\text{MnCl}_2 \cdot 4\text{H}_2\text{O}/\text{L}$ , 19 mg  $\text{H}_3\text{BO}_4 \cdot 7\text{H}_2\text{O}/\text{L}$ , and 15 g  $\text{EDTA}/\text{L}$ . As evident from **Table 3-2b**, the SMW was devoid from any COD to control the growth of other bacteria (i.e. heterotrophic bacteria).

The SBR reactor was inoculated with enriched return activated sludge (RAS) from the Humber Municipal Wastewater Treatment Plant (WWTP), Toronto, Canada, with TSS and VSS concentrations of 16726 and 12240 mg/L respectively. The seed sludge was mixed for 3 days, after which the reactor was fed the SMW at a flow rate ranged based on the ammonia nitrogen loading rate as illustrated in **Table 3-2a**.

**Table 3-2: a) Detailed operational conditions during different stages of the SBR, (b) Influent characteristics for Synthetic municipal wastewater (SMW) and (c) Primer sets included in PCR assay**

(a)

Stage	HRT (h)	DO (mg/L)	NLR (Kg/ (m <sup>3</sup> .d.))	Influent ammonia (mg NH <sub>3</sub> -N/L)	Influent alkalinity (mg CaCO <sub>3</sub> /L)
I	12	1.5-3.5	0.3	149.5 ± 2.5	1338.0 ± 328.2
			0.4	245.9 ± 2.5	2712.9 ± 19.8
II	16	0.5-0.8	0.375	242.6 ± 1.5	2393.1 ± 42.9
			0.525	349.4 ± 2.7	3142.9 ± 262.3
			0.675	440.7 ± 3.8	3583.3 ± 51.9
III	20	0.6-1.2	0.6	497.6 ± 3.6	3991.4 ± 24.7
			0.72	601.4 ± 10.0	4818.6 ± 30.9
			0.66	529.4 ± 19.3	4263.9 ± 121.5
			0.84	700.6 ± 11.5	5881.1 ± 92.3
			0.96	788.1 ± 2.4	6845.0 ± 25.0
			1.08	901.5 ± 3.5	7805.0 ± 25.0
		1.2	990.0 ± 4.1	8531.1 ± 168.4	

(b)

Parameter	Concentration (mg/L)
NaHCO <sub>3</sub>	2500-16500
NH <sub>4</sub> Cl	600-4250
KH <sub>2</sub> PO <sub>4</sub>	100
MgSO <sub>4</sub>	40
CaCl <sub>2</sub>	50
Trace element	1 mL/L

(c)

Target Organism	Primer	Target Gene	Sequence	Reference
<b>β-subdivision of AOB</b>	CTO	16S rRNA	GGAGRAAAGCAGGGGATCG	[122]
	189fA/B RT1r	16S rRNA	CGTCCTCTCAGACCARCTACTG	
<b>AOB</b>	AmoA-1F AmoA-2R	amoA	GGGGTTTCTACTGGTGGT CCCCTCKGSAAAGCCTTCTTC	[122]
<b>Nitrospira spp.</b>	NSR1113F NSR1264R	16S rRNA	CCTGCTTTCAGTTGCTACCG GTTTGCAGCGCTTTGTACCG	[123]
<b>Nitrobacter spp.</b>	FGPS872 FGPS1269	16S rRNA	TTTTTTGAGATTTGCTAG CTAAAACTCAAAGGAATTGA	[123]
<b>All bacteria</b>	Primer 3F  Primer 2R	16S rRNA	CGCCCGCCGCGCGCGGGCGGCG GGGCGGGGGCACGGGGGG CCTACGGGAG GCAGCAG ATTACCGGGCTGCTGG	[122]

### 3.2.4 Analytical Methods

Influent and final effluent samples were collected in airtight bottles daily after the 6<sup>th</sup> cycle of the day, refrigerated at 4°C prior to analysis. Total suspended solids (TSS), and volatile suspended solids (VSS) were analyzed according to the Standard Methods (APHA, 1998). Alkalinity was measured by titration with 0.01 N H<sub>2</sub>SO<sub>4</sub> in accordance with the Standard Method no. 2320 (APHA, 1998). DO and pH were measured in the reactor using an installed Mettler-Toledo INGold Do Probe, (Mettler-Toledo, US) and pH-11 series pH/(mV· °C) meter (Hach HQ440d, US), respectively. HACH methods and testing kits (HACH Odyssey DR/2800) were used to measure total chemical oxygen demand (COD), soluble chemical oxygen demand (sCOD), total phosphorus (TP), NH<sub>3</sub>-N, NO<sub>2</sub>-N, NO<sub>3</sub>-N, and PO<sub>4</sub>-P.

The free ammonia (FA) and free nitrous acid (FNA) concentrations inside the SBR were estimated using (Eq. (3.1) and Eq. (3.2)) proposed by [116]:

$$FA \left( \frac{mg}{L} \right) = \frac{17}{14} X \frac{NH_3-N X 10^{pH}}{10^{pH} + \exp\left(\frac{6344}{273+T}\right)} \quad (3.1)$$

$$FNA \left( \frac{mg}{L} \right) = \frac{46}{14} X \frac{NO_2-N}{10^{pH} X \exp\left(-\frac{2300}{273+T}\right)} \quad (3.2)$$

The ammonia removal efficiency (ARE) and nitrite accumulation rate (NAR) were calculated according to (Eq. (3.3) and Eq. (3.4))

$$ARE (\%) = \frac{(NH_3-N)_{inf} - (NH_3-N)_{eff}}{(NH_3-N)_{inf}} \times 100 \quad (3.3)$$

$$NAR (\%) = \frac{(NO_2-N)_{eff}}{(NO_2-N)_{eff} + (NO_3-N)_{eff}} \times 100 \quad (3.4)$$

### 3.2.5 Molecular techniques

To test the presence of AOB and NOB during the different SBR stages, 2 samples were collected and analyzed using PCR. The first sample was taken from the effluent tank at day 80 to be used as a reference for the washed out biomass, whereas the second one was withdrawn from the reactor during the reaction time at the same day representing the biomass inside the reactor

#### 3.2.5.1 Genomic DNA extraction

1 mL of mixed liquor of each sample were transferred to microfuge tubes and centrifuged at 10000 rpm. DNA was extracted with DNA kit (Applied Biosystems, Foster City, CA), with the manufacturer's instructions. DNA concentration were determined in a Nanodrop ND-1000 UV spectrophotometer (Nanodrop Technologies, Wilmington, DE, USA).

#### 3.2.5.2 PCR identification for AOB

The presence of AOB and NOB were determined by PCR amplification on DNA extracts for the collected samples. All qPCR assays were performed in a 7500 PCR system (Applied Biosystems, Carlsbad, CA, USA) on MicroAmp optical 96-

well reaction plates covered with optical caps (Applied Biosystems, Carlsbad, CA, USA) using the primers shown in **Table 3-2c**.

### **3.3 Results and discussions**

#### **3.3.1 SBR performance**

As illustrated in **Table 3-2a**, the SBR system was operated in three stages starting with a complete nitrification stage at a high DO concentration to assure the accumulation of both nitrifying bacteria (i.e. AOB and NOB) and washout the heterotrophic bacteria under organic starving phase.

##### **3.3.1.1 Stage I: start-up period**

In the start-up period (Stage I), the DO concentration was set at 3.5 mg/L (at a mixing speed of 200 RPM and a higher air flow rate) to assess the availability of the nitrifying biomass in the seeded sludge and predispose it into a suitable environment in order to perform complete nitrification. This stage was run at HRT of 12 h and an ammonia concentration ranged from 150 to 250 mg NH<sub>3</sub>-N/L corresponding to a NLR of 0.3 and 0.4 Kg/ (m<sup>3</sup>.d), respectively.

As shown in **Figure 3-2b**, the complete nitrification was achieved after 5 days and the effluent ammonia concentration by the end of this stage; as shown in **Table 3-3**; was  $0.1 \pm 0.1$  mg NH<sub>3</sub>-N/L corresponding to an ARE of  $99.9 \pm 0.1\%$ , which indicates the presence of substantive nitrifying biomass in the seeded sludge.

During this stage, no considerable nitrite accumulation was noticed and a complete conversion of ammonia into nitrate was achieved. The nitrate concentration reached 236.9 mg NO<sub>3</sub>-N/L by the end of this stage implying the occurrence of complete nitrification.

### **3.3.1.2 Stage II: partial nitrification**

After a complete nitrification phases, DO concentration was decreased to 0.3-0.8 mg/L (at a mixing speed range of 100-300 RPM and a constant air flow) to maintain the nitrifying biomass at oxygen-limited conditions in order to promote the growth of AOB over NOB. This stage was operated at HRT of 16 h and a NLR of 0.375 Kg/ (m<sup>3</sup>.d).

Although the NLR was reduced, ARE also dropped to 65.4% after the first day of the operation owing to the change of the oxygen conditions. Moreover, this deterioration was accompanied with nitrite-build up and a decrease in the nitrate production. During the start-up of stage II, the nitrite concentration in the effluent jumped from 0.029 to 33 mg NH<sub>3</sub>-N/L, while nitrate concentration dropped from 236.9 to 96 mg NO<sub>3</sub>-N/L and achieved a NAR of 25.6%. As the experiment progressed, ARE was improved gradually to recover 100% ammonia removal. Furthermore, the nitrite-build up was enhanced simultaneously to reach a stable NAR of around 85% (by the end of NLR level). On the other hand, nitrate reduced progressively and settled below 30 mg NO<sub>3</sub>-N/L. Additionally, the high NAR was

accompanied with the deterioration of nitrate concentrations in the effluent after the decrease in the DO concentration proving the attainment of the DO limitation strategy in establishing partial nitrification and washout the NOBs.

After reaching a stable ammonia removal efficiency of 100%, the NLR was increased to 0.525 kg/ (m<sup>3</sup>.d) by increasing the influent ammonia concentration to 350 mg NH<sub>3</sub>-N/L. The increase in the NLR resulted in a decrease in the ARE to 71.5%, which may be referred to the biomass acclimation at the new NLR and the sudden increase of the free ammonia (FA) concentration, which appear to have an inhibitory effect on AOB [116]. Subsequently, a complete ammonia removal was achieved the effluent dropped to 0.0 mg NH<sub>3</sub>-N /L. Therefore, the nitrite concentration increased by 2 times to reach 287.2 mg NO<sub>2</sub>-N/L, corresponding to NAR of 92.9% with stabilization of nitrate concentration below 30 mg NO<sub>3</sub>-N /L.

In order to achieve the maximum NLR of the incubated AOBs, the NLR was increased to 0.675 Kg/ (m<sup>3</sup>.d), which instantly resulted in a similar drop in the ARE by 10% compared to the pervious NLR. Likewise, the SBR recovered its performance shortly and attained a 96.2% ARE. By the end of this stage, NAR was 93.9% with nitrite concentration up to 400 mg NO<sub>2</sub>-N /L, whereas nitrate concentration was still as low as 25 mg NO<sub>3</sub>-N /L.

**Table 3-3: Summary of Partial Nitrification SBR performance during all different stages**

Stage	NLR (Kg/ (m <sup>3</sup> .d.))	Effluent							ARE (%)	NAR (%)
		Ammonia (mg N/L)	Nitrite (mg N/L)	Nitrate (mg N/L)	Alkalinity (mg CaCO <sub>3</sub> /L)	pH	FA (mg/L)	FNA (mg/L)		
<b>I</b>	0.3	7.3 ± 5.7	0.24 ± 0.1	130.7 ± 4.3	272.8 ± 299.9	6.5 ± 1.1	0.02 ± 0.01	0.003	95.2 ± 3.8	0.2 ± 0.1
	0.4	0.1 ± 0.1	0.04 ± 0.1	236.8 ± 8.0	912.0 ± 49.3	8.4 ± 0.1	0.02 ± 0.02	0.0	99.9 ± 0.1	0.01 ± 0.01
<b>II</b>	0.375	7.7 ± 7.1	162.0 ± 18.3	34.4 ± 14.2	881.5 ± 42.34	8.0 ± 0.2	0.73 ± 0.67	0.012	96.8 ± 2.9	82.4 ± 7.7
	0.525	11.9 ± 16.5	264.9 ± 22.6	21.8 ± 5.3	754.7 ± 188.5	8.1 ± 0.2	1.05 ± 1.46	0.019	96.6 ± 4.7	92.2 ± 1.5
	0.675	21.3 ± 4.8	381.0 ± 6.5	25.8 ± 1.7	708.6 ± 69.3	7.8 ± 0.1	1.25 ± 0.35	0.042	95.2 ± 1.1	93.6 ± 0.5
<b>III</b>	0.6	13.4 ± 11.7	429.5 ± 18.5	26.1 ± 1.3	708.0 ± 140.5	7.9 ± 0.1	1.02 ± 0.92	0.040	97.3 ± 2.4	94.2 ± 0.5
	0.72	5.0 ± 8.7	558.4 ± 16.0	28.6 ± 2.7	685.6 ± 89.5	7.8 ± 0.1	0.32 ± 0.59	0.067	99.2 ± 1.5	94.9 ± 0.7
	0.66	0.11 ± 0.26	486.8 ± 26.4	27.1 ± 2.9	787.3 ± 23.5	7.9 ± 0.1	0.01 ± 0.0	0.036	99.9 ± 0.1	94.7 ± 0.7
	0.84	12.7 ± 17.6	642.4 ± 22.3	38.9 ± 5.4	894.4 ± 80.2	7.8 ± 0.1	1.04 ± 1.64	0.064	98.2 ± 2.5	94.1 ± 0.9
	0.96	11.0 ± 12.9	726.1 ± 21.2	41.5 ± 4.3	1097.3 ± 118.7	8.0 ± 0.1	1.05 ± 1.26	0.055	98.6 ± 2.7	94.3 ± 0.8
	1.08	11.4 ± 18.7	837.6 ± 19.3	46.9 ± 3.0	1247.3 ± 217.8	8.1 ± 0.1	1.32 ± 1.29	0.050	98.7 ± 2.1	94.7 ± 0.3
	1.2	14.3 ± 28.1	902.4 ± 23.5	66.8 ± 9.4	1449.2 ± 235.9	8.0 ± 0.1	1.51 ± 3.09	0.058	98.6 ± 2.8	93.0 ± 0.7

### 3.3.1.3 Stage III: stable partial nitrification under high NLR

At this stage, higher NLR was introduced to the reactor to assess the stability of applying the partial nitrification to wastewater of high ammonium concentrations. Correspondingly, DO concentration was increased to 0.6-1.2 mg/L (at a mixing speed range of 200-500 RPM and a constant air flow) to support the higher oxygen demand of high ammonia concentrations in the influent [124]. Additionally, HRT was stepped up to 20 h for the whole period of this stage.

Similarly to the previous results, increasing the ammonia concentration resulted in an immediate drop in ARE from 96.2 to 85.1% after the first day of the operation as shown in **Figure 3-2b**, however, increasing NLR did not affect the nitrite accumulation that was stable at the level of 93%. As the experiment progressed, ARE improved progressively to reach 99.7% with an increase in the average NAR to  $94.2 \pm 0.5\%$ . In order to study the effect of the increase in DO at the beginning of this stage, DO concentration was cut down back to 0.5-0.8 mg/L for 2 days. The results showed a drop of ARE from 99.7% to 94.9% as well as a drop of nitrite concentration in the effluent from 447 to 411 mg NO<sub>2</sub>-N /L.

On days 47-60th, ammonia concentration in the influent rose to 600 mg NH<sub>3</sub>-N /L that was equivalent to a NLR of 0.72 kg/ (m<sup>3</sup>.d). That means ammonia removal efficiency fell down after the first day of operation to 83.7% with NAR being almost stable at 93%. In the same manner, in the following days of operation a stable 100%

ammonia removal was achieved with NAR average of  $94.9 \pm 0.7\%$ . The observed drop in ammonia removal efficiency is consequence of the biomass adaptation for the higher NLR.

On days 61-74<sup>th</sup> and in order to study the effect of NLR decrease on ARE, ammonia concentration in the influent went down from 600 to 550 mg NH<sub>3</sub>-N /L. ARE remained stable at 100% implying that moving from higher to lower NLR does not affect the nitrogen removal performance due to the prior acclimation of the biomass to higher NLR. Moreover, further decrease in the influent ammonia concentration led to the same result. The NAR during this period also remained constant indicating the capability of the SBR to maintain the successful partial nitrification treating variable nitrogen loads in wastewater such as landfill leachates.

Then, ammonia concentrations in the influent increased back from 500 to 700 mg NH<sub>3</sub>-N /L (NLR of 0.84 kg/ (m<sup>3</sup>.d)). A significant fall in ARE was observed to 81.5% with a slight drop in NAR from 94.8% to 92.1% due to the sudden increase of NLR, however, ammonia oxidation has been recovered while the experiment progressed to reach 100% with a NAR average of  $94.1 \pm 0.9\%$ .

In order to improve the system capability in achieving partial nitrification for wastewater with higher nitrogen content, the NLR was further increased to 0.96, 1.08, and 1.2 kg/ (m<sup>3</sup>.d), respectively. Similar behavior was observed during these 3

NLR levels, a drop in ARE efficiency followed by a recovery in performance till a 100% ammonia oxidation while maintaining a stable nitrite accumulation. The overall ARE and NAR achieved during these 3 levels were 98 % and 94 %, respectively.

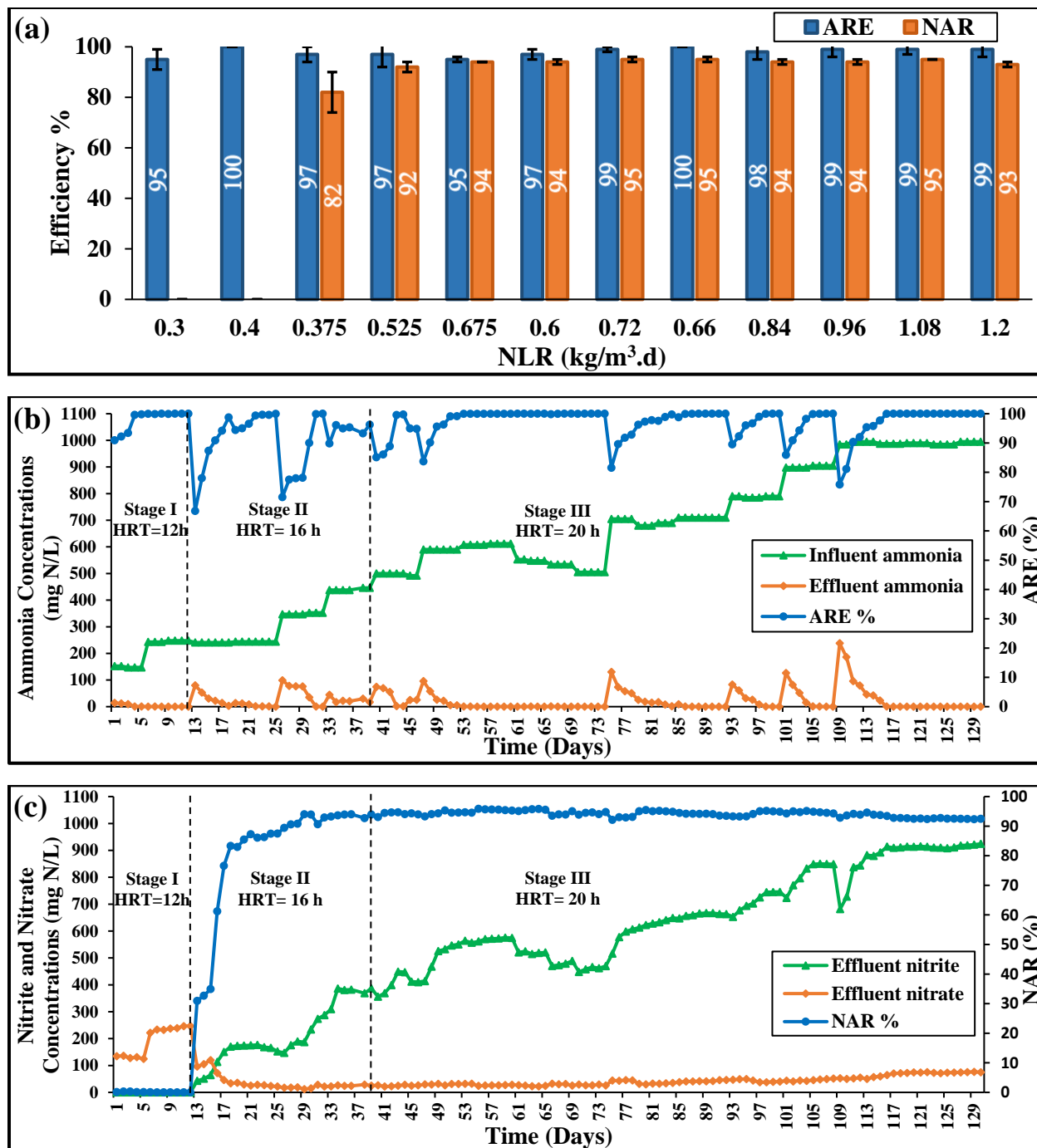

**Figure 3-2: SBR Nitrogen removal performance during the three stages of operation: (a) Ammonia Removal Efficiency (ARE) and Nitrite Accumulation rate (NAR) during different NLR; (b) Influent and Effluent NH<sub>3</sub>-N concentrations and ammonia removal efficiency; (c) NO<sub>2</sub>-N and NO<sub>3</sub>-N concentrations in the effluent and NAR (%)**

### **3.3.2 Factors affecting SBR partial nitrification performance**

#### **3.3.2.1 Effect of DO**

Controlling the dissolved oxygen concentration in the reactor is a key parameter for enhancing the nitrite accumulation and inhibiting its further oxidation to nitrate. It is based on the differences between the Monod saturation constant of oxygen for AOB and NOB that are known to be 0.3 and 1.1 mg/L, respectively [48]. Thus, low DO concentration might be more restrictive for the growth of NOB than AOB due to the higher affinity for oxygen of AOB. This was clearly illustrated in the report of Hanaki et al. (1990) where low DO concentration (0.5 mg/L) produced no effect on ammonia oxidation, while nitrite oxidation was strongly inhibited [73]. Limited DO conditions, however, might cause sludge filamentous bulking problems and result in a low nitrification rate.

As discussed previously, the DO concentration had a significant effect on partial nitrification in the SBR. In stage I, when the DO was controlled at 3.5 mg/L, all the ammonia was oxidized to nitrate with almost no nitrite accumulation in the effluent, which was similar to the results obtained in the literature at the high DO supply. It was reported that the complete nitrification was obtained at a DO concentration of 1.5-2.5 mg/L with almost unobvious nitrite accumulation in a six tanks activated sludge process treating domestic wastewater [76]. Moreover in a SBR treating synthetic wastewater, the initial NAR was decreased from 95.4% to

3.09% under a DO concentration of 2.0-4.0 mg/L, whereas the ARE reached 97.5% [10].

In stage II, when the DO concentration stepped down to 0.5-0.8 mg/L, the nitrite started to build up and NAR increased to 25.6%, whereas the nitrate production decreased in the effluent from 100% to 74.4% during the first day of operation. As the experiment progressed at the same DO level, the nitrate production was considerably restricted to insignificant amount, while nitrite accumulated to reach 93.9% by the end of this stage implying the faster growth rate of AOB than NOB at low DO range as reported in the literature [125]. On the other hand, the limitation of oxygen resulted in a decrease in the ARE from 100% to 65.4% after the first day of operation, which then increased progressively to reach 98.7% after the following 6 days. Similarly, decreasing the DO concentration from the range of 2.0-4.0 to 0.8 mg/L at HRT of 16 h on a SBR treating synthetic wastewater resulted in an increase in NAR from 32.6% to 93.7% as well as a decrease in the ARE from around 95% to 75.4%, which then improved as the experiment progressed to 93.1% [10].

In stage III, the DO limitation was sustained but with a slight increase (0.6-1.2 mg/L) along with a stepwise increase in NLR (0.6-1.2 Kg/ (m<sup>3</sup>.d)) as described previously. This stage was started at NLR of 0.6 Kg/ (m<sup>3</sup>.d) and a DO concentration of 0.6-1.2 mg/L, a successful and complete ammonia removal was achieved after 5

days of operation with a NAR average of  $94.2 \pm 0.5\%$ . Afterwards and in order to have further analysis for this DO increase effects, DO was stepped down back to 0.5-0.8 mg/L, which resulted in an increase in the effluent ammonia concentrations from 1.3 mg  $\text{NH}_3\text{-N/L}$  to 24.8 and 25.4 mg  $\text{NH}_3\text{-N/L}$  in the subsequent 2 days implying that higher DO concentrations was needed to maintain successful complete nitrification during high NLR. In the following days, NLR was increased to 0.72 kg/ $(\text{m}^3\cdot\text{d})$  and DO concentrations stepped up back to 0.6-1.2 mg/L. Hence, full partial nitrification was recovered after 7 days of operation and remained stable for the following week.

### **3.3.2.2 Effect of pH and alkalinity**

Most of the literature suggests that pH in the range of 7.5-8.5 is most suited to inhibit NOB. It has been reported that the optimal pH for Nitrosomonas species ranges between 7.9 and 8.2, while for Nitrobacter species it ranges between 7.2 and 7.6 [22]. Furthermore, pH of 8.0 was reported to be the optimal pH for nitrite accumulation in batch reactors [126], as well pH of 7.5-7.8 was reported to favor simultaneous partial nitrification in free water surface wetlands for dairy wastewater treatment under low DO oxygen concentrations [127]. Partial nitrification leads to the destruction of alkalinity due to the production of  $\text{H}^+$  protons and by consequence lower the pH which may stop the reaction if went lower than 6.5 [128]. Thus, supplying the reactor with sufficient concentration of alkalinity is an important

control parameter for maintaining the pH at the required range to stimulate the nitrite accumulation.

As shown in **Figure 3-3a**, Stage I was initiated at influent alkalinity and ammonia concentration of 1070 mg CaCO<sub>3</sub>/L and 150 mg NH<sub>3</sub>-N/L, respectively. During the first 3 days of operation, negligible concentrations of residual alkalinity were detected in the effluent (below 25 mg CaCO<sub>3</sub>/L) which resulted in a decline in the pH inside the reactor to 5.6-5.9 implying the insufficiency of alkalinity concentrations in the feed. Therefore, alkalinity concentration in the feed was increased to 1730 mg CaCO<sub>3</sub>/L resulting in an increase in pH to 7.8 with average residual alkalinity in the effluent of 400 mg CaCO<sub>3</sub>/L, as well as an enhancement in ARE from 93% to 100%. The previous results could be referred to the consumption of all the alkalinity during ammonia oxidation subsequently further oxidation lowered the pH below 6.5 which resulted in the cut-off of ammonia removal. On the other hand, increasing the alkalinity concentrations in the feed supplied the reaction with sufficient alkalinity to oxidize all the influent ammonia without causing any destruction to the pH values. Afterward, the feed ammonia concentration was increased to 250 mg N/L and correspondingly the feed alkalinity was stepped up to 2730 mg CaCO<sub>3</sub>/L which kept the pH at  $8.4 \pm 0.1$  slightly higher than the required pH with high residual alkalinity concentration in the effluent of  $912.0 \pm 49.3$  mg CaCO<sub>3</sub>/L implying that feed alkalinity was higher than needed.

Hence in Stage II, feed alkalinity was reduced to 2330 mg CaCO<sub>3</sub>/L even though the same feed ammonia concentration was introduced to the reactor. Afterward, as the ammonia in the effluent kept decreasing progressively from 80 to 0.1 mg N/L by the end of operation of this NLR a decrease in the residual effluent alkalinity from 1340 to 819 mg CaCO<sub>3</sub>/L was noticed accompanied with a decline in the pH values from 8.4 to 7.8 which is similar to desired values. The previous results emphasize the feasibility of controlling the pH using the feed alkalinity concentrations strategy. In the same manner, feed alkalinity concentration was increased to 3370 mg CaCO<sub>3</sub>/L with the increase in feed ammonia concentration to 350 mg N/L. However, pH rose to 8.1-8.4 and high residual effluent alkalinity concentrations of 1530-1760 mg CaCO<sub>3</sub>/L was observed which most likely attributed to the increase in pH values. Thus, feed alkalinity concentrations was stepped down to 2840 mg CaCO<sub>3</sub>/L which led to stabilization of pH values at 8.0. Same behavior was noted in Stage III, at the beginning of each NLR the pH and residual alkalinity were high values and then with more ammonia being oxidized both decreased keeping the pH around the required range. During the whole stage, pH was controlled through the alkalinity at range of  $7.8 \pm 0.1$  to  $8.1 \pm 0.1$ .

Furthermore, alkalinity is a crucial parameter for controlling the fraction of ammonia converted to nitrite as the oxidation of 1 mole of ammonia requires the consumption of 2 moles of bicarbonate according to the partial nitrification

stoichiometry shown in (Eq. (3.5)). Thus, controlling the ammonia to alkalinity molar ratio at 0.5 should convert all ammonia to nitrite. Moreover, lower molar ratio values might result in a fraction of the ammonia remaining not oxidized which is the case if the objective is to attain a suitable effluent for subsequent Anammox process where ammonia to bicarbonate molar ratio is controlled at 1:1 to convert only half of the ammonia to nitrite.

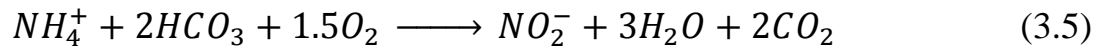

As shown in **Figure 3-3b**, around (0.4-0.6) mole nitrogen was oxidized per 1 mole of alkalinity by the partial nitrification during the whole process which is equivalent to the theoretical molar ratio.

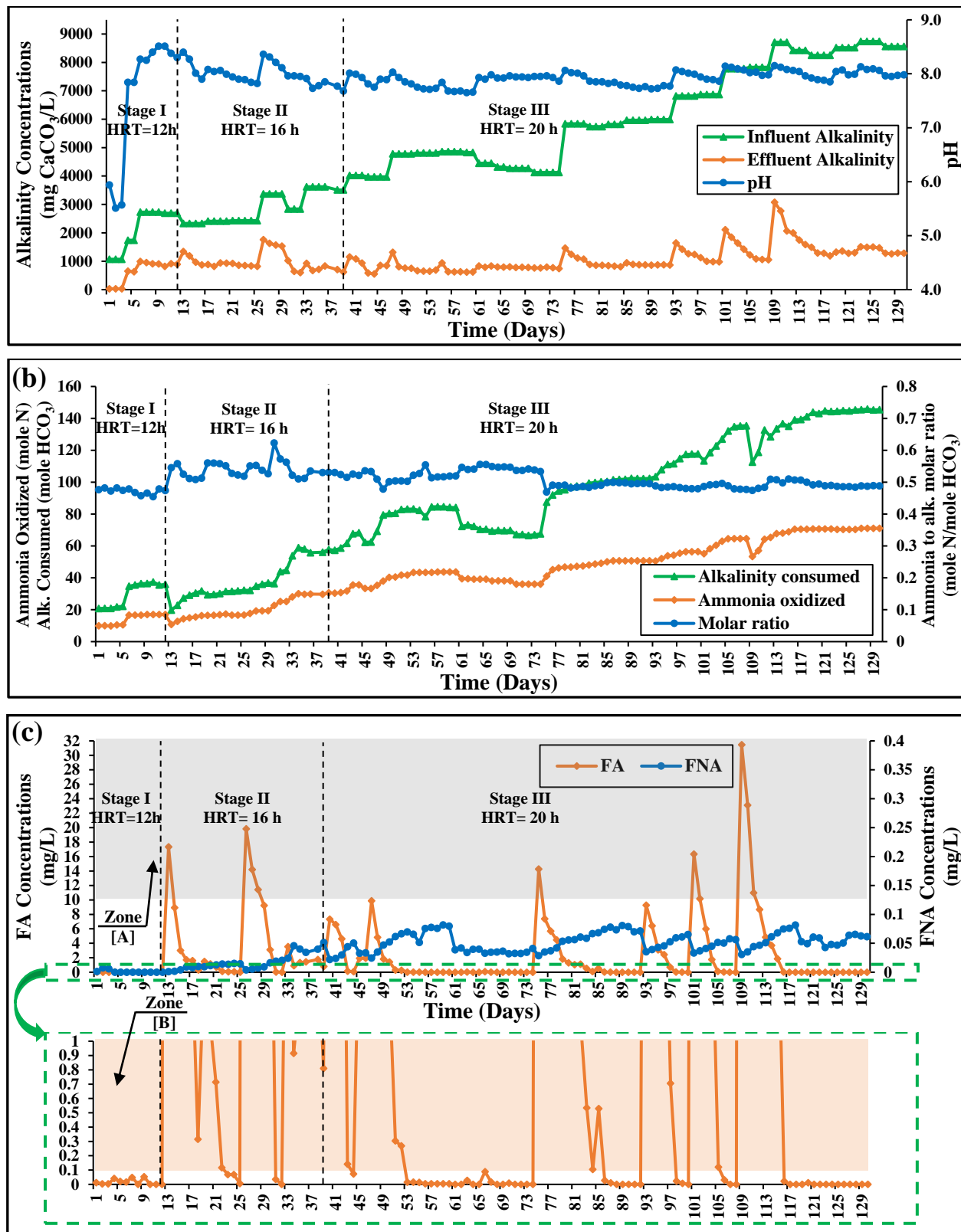

**Figure 3-3: Typical profile for: (a) influent alkalinity concentrations, effluent alkalinity concentrations and pH, (b) oxidized ammonia to alkalinity consumed molar ratio, and (c) free ammonia (FA) and free nitrous acid (FNA) concentrations where Zone [A]: FA inhibition to AOB and Zone [B]: FA inhibition to NOB**

### 3.3.2.3 Effect of free ammonia (FA) and free nitrous acid (FNA)

Other than having a direct influence on partial nitrification, pH values affects the equilibrium of free ammonia (FA) and free nitrous acid (FNA) which appear to have an inhibitory effect on both AOB and NOB differently. However, the nitrite oxidizers are more sensitive to FA as a concentration of 0.1-1.0 mg/L was reported to inhibit its activity compared to 10-150 mg/L for AOB [116].

As shown in **Figure 3-3c**, the FA concentrations varied during the operation time with the variation of pH and ammonia concentration. In stage I, FA concentration was  $0.02 \pm 0.02$  mg/L below the reported values for both AOB and NOB inhibition allowing complete nitrification to occur. Afterward decreasing the DO concentrations in stage II resulted in an increase in FA concentration after the first day operation to 17.33 mg/L which was among the reported inhibition limit for ammonia and nitrite oxidizers explaining the drop in ARE. As the experiment progressed, FA concentrations decreased gradually within the range of 0.12 to 8.93 inhibiting the NOB activity which resulted in nitrite accumulation. Moreover, each increase of NLR was accompanied with an increase in FA concentration resulting in a short inhibition for both nitrifying bacteria consequently a drop in ammonia oxidation. However, this increase does not last for a long period of operation as an instantaneous drop in FA concentration was noted to the limit of NOB inhibition

only stabilizing at this range till NLR was stepped up allowing nitrite to build up inside the reactor.

On the other hand, FNA had a slighter but a still present effect on suppressing NOB and accumulating nitrite in the reactor. According to Zhou et al. (2011) studies, a range of 0.011-0.07 mg/L FNA starts to inhibit NOB while complete inhibition occurs at a range of 0.026-0.22 mg/L whereas AOB inhibition occurs at a range of 0.42-1.72 mg/L, thus FNA concentrations of around 0.02-0.03 mg/L has been suggested suitable to washout NOB and stimulate AOB growth [117].

In stage I, the FNA concentrations was 0.003 mg/L lower than the reported inhibitions values for both AOB and NOB, thus conventional ammonia oxidation to nitrate was achieved. Moreover in stage II at NLR of 0.375 and 0.525, the FNA inhibition was insignificant as FNA concentrations remained relatively low inside the reactor. However at NLR of 0.675, the increase in nitrite concentration in the reactor as well as the relatively lower pH were accompanied with an increase in FNA concentrations to 0.042 mg/L among the inhibition values for NOB inhibition improving the NAR to  $93.6 \pm 0.5\%$ . Furthermore, in stage III the FNA concentrations was higher reaching at some days of operations 0.082 mg/L improving the NAR at these days to 96%. Overall during the partial nitrification phase, FNA was among the reported values for NOB washout in short cut nitrification reactors.

### 3.3.2.4 The fate of nitrogen

During the operation period, nitrogen loss was noted through the nitrogen mass balance. The aforementioned fate in nitrogen may be caused by several factors proposed in the literature including the increased pH, the DO limitation, and the abundance of nitrite [129]. Since pH affects the equilibrium between the ionized and unionized forms of ammonium, increasing pH increases the proportion of FA over the ionized  $\text{NH}_4^+$  which easily diffuses from liquid to gaseous phase during aeration contributing in the fate of nitrogen inside the reactor. Moreover under DO limitation and nitrite abundance, a portion of the nitrogen oxidized might be converted to nitrous oxide  $\text{N}_2\text{O}$  through: (i) the reduction of nitrite produced through enzymes nitrite reductase (Nir) and nitric oxide reductase (Nor) in low DO concentration, (ii) denitrification in anoxic zones inside the reactor, and (iii) oxidation of hydroxylamine produced from ammonia oxidation [130].

During the first 3 days of operation, the average nitrogen loss ratio was 4.05%. However, a significant increase in nitrogen loss ratio to 10.6% was observed afterward which may be attributed to the increase in the pH from 5.7 to 7.8. Afterward, at the beginning of each new NLR level the nitrogen fate was noted to be very high reaching 20% at some levels due to the corresponding high FA concentrations, however with the decrease in FA concentrations in the latter days

the nitrogen loss was noted to decrease correspondingly. During the 130 days of operation, the average nitrogen loss was 4.52 %.

### **3.3.3 PCR identification**

As shown in **Figure 3-4** (lane 2-6), sample 1 did not give any PCR product with any of the used primers indicating that AOBs were not washed out from the system during the decanting phase. For Sample 2 (lane 7-11), it showed required PCR with AmoA-1F and AmoA-2R (491bp), CTO189fA/B and CTO 654R (465 bp), Primer 3F and Primer 2R (193 bp), and NSR 1113F and NSR 1264 (151 bp) indicating the presence of AOB bacteria as well as Nitrospira species of NOB in the biomass whereas it did not show any PCR products with FGPS872 and FGPS1269 primer set revealing that the biomass has negligible or no amount of Nitrobacter species of NOB. It was noteworthy that the quantity of PCR products were different likely due to a difference in population sizes of the target strains.

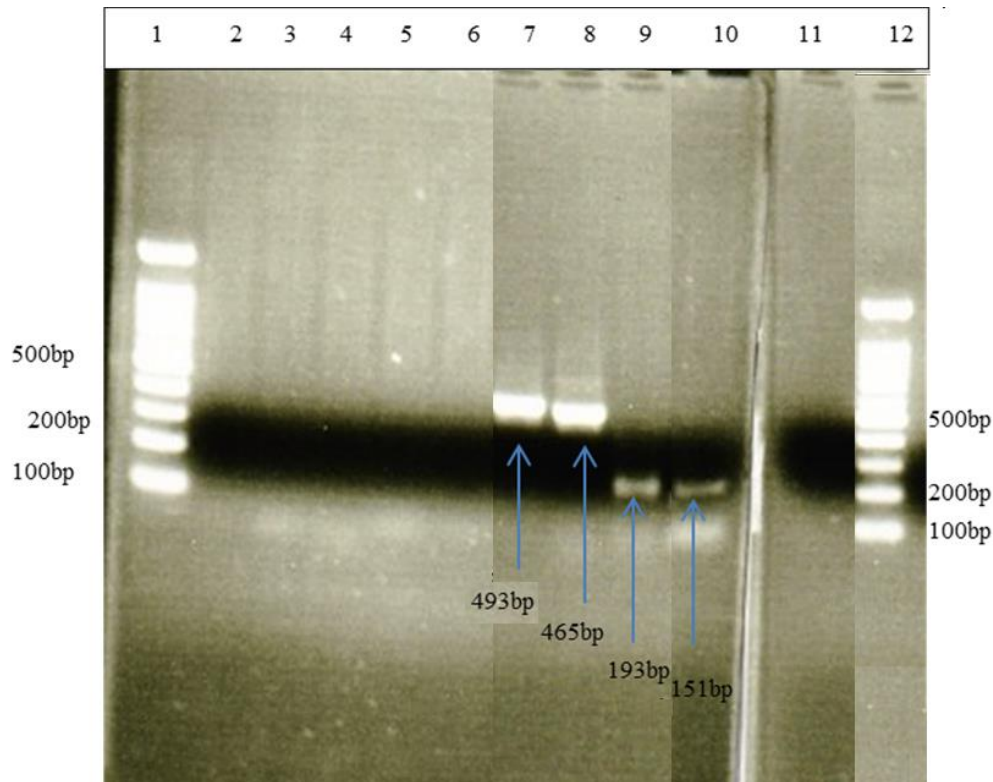

**Figure 3-4: PCR products using genomic DNA of sample 1 and 2 with the five sets of primers.**

*Lane 1 and 12 contains 100 bp DNA ladder. Lane 2-6 contains PCR products of sample 1 where lane 2 contains PCR products from primers AmoA-1F and AmoA-2R; lane 3 contains PCR products from primers CTO189fA/B and CTO 654R; lane 4 contains PCR products from primers 3F and Primer 2R; lane 5 contains PCR products from primers NSR 1113F and NSR 1264; lane 6 contains PCR products from primers FGPS872 and FGPS1269. Lane 7-11 contains PCR products of sample 2 where lane 7 contains PCR products from primers AmoA-1F and AmoA-2R; lane 8 contains PCR products from primers CTO189fA/B and CTO 654R; lane 9 contains PCR products from primers 3F and Primer 2R; lane 10 contains PCR products from primers NSR 1113F and NSR 1264; lane 11 contains PCR products from primers FGPS872 and FGPS1269.*

### 3.4. Conclusions

The feasibility of using the novel DO control strategy has been demonstrated for achieving stable complete partial nitrification. After 130 days of operation, the NLR reached 1.2 kg/ (m<sup>3</sup>.day) maintaining an ARE of  $98.6 \pm 2.8\%$  with NAR of  $93.0 \pm 0.7\%$ , which is 2 times higher than the previous NLR reported in the literature. The combination of DO limitations conditions, high temperature (31 °C), high pH (7.8-8.1), feeding strategy (stepwise increase in ammonia concentrations), and sufficient alkalinity concentrations as well as FA and FNA inhibitions contributed in halting the ammonia oxidation step at the nitrite stage and by consequence reaching a high NAR.

# CHAPTER 4

## LONG-TERM DYNAMIC AND PSEUDO-STATE MODELING OF COMPLETE PARTIAL NITRIFICATION PROCESS AT HIGH NITROGEN LOADING RATES IN A SBR\*

### 4.1 Introduction

Partial nitrification encounters some rigorous challenge associated with maintaining long term stable nitrite build-up as nitrification is rate limiting step and NOB grows twice faster than AOB in the absence of limitation conditions, thus NOB inhibition is required for attaining partial nitrification [131]. Several inhibitions strategies have been included in the literature including (i) DO limitations conditions, (ii) free ammonia (FA) and free nitrous acid (FNA) inhibition, (iii) Temperature control and (iv) pH control [3]–[5], [116]. Therefore, partial nitrification has been performed with several reactors configurations whether in suspended growth systems such as continuous stirred tanks reactors (CSTR), sequential batch reactors (SBR) and single reactor for high activity ammonia removal over nitrite (SHARON) or attached growth systems such as Membrane bioreactor (MBR), Moving Bed Biofilm (MBBR) reactors and Biofilm Airlift Suspension (BAS) [6]–[11].

Moreover, SBRs have shown great success in achieving nitrite accumulation at high nitrogen loading rates due to its discontinuous feeding which allows the reactor to maintain high ammonia concentration as well as the sequencing of the feeding phase would help to control possible FA and FNA accumulations inside the reactor and by consequence inhibiting NOB. In a SBR operated with a stepwise increase in influent ammonium concentration, an ammonia removal efficiency (ARE) of  $98.6 \pm 2.8\%$  with NAR of  $93.0 \pm 0.7\%$  was achieved at a nitrogen loading rate (NLR) of  $1.2 \text{ kg/ (m}^3\cdot\text{day)}$  through a novel DO control strategy depending on the mixing regime [132]. The combination of DO limitations conditions, high temperature ( $31 \text{ }^\circ\text{C}$ ), high pH (7.8-8.1), feeding strategy, and sufficient alkalinity concentrations as well as FA and FNA inhibitions contributed in reaching a high nitrite accumulation at high NLR.

An important step to facilitate the scale-up of partial nitrification SBR systems at high NLR is the development of a process model at dynamic and pseudo-state and perform process calibration and validation. Several models have been used for partial nitrification process design in SBRs and have been tested experimentally in lab and pilot scale. Wett and Rauch, (2003) developed and calibrated a SBR model to optimize and investigate the inorganic carbon limitation effect on a nitrification-denitrification for rejection-water and landfill leachate using the data of two full-scale rejection water treatment plants [131]. The model results proved that bicarbonate

concentrations have a significant effect on the process performance and its optimization could enhance the nitrification rate up to 100 mg NH<sub>4</sub>-N/ (L.h.). Moreover, Xavier et al., (2007) developed and calibrated a model simulating the data of an aerobic granular sludge SBR for integrated removal of COD, nitrogen to describe the dynamics of nutrient removal [133]. The model results suggested that nitrogen removal was achieved mainly by alternating nitrification/denitrification rather than simultaneous nitrification/denitrification. Pambrun et al. (2006) proposed a mathematical model to optimize partial nitrification in SBR, however the model was validated to confirm its predicting capability using one-cycle duration only. Thus, the proposed model described only the short-term dynamics of nitrogenous compounds and it was stated that long-term dynamics should be the purpose of future works [59]. Moreover, Jones et al. (2007) calibrated a model using BioWin to evaluate the design conditions and operating strategies for a sidestream treatment process pilot plant using a SBR operated in a nitrification-denitrification mode, likewise the simulation of different parameters (pH, DO) and predicted nitrogenous compounds were run for only one day (3 cycles) [51]. Furthermore, a model was developed and calibrated to fit the main physical-chemical measurements of a partial nitrification SBR (PN-SBR) treating raw urban landfill leachate [134]. The model was validated by predicting the behavior of the nitrogen compounds, inorganic carbon and pH using one cycle data. Hence, most studies on SBR modeling were

evaluated considering only the short time dynamics (cycle based dynamics model) by simulating the reactor behavior during specific SBR cycles.

Moreover, the success of these models is defined only by their ability to predict the dynamic behavior of the experimental SBR used for simulation, thus a precedent calibration step might be needed for the model to accurately fit the experimental data obtained. Calibration is a complex process and can vary from a modeler to another which makes comparing the model's results challenging. Hence, Petersen et al., (2002) and few others proposed a systematical guideline protocol to keep the calibration consistent and organized, such as BIOMATH, HSG, WERF, and STOWA [12], [13], [14], and [15], respectively. However, the suggested protocols focus on the continuous flow systems, thus an adapted methodology for SBR calibration was proposed [135]. The main challenge encountering SBR calibration is developing the pseudo-steady state model required for the calibration as the variables in a SBR keep changing with time and no real steady state can be reached. However, a pseudo-stable state model might be considered in the case of SBR calibration instead of the steady state model. The pseudo-state occurs when the final characteristics at the end of one cycle are similar to those of the following cycle. The proposed calibration of the modified SBR protocol comprises three steps: (i) developing a pseudo-stable state simulation with average flows and concentrations until the long term parameters are adjusted, (ii) developing a daily dynamic state

where dynamic flows and concentrations are considered for a couple of days to obtain proper initial conditions for the following step, and (iii) performing a cycle dynamic state simulation to finalize the adjustment of parameters. However, the selection of the parameters to be calibrated is a time and effort intensive process in case all the parameters were not measured during the experiment. Thus, identifying the most sensitive parameters before the calibration is a very efficient tool to achieve a quick and adequate model calibration.

Therefore, up until now, all previous comprehensive literature review demonstrates that no models are readily available that can accurately predict the long-term dynamic behavior of partial nitrification SBRs as well all proposed calibration protocols require a respirometric analysis for the model calibration step.

Thus, the objective of this chapter is to develop a BioWin model to describe the long-term dynamic behavior of a lab-scale SBR performing complete partial nitrification as a first step of nitrite shunt process at different nitrogen loading rates (NLR). Moreover, introduce a new step (i.e. identifiability analysis step) in the calibration protocols to eliminate the needs of the respirometric analysis for SBR models and rank all kinetic and stoichiometric parameters according to their significant effect on rapid shifting from complete nitrification to partial nitrification.

## 4.2 Materials and Methods

### 4.2.1 Experimental SBR

The experiment was conducted in a 2L lab-scale SBR performing partial nitrification through DO limitation conditions controlled by mixing regime. The SBR was operated, controlled and monitored using a control device (BioFlo<sup>®</sup> 115 Benchtop Fermenter & Bioreactor, New Brunswick, USA) connected to a heating jacket and a mechanical mixer for control process as well as a DO probe and a thermometer for monitoring as shown in **Figure 3-1a**.

The SBR was operated for 130 days with a constant cycle of 4 hours of total duration. The reactor was fed with synthetic solution devoid of any organic substrate with a stepwise increase of ammonium concentration in order to reach a maximum nitrogen loading rate (NLR) without having an inhibitory effect on the biomass due to a sudden shock load. The reactor temperature was kept at 31°C and pH was controlled through the alkalinity concentration in the feed to maintain it in the range of 7.9-8.2. The reactor was operated in three stages with different operations conditions as illustrated in **Table 3-2a**. During stage I (days 1 to 13), complete nitrification was attained through controlling the DO concentrations at high concentrations (up to 3.5 mg/L). At the beginning of Stage II ( days 13 to 39) , DO limitation conditions was induced to the reactor through decreasing the DO

concentrations inside the reactor to (0.5-0.8 mg/L) to suppress nitrite oxidizing bacteria (NOB) and stimulate the growth of ammonia oxidizing bacteria (AOB) and by consequence achieving partial nitrification. Whereas stage III (days 40 to 130) aimed to reach higher NLR and DO was slightly increased to (0.6-1.2 mg/L) to correspond the higher aeration requirement of higher ammonia concentrations. Further reactor design and operations details can be found in Section 3.2.

#### **4.2.2 SBR Model**

The experimental results of the SBR were modeled and calibrated using BioWin<sup>®</sup> (4.1) software developed by Envirosim Associates Ltd. (Burlington, ON, Canada). The SBR was modeled using basic reactors available in BioWin<sup>®</sup>, i.e. influent, single-tank SBR, effluent, and sludge wastage as shown in **Figure 4-1**. Moreover, nitrous oxide modelling was included to model the potential nitrous oxide generation by autotrophs under low dissolved concentrations and excess free nitrous acid conditions.

The model influent fractions, simulated using the influent specifier associated with BioWin<sup>®</sup>, was modified to correspond the feed characteristics of the experimental SBR. The ammonia fraction ( $F_{na}$ ), particulate organic nitrogen fraction ( $F_{nox}$ ), and soluble unbiodegradable TKN fraction ( $F_{nus}$ ) were modified to 1.0 g NH<sub>3</sub>-N/g TKN, 0 g N/g organic N, and 0 g N/g TKN, respectively, as the SBR feed was

synthetic solution containing only ammonia. Similarly, the phosphate fraction ( $F_{p04}$ ) was modified to 1.0 g  $PO_4$ -P/g TP.

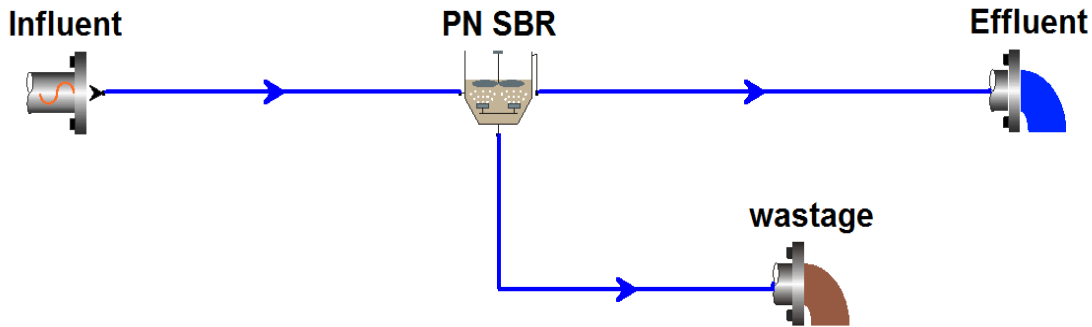

*Figure 4-1: BioWin<sup>®</sup> schematic diagram of SBR model*

### 4.2.3 SBR calibration protocol

All the previously mentioned protocols share almost a similar structure starting from defining the calibration objectives followed by collecting and analyzing the data, afterwards a steady state calibration is developed followed by a dynamic one and lastly the results are evaluated but with each protocol having its particular perspective of each step. The SBR calibration used in this study followed both BIOMATH and the adapted SBR protocols with minor modifications to suit the specific conditions of the partial nitrification system as well as the model objective as described in the following sections.

#### **4.2.3.1 Stage I: Defining the objectives**

In both protocols the first stage consists of defining the goals of the study, which according to it, the following steps might be defined. The objective of this study is simulating the experimental data of a SBR performing partial nitrification and obtaining a model able to describe the dynamic behavior of the SBR for a better understanding of the kinetics parameters stimulating the fast shift from complete nitrification to partial nitrification.

#### **4.2.3.2 Stage II: Data collection**

This stage aims to specify the plant layout, operational conditions, and the measured data which is the most crucial data in this stage [12]. The plant layout consists of the determination of the reactor volume/area/depth, water and sludge lines, pumps, diffusers while the operational conditions includes the process hydraulic retention time (HRT), temperature, pH, DO set points, cycle duration and seed characteristics. Since this model simulates an existing experimental SBR, the plant layout and operational conditions were previously provided as described in Section 4.2.1. Moreover, influent ammonia, alkalinity, pH as well as effluent ammonia, nitrate, nitrite, alkalinity, pH were measured daily. Furthermore DO, pH, and temperature inside the reactor were provided through probes located inside the reactor and connected to the control device.

#### **4.2.3.3 Stage III: Data analysis**

In this stage data evaluation and mass balance are carried out for a better understanding of the plant behavior and identifying any potential error. In this study, means and standard deviations for the effluent data were calculated and compared to the literature data. Mass balances of nitrogen compounds were conducted and factors affecting the SBR performance were evaluated proving that all the experimental data are reliable.

#### **4.2.3.4 Stage IV: Model Calibration**

In this stage, the model implemented in BioWin<sup>®</sup> software is used to fit the experimental data. However, using the default ASM values provided by the software did not lead to results similar to those obtained in the experimental SBR especially the immediate nitrite-build up and decrease in the nitrate production observed in the experimental SBR after decreasing the DO concentrations to (0.5-0.8 mg/L) at the beginning of Stage II.

Hence in order to meet the experimental SBR effluent criteria, the model needed to be calibrated through adjusting the kinetics and stoichiometry parameters. However due to lack of a respirometric analysis, the actual kinetics and stoichiometric parameters of the experimental SBR biomass were not available, thus an identifiability analysis step was carried out precedent to the model calibration in order to determine an identifiable subset of parameters to

calibrate the models. Hence, this stage can be divided into two main steps: (i) identifiability analysis and (ii) model calibration.

#### 4.2.3.4.1 Identifiability analysis

In order to identify a suitable subset of parameters to calibrate the model, 14 individual kinetic and stoichiometric parameter for AOB and NOB have been evaluated as well as 3 different outputs (effluent ammonia, nitrate, and nitrite) using the normalized sensitivity coefficient ( $S_{i,j}$ ) and the mean square sensitivity measure ( $\delta_j^{msqr}$ ). The normalized sensitivity coefficient ( $S_{i,j}$ ) is defined as the ratio of percentage change in the output values ( $Y_i$ ) to the change in the input values ( $X_j$ ) as shown in Eq. (4.1) and is used to assess the impact of the change in the input parameters on the output parameters while the mean square sensitivity measure ( $\delta_j^{msqr}$ ) shown in Eq. (4.2) is used to rank the parameters according to their significance effect on the outputs [136].

$$S_{i,j} = \frac{|\Delta Y_i/Y_i|}{|\Delta X_j/X_j|} \quad (4.1)$$

$$\delta_j^{msqr} = \sqrt{\frac{1}{n} \sum_{i=1}^n S_{i,j}^2} \quad (4.2)$$

Following the adapted SBR protocol proposed by [135], the identifiability analysis has been based on the pseudo-stable state profiles of the first phase in Stage II to simulate the fast shift from complete nitrification to partial nitrification that occurred

in the experimental SBR which could not be simulated using the default kinetics and stoichiometric values. The pseudo-stable state for the partial nitrification SBR had an average influent ammonia and alkalinity concentrations of  $242.6 \pm 1.5$  mg NH<sub>3</sub>-N/L and  $2393.1 \pm 42.9$  mg CaCO<sub>3</sub>/L, respectively.

#### **4.2.3.4.2 Calibration**

The model was calibrated using the pseudo-stable state influent and effluent data by manually modifying the kinetic and stoichiometric parameters of AOB and NOB previously found to have the most significant influence on partial nitrification in the identifiability analysis until the model data fits the experimental data.

#### **4.2.3.5 Model validation and data evaluation**

After calibrating the model, it was validated using a long-term dynamic model simulating the 130 days of operation including the daily dynamic influent data for the three stages and the results were compared to those obtained from the experimental SBR to assess the quality of the fits. The main parameters considered in the comparison were the effluent ammonia, nitrate, nitrite, alkalinity and pH.

## 4.3 Results and discussions

### 4.3.1 Identifiability analysis

In order to determine the identifiability of the kinetics and stoichiometric parameters in shifting from complete nitrification to partial nitrification conditions, 14 kinetic and stoichiometric parameters of AOB and NOB were subjected to a change of  $\pm 50\%$  of their default values in BioWin<sup>®</sup> and corresponding normalized sensitivity coefficient ( $S_{i,j}$ ) were calculated with regard to 3 effluent characteristics: ammonia (NH<sub>3</sub>-N), nitrate (NO<sub>3</sub>-N) and nitrite (NO<sub>2</sub>-N) as illustrated in **Table 4-1**.

**Table 4-1: Normalized sensitivity coefficient ( $S_{i,j}$ ) of effluent characteristics of kinetic and stoichiometric parameters**

Parameter	Symbol	Unit	Normalized sensitivity coefficient ( $S_{i,j}$ )		
			NH <sub>3</sub> -N	NO <sub>3</sub> -N	NO <sub>2</sub> -N
<b>Ammonia Oxidizing Bacteria (AOB)</b>					
Maximum specific growth rate	$\mu_{\max, \text{AOB}}$	(1/d)	2.0	0.8	15.2
Substrate (NH <sub>4</sub> ) half saturation	$K_{\text{NH}_4}$	(mg N/L)	1.3	0.9	17.8
Aerobic decay rate	$b_{\text{AOB}}$	(1/d)	0.7	0.4	7.3
Anoxic/Anaerobic decay rate	$b_{\text{anaerobic, AOB}}$	(1/d)	0.7	0.4	7.7
Nitrous acid inhibition concentration	$K_{\text{iHNO}_2}$	(mmol/L)	0.0	0.9	1.9
DO half saturation	$K_{\text{o, AOB}}$	(mg O <sub>2</sub> /L)	1.3	0.4	7.4
Yield	$Y_{\text{AOB}}$	(mg COD/mg N)	1.3	0.9	16.8
<b>Nitrite Oxidizing Bacteria (NOB)</b>					
Maximum specific growth rate	$\mu_{\max, \text{NOB}}$	(1/d)	0.7	1.6	32.4
Substrate (NO <sub>2</sub> ) half saturation	$K_{\text{NO}_2}$	(mg N/L)	0.0	0.1	0.2
Aerobic decay rate	$b_{\text{NOB}}$	(1/d)	0.7	0.5	10.4
Anoxic/Anaerobic decay rate	$b_{\text{anaerobic, NOB}}$	(1/d)	0.7	0.7	13.5
Ammonia inhibition concentration	$K_{\text{iNH}_3}$	(mmol/L)	0.7	0.1	2.0
DO half saturation	$K_{\text{o, NOB}}$	(mg O <sub>2</sub> /L)	0.7	0.7	13.3
Yield	$Y_{\text{NOB}}$	(mg COD/mg N)	0.7	0.9	17.3

It is noteworthy that  $S_{i,j}$  for nitrite ( $\text{NO}_3\text{-N}$ ) accounted for the highest values indicating the high variation in effluent nitrite concentrations with the change in the input parameters which may be referred to the nitrite buildup following the DO limitations conditions induced to the reactor in the beginning of the pseudo-stable state model used in the identifiability analysis

Moreover, the mean square sensitivity measure ( $\delta_j^{msqr}$ ) was calculated for each parameter taking into account the normalized sensitivity coefficient for the 3 effluent parameters. All parameters were ranked according to their  $\delta_j^{msqr}$  values with the most sensitive parameters ranked first as shown in **Table 4-2**.

**Table 4-2: Mean square sensitivity measure ( $\delta_j^{msqr}$ ) ranking of kinetic and stoichiometric parameters**

Rank	Parameter	Symbol	Unit	$\delta_j^{msqr}$
1	NOB Maximum specific growth rate	$\mu_{\max, \text{NOB}}$	(1/d)	18.7
2	AOB Substrate ( $\text{NH}_4$ ) half saturation	$K_{\text{NH}_4}$	(mg N/L)	10.3
3	NOB Yield	$Y_{\text{NOB}}$	(mg COD/mg N)	10.0
4	AOB Yield	$Y_{\text{AOB}}$	(mg COD/mg N)	9.8
5	AOB Maximum specific growth rate	$\mu_{\max, \text{AOB}}$	(1/d)	8.9
6	NOB Anoxic/Anaerobic decay rate	$b_{\text{anaerobic, NOB}}$	(1/d)	7.8
7	NOB DO half saturation	$K_{\text{o, NOB}}$	(mg $\text{O}_2$ /L)	7.7
8	NOB Aerobic decay rate	$b_{\text{NOB}}$	(1/d)	6.0
9	AOB Aerobic decay rate	$b_{\text{AOB}}$	(1/d)	4.6
10	AOB Anoxic/Anaerobic decay rate	$b_{\text{anaerobic, AOB}}$	(1/d)	4.5
11	AOB DO half saturation	$K_{\text{o, AOB}}$	(mg $\text{O}_2$ /L)	4.4
12	NOB Ammonia inhibition concentration	$K_{\text{iNH}_3}$	(mmol/L)	1.2
13	AOB Nitrous acid inhibition concentration	$K_{\text{iHNO}_2}$	(mmol/L)	1.1
14	NOB Substrate ( $\text{NO}_2$ ) half saturation	$K_{\text{NO}_2}$	(mg N/L)	0.1

NOB Maximum specific growth rate ( $\mu_{\max, \text{NOB}}$ ) had the highest influence on nitrite accumulation and nitrate suppression and by consequence achieving rapid partial nitrification. Decreasing AOB Substrate ( $\text{NH}_4$ ) half saturation ( $K_{\text{NH}_4}$ ) accounted for high nitrite build up as well followed by the yield for both NOB and AOB. Moreover, it is noteworthy that increasing or decreasing NOB Substrate ( $\text{NO}_2$ ) half saturation ( $K_{\text{NO}_2}$ ) did not affect the partial nitrification SBR performance significantly as well as AOB Nitrous acid inhibition concentration ( $K_{\text{iHNO}_2}$ ) and NOB Ammonia inhibition concentration ( $K_{\text{iNH}_3}$ ).

### **4.3.2 Model Calibration**

Model calibration is the identification of the model parameters values that need to be changed in order to make the model able to fit the obtained experimental data which the model was not able to predict using the default parameters values. In this study, performing the simulation with default parameters led to a significant variation between model and experimental effluent data mainly in terms of nitrate and nitrite concentrations. A slow nitrite accumulation and nitrate suppression were observed and partial nitrification with high nitrite accumulation rate ( $\text{NAR} > 85\%$ ) could not be reached before 40 days compared to 7 days in the experimental SBR indicating the slow shift from complete nitrification to partial nitrification when the default parameter were used, hence calibration of the kinetic and stoichiometric parameter was essential. The model calibration was based on trial and error by

manually tuning the parameters following their reported range in the literature and comparing the pseudo-stable state data of the model and the measured ones. The tuned parameters were selected according to their rank in the identifiability analysis starting with the most sensitive parameters having the highest rank. However, one of the kinetic parameters - NOB yield - which was ranked 3<sup>rd</sup> was not modified since no higher values than its default value was reported in the literature [28], [48], [51], [59], [70]. As a result, the 5 most sensitive kinetics parameters, i.e. NOB and AOB maximum specific growth rate, AOB substrate half saturation, NOB anoxic/anaerobic decay rate, and NOB DO half saturation as well as 1 stoichiometric parameter, i.e. AOB yield were modified within the range reported in the literature as illustrated in **Table 4-3**.

The results of the pseudo-stable state simulation with the default values showed that although the DO concentrations were decreased to start the inhibition of NOBs, almost complete nitrification was still occurring in the reactor as the nitrite accumulation rate (NAR) was lower than 5% against 82.5% in the experimental SBR in the same period of time.

**Table 4-3: Comparison between the default, literature and calibrated values for the selected kinetics and stoichiometric parameters used in BioWin®**

Parameter	Symbol	Unit	Default value	Literature range	Calibrated value	Calibrated Value Reference
NOB Maximum specific growth rate	$\mu_{\max, \text{NOB}}$	(1/d)	0.7	0.16 – 2.6	<b>0.48</b>	[70]
AOB Substrate ( $\text{NH}_4$ ) half saturation	$K_{\text{NH}_4}$	(mg N/L)	0.7	0.14 – 1.35	<b>0.5</b>	[59]
AOB Yield	$Y_{\text{AOB}}$	(mg COD/mg N)	0.15	0.11 - 0.39	<b>0.147</b>	[48]
AOB Maximum specific growth rate	$\mu_{\max, \text{AOB}}$	(1/d)	0.9	0.24 – 1.96	<b>1.08</b>	[28]
NOB Anoxic/Anaerobic decay rate	$b_{\text{anaerobic, NOB}}$	(1/d)	0.08	0.04 – 0.17	<b>0.1</b>	[137]
NOB DO half saturation	$K_{\text{o, NOB}}$	(mg $\text{O}_2$ /L)	0.5	0.43 – 1.75	<b>1.1</b>	[48]

On the other hand, running the pseudo-stable state simulation with the calibrated value resulted in successful nitrate suppression and nitrite build up and the nitrite accumulation rate (NAR) reached 83% implying the successful shift from complete nitrification to partial nitrification as shown in **Table 4-4**. However, it was noteworthy that ammonia removal efficiency (ARE) was almost 100% in both the calibrated and the default model which was slightly higher than the obtained ARE in the experiment of 96.8%. The previous discrepancy in the results may be referred to the slight inhibition of AOB activity occurring in the beginning of each phase in the experimental SBR resulting from the high free ammonia (FA) concentrations accompanying the increase in ammonia concentrations that was reported to inhibit AOB at a range of 10-150 mg/L which could not be imported to the model [116].

**Table 4-4: Comparison between pseudo-stable-state influent and effluent characteristics of the experimental SBR, SBR model after calibration and SBR model before calibration**

Parameter	Influent		Effluent		
	Experimental	Model	Experimental	Calibrated Model	Default Model
Ammonia (mg NH <sub>3</sub> -N/L)	242.6 ± 1.5	243.0	7.7 ± 7.1	0.1 ± 0.1	0.1 ± 0.1
Alkalinity (mg CaCO <sub>3</sub> /L)	2393.1 ± 42.9	2400.0	881.5 ± 42.34	826.2 ± 1.5	744.3 ± 1.0
Nitrate (mg NO <sub>3</sub> -N/L)	-	-	<b>34.4 ± 14.2</b>	<b>33.7 ± 9.5</b>	<b>211.1 ± 1.3</b>
Nitrite (mg NO <sub>2</sub> -N/L)	-	-	<b>162.0 ± 18.3</b>	<b>163.8 ± 9.2</b>	<b>9.7 ± 1.0</b>
pH	-	-	8.0 ± 0.2	8.1 ± 0.0	7.9 ± 0.0

### 4.3.3 Model validation and data evaluation

The model was validated using the daily dynamic data of the experimental SBR which consisted of three main stages as described earlier. In each stage the nitrogen loading rate (NLR) was increased gradually by increasing the feeding ammonia concentrations to prevent any shock effect on the biomass that could result from high ammonia concentrations. Stage I consisted of 2 phases with NLR of 0.3 and 0.4 mg NH<sub>3</sub>/L and aimed to perform complete nitrification. Stage II comprised three phases with different NLR and the model was calibrated using the data of the first phase of this stage where partial nitrification conditions were introduced to the reactor by decreasing the DO concentration to the range of (0.5-0.8) mg/L. Whereas Stage III included 7 phases and aimed to reach partial nitrification at high NLR, thus DO concentration was increased to 0.6-1.2 mg/L to support the higher oxygen demand of high ammonia concentrations in the influent.

**Table 4-5** summarizes the main results obtained at each phase in the experimental and model SBR. In stage I, almost all the influent ammonia was oxidized to nitrate with almost no nitrite accumulation in the effluent in both phases except for the first 3 days in phase I where insufficient feed alkalinity led to a fraction of the ammonia not being oxidized. As apparent in **Table 4-5**, the model accurately predicted the effluent data for phase I with an average percentage error (APE) for ammonia, nitrate, alkalinity and pH of 2.74, 5.35, 1.58 and 1.54 %, respectively. Similarly, complete ammonia conversion to nitrate was successfully predicted by the model with an APE of 2.8, 4.5 and 2.38 % for effluent nitrate, alkalinity and pH respectively. The previous results imply that complete nitrification was successfully modeled and a close match between the experimental and predicted results was reached.

In stage II, inhibition conditions was induced to the reactor in the beginning of the first phase ( $NLR = 0.375 \text{ kg}/(\text{m}^3 \cdot \text{day})$ ) and by consequence nitrite started to build up inside the reactor. The average effluent concentrations in this phase was  $162.0 \pm 18.3 \text{ mg NO}_2\text{-N/L}$  in the experiment against  $164.9 \pm 11.9 \text{ NO}_2\text{-N/L}$  corresponding to an APE of 1.79%. Moreover, nitrate, alkalinity and pH results were closely matched between the experiment and model with an APE of 11.34, 6.23 and 1.25 %, respectively. However, a discrepancy in ammonia results was observed between the experiment and the model where all the ammonia was oxidized due to

the previously mentioned inhibition of AOB by FA concentrations accompanying the increase of NLR at the beginning of the phase. Likewise, similar results were obtained in the next two phases with suitable fit between the experimental and predicted values revealing the success of the calibrated model to simulate the rapid shift from complete nitrification to partial nitrification.

In stage III, feed ammonia concentrations was further increased to reach higher NLRs and 7 phases were included. During these phase a variation in the effluent nitrate concentrations was observed between the model where the nitrate concentration kept decreasing until no nitrate was produced during the last two phases indicating the complete inhibition of NOBs and the experimental data where the nitrate production remained stable at a range of 5-7 % of the influent ammonia. The aforementioned discrepancy as shown in *Figure 4-2d* might be referred to the reported NOB adaptation to inhibition conditions after a period of time which enables it to recover slowly its activity [138]–[140]. However, effluent nitrite concentrations were closely matched between the experimental and model data with a slight increase in the model values resulting from the variation in nitrate concentrations, yet the APE during the 7 phases were 5.36, 3.14, 5.96, 5.18, 4.97, 4.1 and 6.52 %, respectively as shown in *Figure 4-2c*. Moreover, effluent alkalinity concentrations and pH remained accurately predicted by the model as shown in *Figure 4-2a* and *Figure 4-2b*.

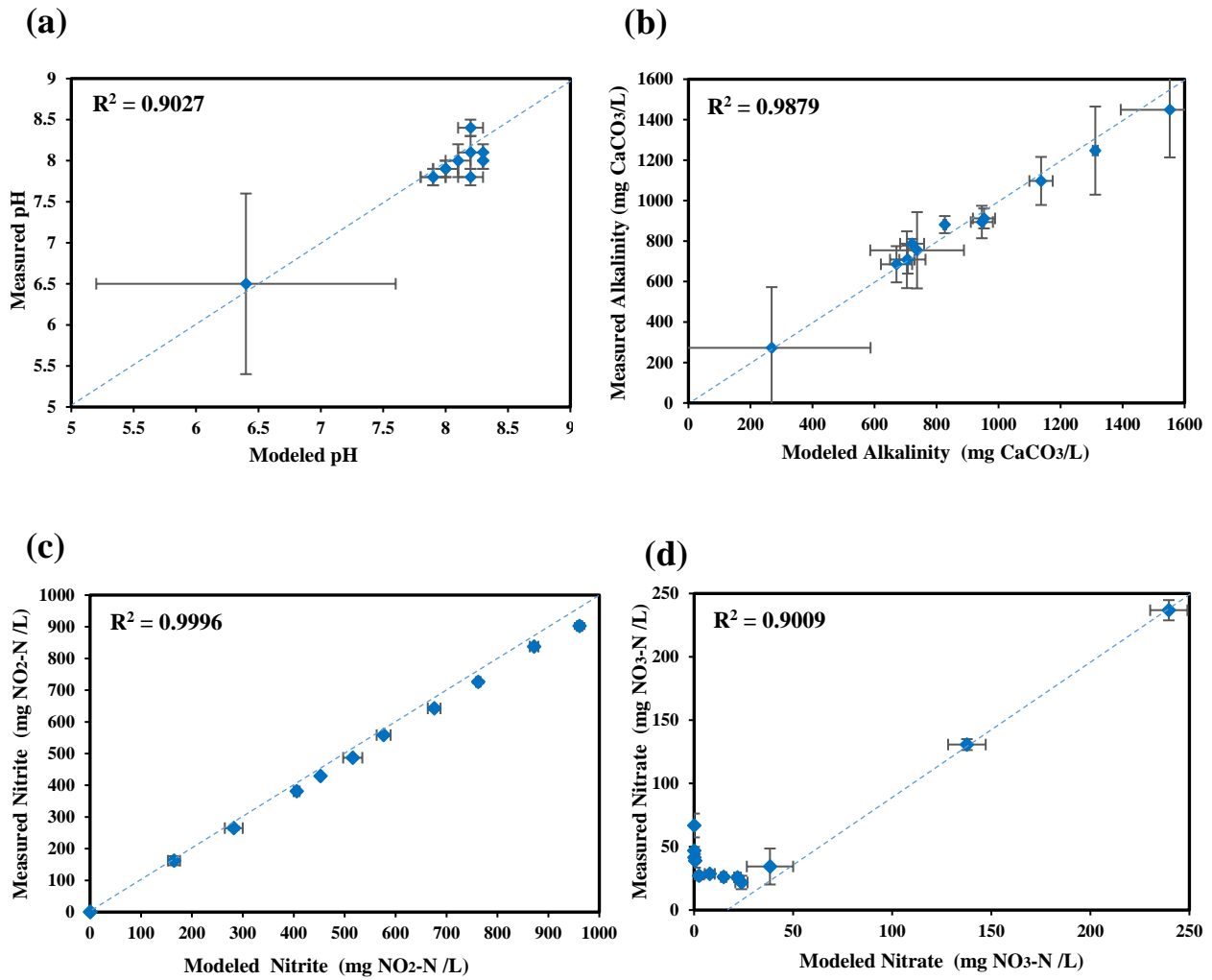
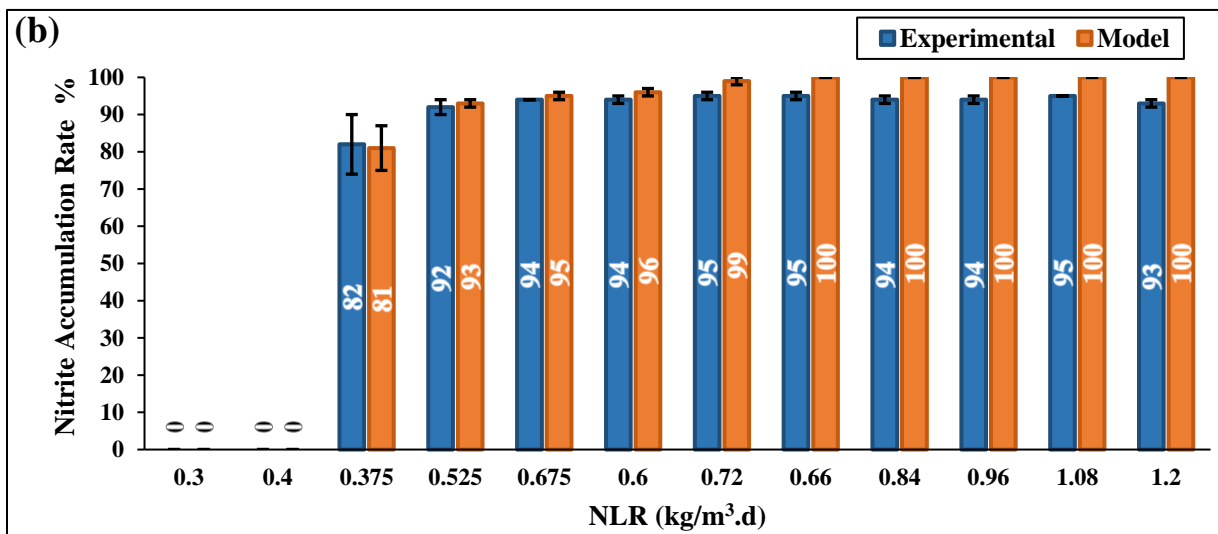
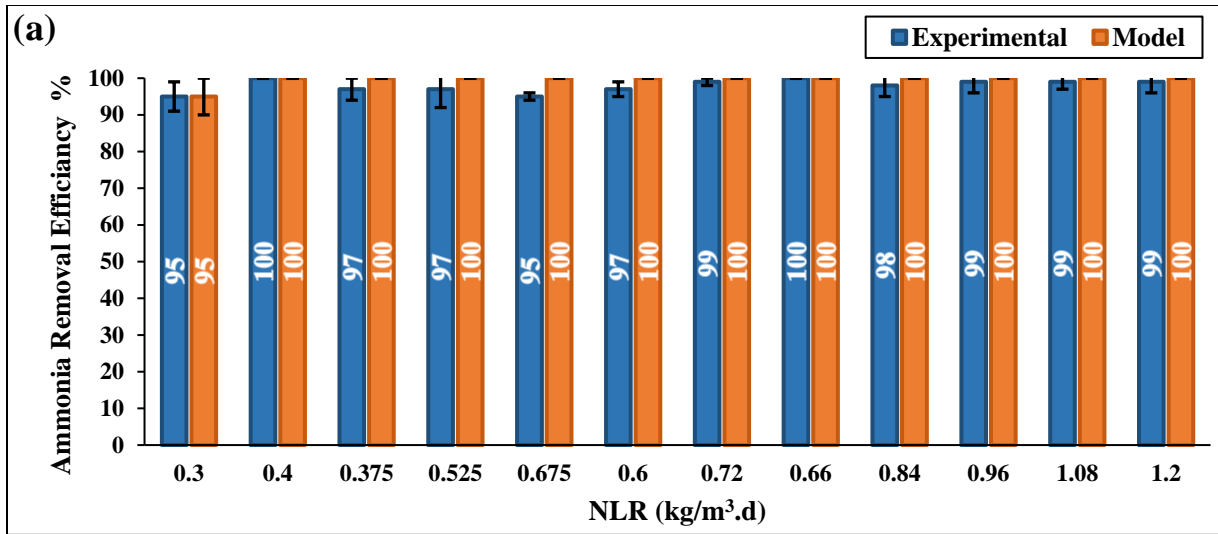

**Figure 4-2: Correlation between model and measured effluent parameters for: (a) pH, (b) alkalinity, (c) nitrite, (d) nitrate (Note: vertical and horizontal error bars represent the standard deviations for the measured and model results, respectively)**

**Table 4-5: Comparison between the average effluent data obtained in the experimental SBR and predicted by the model during the different operational stages**

Stage	NLR (Kg/(m <sup>3</sup> . d))	Effluent									
		Experimental					Model				
		Ammonia (mg N/L)	Nitrite (mg N/L)	Nitrate (mg N/L)	Alkalinity (mg CaCO <sub>3</sub> /L)	pH	Ammonia (mg N/L)	Nitrite (mg N/L)	Nitrate (mg N/L)	Alkalinity (mg CaCO <sub>3</sub> /L)	pH
<b>I</b>	0.3	7.3 ± 5.7	0.24 ± 0.1	130.7 ± 4.3	272.8 ± 299.9	6.5 ± 1.1	7.1 ± 9.9	0.20 ± 0.3	137.7 ± 9.5	268.5 ± 318.8	6.4 ± 1.2
	0.4	0.1 ± 0.1	0.04 ± 0.1	236.8 ± 8.0	912.0 ± 49.3	8.4 ± 0.1	0.1 ± 0.0	0.05 ± 0.0	239.6 ± 9.4	953.1 ± 35.6	8.2 ± 0.1
<b>II</b>	0.375	7.7 ± 7.1	162.0 ± 18.3	34.4 ± 14.2	881.5 ± 42.3	8.0 ± 0.2	0.1 ± 0.1	164.9 ± 11.9	38.3 ± 11.7	826.6 ± 4.1	8.1 ± 0.1
	0.525	11.9 ± 16.5	264.9 ± 22.6	21.8 ± 5.3	754.7 ± 188.5	8.1 ± 0.2	0.0	282.2 ± 17.6	23.9 ± 3.1	737.3 ± 251.1	8.2 ± 0.1
	0.675	21.3 ± 4.8	381.0 ± 6.5	25.8 ± 1.7	708.6 ± 69.3	7.8 ± 0.1	0.0	405.6 ± 5.9	21.9 ± 1.7	707.3 ± 57.2	7.9 ± 0.1
<b>III</b>	0.6	13.4 ± 11.7	429.5 ± 18.5	26.1 ± 1.3	708.0 ± 140.5	7.9 ± 0.1	0.0	452.5 ± 2.5	14.9 ± 1.4	704.5 ± 24.3	8.0 ± 0.1
	0.72	5.0 ± 8.7	558.4 ± 16.0	28.6 ± 2.7	685.6 ± 89.5	7.8 ± 0.1	0.0	576.5 ± 13.7	7.9 ± 2.5	671.0 ± 50.4	7.9 ± 0.1
	0.66	0.11 ± 0.26	486.8 ± 26.4	27.1 ± 2.9	787.3 ± 23.5	7.9 ± 0.1	0.0	515.8 ± 18.8	2.4 ± 0.9	721.3 ± 38.6	8.0 ± 0.1
	0.84	12.7 ± 17.6	642.4 ± 22.3	38.9 ± 5.4	894.4 ± 80.2	7.8 ± 0.1	0.0	675.7 ± 12.5	0.5 ± 0.3	946.2 ± 35.7	8.2 ± 0.1
	0.96	11.0 ± 12.9	726.1 ± 21.2	41.5 ± 4.3	1097.3 ± 118.7	8.0 ± 0.1	0.0	762.2 ± 4.5	0.1 ± 0.1	1137.1 ± 37.7	8.3 ± 0.0
	1.08	11.4 ± 18.7	837.6 ± 19.3	46.9 ± 3.0	1247.3 ± 217.8	8.1 ± 0.1	0.0	871.9 ± 8.3	0.0	1312.0 ± 8.2	8.3 ± 0.0
	1.2	14.3 ± 28.1	902.4 ± 23.5	66.8 ± 9.4	1449.2 ± 235.9	8.0 ± 0.1	0.0	961.2 ± 5.3	0.0	1552.3 ± 158.2	8.3 ± 0.0

Moreover, the ammonia removal efficiency (ARE) and the nitrite accumulation rate (NAR) were calculated for each phase for the experiment and the model to evaluate the SBR performance. As illustrated in *Figure 4-3*, complete nitrification was achieved during the first 2 NLRs (Stage I) with ARE of 95% and 100% at NLR of 0.3 and 0.4 Kg/ (m<sup>3</sup>.d) respectively in both experiment and model with no nitrite accumulation. In stage II, nitrite started to build up inside the reactor reaching NAR of 82, 92 and 94 % in the experiment effluent and 81, 93 and 95% in the model effluent at NLR of 0.375, 0.525 and 0.675 Kg/ (m<sup>3</sup>.d) respectively. In stage III, NAR in the experimental SBR was in the range of 93-95 % during the different phases against 100% in the SBR model due to the previously mentioned NOB adaptation. On the other hand, almost complete ammonia removal was achieved in stage II and III in both experimental and model SBR with an ARE of 95-99% and 100% respectively, this slight difference is referred to the free ammonia inhibition limitations stated earlier.



**Figure 4-3: Comparison between experimental and model data during different Nitrogen loading levels (NLR) in terms of: (a) Ammonia removal efficiency (ARE), (b) Nitrite accumulation rate (NAR)**

Moreover, daily effluent nitrite, nitrate concentrations and pH measured in the experiment and predicted by the dynamic model were illustrated in **Figure 4-4**. It can be observed in **Figure 4-4a** and **Figure 4-4b** that ammonia oxidation followed the same pattern in both experimental and model SBR with a slight decrease in nitrite concentrations in the experimental values after a period time due to the further oxidation of small portion of the produced nitrite to nitrate resulting from NOB adaptation and slowly recovery of its activity. Moreover, pH values as well were closely matched except for a variation occurring in the first couple of days at each phase of the experimental SBR where a portion of the ammonia was not oxidized due to high FA concentrations resulting in a decrease in the alkalinity concentration and by consequence an increase in the pH as shown in **Figure 4-4c**.

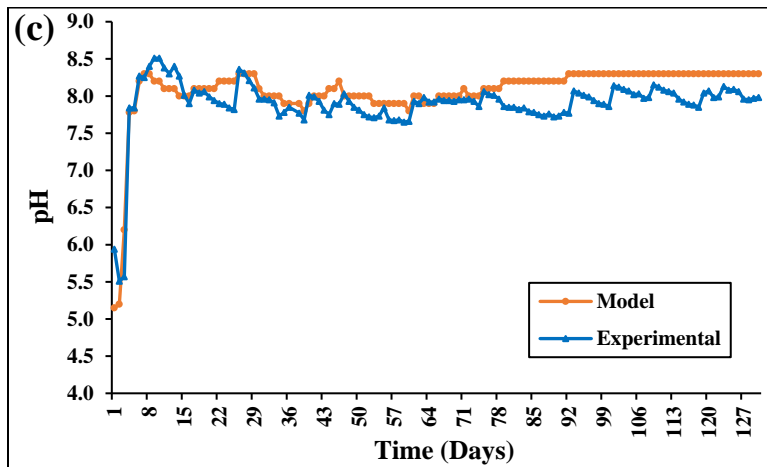
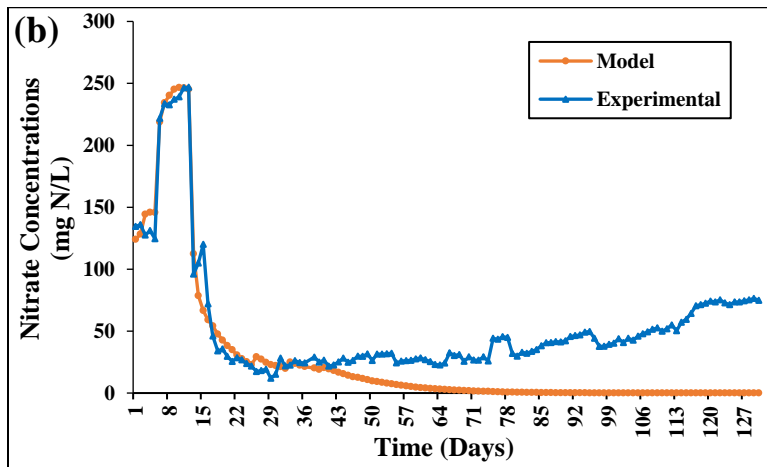
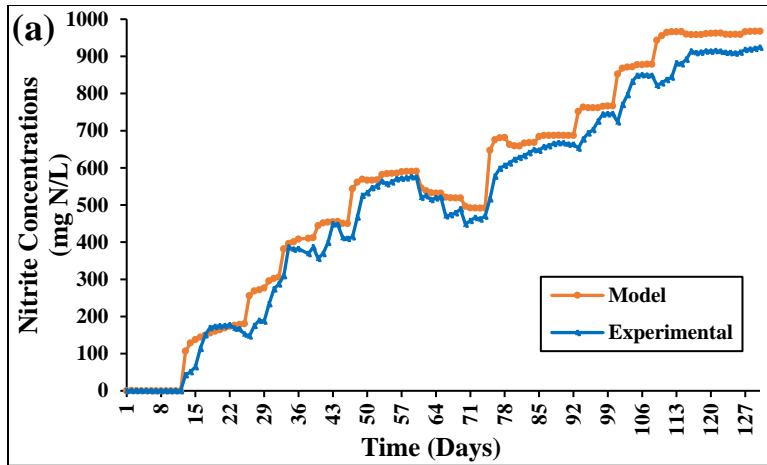

**Figure 4-4: Comparison between daily effluent measured and dynamic model data for: (a) Nitrite concentrations; (b) nitrate concentrations; (c) pH**

## 4.4 Conclusions

A long-term dynamic model of partial nitrification has been developed and calibrated using BioWin software to fit the data obtained from a lab scale SBR. The calibrated model was able to predict accurately the daily effluent ammonia, nitrate, nitrite, alkalinity concentrations and pH during all different operational conditions. Moreover, the calibrated model was able to simulate the rapid shift from complete nitrification to partial nitrification after modifying the values of 5 kinetics parameters, i.e. NOB and AOB maximum specific growth rate, AOB substrate half saturation, NOB anoxic/anaerobic decay rate, and NOB DO half saturation as well as 1 stoichiometric parameter, i.e. AOB yield identified as the most influential parameters on partial nitrification through an identifiability analysis. 14 individual kinetic and stoichiometric parameter for AOB and NOB have been evaluated as well as 3 different outputs (effluent ammonia, nitrate, and nitrite) using the normalized sensitivity coefficient ( $S_{i,j}$ ) and the mean square sensitivity measure ( $\delta_j^{msqr}$ ) to rank the parameters according to their significant effect on shifting to partial nitrification. The dynamic model results confirmed the feasibility of achieving complete partial nitrification as a first step of nitrite shunt process through the combination of DO limitations conditions, high temperature (31 °C), high pH, feeding strategy (stepwise increase in ammonia concentrations), and sufficient alkalinity concentrations.

# CHAPTER 5

## CONCLUSIONS AND FUTURE WORK

This chapter summarizes the major findings of this thesis along with the direction of future work

### 5.1 Conclusions

The main objective of this thesis is to develop a robust, efficient and sustainable system for achieving complete partial nitrification as the first step of the Nitrite shunt process at high NLR to increase the capability of WWTPs in treating higher ammonia content. The main findings were as follows:

- Stable partial nitrification can be achieved in a suspended growth system using SBR process at a NLR up to 1.2 kg/ (m<sup>3</sup>.day) maintaining an ARE of  $98.6 \pm 2.8\%$  with NAR of  $93.0 \pm 0.7\%$ .
- The DO limitation conditions was an efficient control strategy for inhibiting NOB and by consequence stimulating AOB to outcompete NOB towards achieving high nitrite accumulation.
- The developed DO control strategy using variable mixing regime has been proved to be a feasible strategy towards better control for DO concentrations and preventing biomass settling

- Adjusting the alkalinity concentrations in the feed is a feasible strategy to control the pH inside the reactors within the required range for favoring AOB growth
- FA and FNA played an important role in inhibiting NOB activity. FA and FNA concentrations in the range of 0.3-1.5 mg FA/L and 0.02-0.07 mg FNA/L have been suitable for NOB inhibition without having an inhibitory effect of AOB.
- The development of a long-term dynamic and pseudo-state model is an important step for a better understanding of the experimental reactor dynamic behavior as well as the biomass kinetics and stoichiometric parameters.
- Performing an identifiability analysis step precedent to the model calibration is crucial for determining the most sensitive parameters that need to be calibrated for the model to accurately fit the experimental data obtained and by consequence eliminating the need of a prior respirometric analysis.
- NOB and AOB maximum specific growth rate, AOB substrate half saturation, NOB anoxic/anaerobic decay rate, NOB DO half saturation, AOB and NOB yield have been identified to be the most influential kinetic and stoichiometric parameters that led to the rapid shift from complete to partial nitrification through the identifiability analysis.

- Following a systematical guideline calibration protocol such as BIOMATH, HSG, WERF, and STOWA is important in order to keep the calibration consistent and organized.
- The dynamic developed model results confirmed the feasibility of achieving complete partial nitrification as a first step of nitrite shunt process through the combination of DO limitations conditions, high temperature (31 °C), high pH, feeding strategy (stepwise increase in ammonia concentrations), and sufficient alkalinity concentrations.

## **5.2 Direction of Future work**

Considering the potential of the partial nitrification and nitrite shunt process, several research points can be suggested for future work to further enhance the nitrogen removal process and reduce the energy need of WWTPs and apply different biological processes to the AOBs:

- Performing partial nitrification in an attached growth system using a biofilm process to increase the capability of WWTPs in receiving higher NLR.
- Developing a system to achieve both partial nitrification and subsequent denitritation and phosphorus removal processes in the same reactor.

- Study the applicability of performing denitrification process using autotrophic bacteria subsequent to partial nitrification to eliminate the need of external carbon addition towards a more economical process for nitrogen removal from wastewater
- Determine the applicability of developing a bio-based system to produce biofuels using AOB capability of oxidizing methane ( $\text{CH}_4$ ) to methanol ( $\text{CH}_3\text{OH}$ ) via the nonspecific action of the membrane bound ammonia monooxygenase (AMO).

## BIBLIOGRAPHY

- [1] Y. Peng and G. Zhu, “Biological nitrogen removal with nitrification and denitrification via nitrite pathway,” *Appl. Microbiol. Biotechnol.*, vol. 73, no. 1, pp. 15–26, Oct. 2006.
- [2] S. P. Klapwijk and Stichting Toegepast Onderzoek Waterbeheer, *25 jaar toegepast onderzoek waterbeheer: jubileumsymposium STOWA 13 september 1996*. Utrecht; Zoetermeer: STOWA ; Hageman Verpakkers [distr.], 1996.
- [3] S. Fudala-Ksiazek, A. Luczkiewicz, K. Fitobor, and K. Olanczuk-Neyman, “Nitrogen removal via the nitrite pathway during wastewater co-treatment with ammonia-rich landfill leachates in a sequencing batch reactor,” *Environ. Sci. Pollut. Res.*, vol. 21, no. 12, pp. 7307–7318, Jun. 2014.
- [4] J. Gabarró, R. Ganigué, F. Gich, M. Rusalleda, M. D. Balaguer, and J. Colprim, “Effect of temperature on AOB activity of a partial nitrification SBR treating landfill leachate with extremely high nitrogen concentration,” *Bioresour. Technol.*, vol. 126, pp. 283–289, Dec. 2012.
- [5] R. Ganigué, H. López, M. Rusalleda, M. D. Balaguer, and J. Colprim, “Operational strategy for a partial nitrification–sequencing batch reactor treating urban landfill leachate to achieve a stable influent for an anammox reactor,” *J. Chem. Technol. Biotechnol.*, vol. 83, no. 3, pp. 365–371, Mar. 2008.
- [6] J. Choi and Y. Ahn, “Comparative performance of air-lift partial nitrification processes with attached growth and suspended growth without biomass retention,” *Environ. Technol.*, vol. 35, no. 11, pp. 1328–1337, Jun. 2014.
- [7] U. Daalkhaijav and M. Nemati, “Ammonia loading rate: an effective variable to control partial nitrification and generate the anaerobic ammonium oxidation influent,” *Environ. Technol.*, vol. 35, no. 5, pp. 523–531, Mar. 2014.
- [8] S. Milia, G. Cappai, M. Perra, and A. Carucci, “Biological treatment of nitrogen-rich refinery wastewater by partial nitrification (SHARON) process,” *Environ. Technol.*, vol. 33, no. 13, pp. 1477–1483, Jul. 2012.
- [9] L. Shen, Y. Yao, and F. Meng, “Reactor performance and microbial ecology of a nitrification membrane bioreactor,” *J. Membr. Sci.*, vol. 462, pp. 139–146, Jul. 2014.
- [10] D. Wei, B. Du, X. Xue, P. Dai, and J. Zhang, “Analysis of factors affecting the performance of partial nitrification in a sequencing batch reactor,” *Appl. Microbiol. Biotechnol.*, vol. 98, no. 4, pp. 1863–1870, Feb. 2014.
- [11] A. Zafarzadeh, B. Bina, H. M. Attar, and M. H. Nejad, “Performance of moving bed biofilm reactors for biological nitrogen compounds removal from

- wastewater by partial nitrification-denitrification process,” *Iran. J. Environ. Health Sci. Eng.*, vol. 7, no. 4, pp. 353–364, 2010.
- [12] P. A. Vanrolleghem *et al.*, “A comprehensive model calibration procedure for activated sludge models,” *ResearchGate*, vol. 2003, no. 9, Jan. 2003.
- [13] G. Langergraber *et al.*, “A guideline for simulation studies of wastewater treatment plants,” *ResearchGate*, vol. 50, no. 7, pp. 131–8, Feb. 2004.
- [14] B. Petersen, K. Gernaey, M. Henze, and P. A. Vanrolleghem, “Evaluation of an ASM 1 model calibration procedure on a municipal-industrial wastewater treatment plant,” *ResearchGate*, vol. 4, no. 1, Jan. 2002.
- [15] J. J. W. Hulsbeek, J. Kruit, P. J. Roeleveld, and M. C. M. van Loosdrecht, “A practical protocol for dynamic modelling of activated sludge systems,” *ResearchGate*, vol. 45, no. 6, pp. 127–36, Feb. 2002.
- [16] C. j.-P. Boonaert, C. c. Dupont-Gillain, P. b. Dengis, Y. f. Dufrêne, and P. g. Rouxhet, “Cell Separation, Flocculation,” in *Encyclopedia of Bioprocess Technology*, John Wiley & Sons, Inc., 2002.
- [17] C. Nicoletta, M. C. M. van Loosdrecht, and J. J. Heijnen, “ChemInform Abstract: Wastewater Treatment with Particulate Biofilm Reactors,” *ChemInform*, vol. 31, no. 36, p. no-no, Jun. 2010.
- [18] H.-P. Koops and A. Pommerening-Röser, “Distribution and ecophysiology of the nitrifying bacteria emphasizing cultured species,” *FEMS Microbiol. Ecol.*, vol. 37, no. 1, pp. 1–9, 2001.
- [19] U. Purkhold, A. Pommerening-Röser, S. Juretschko, M. C. Schmid, H.-P. Koops, and M. Wagner, “Phylogeny of all recognized species of ammonia oxidizers based on comparative 16S rRNA and amoA sequence analysis: implications for molecular diversity surveys,” *Appl. Environ. Microbiol.*, vol. 66, no. 12, pp. 5368–5382, 2000.
- [20] J. Geets, N. Boon, and W. Verstraete, “Strategies of aerobic ammonia-oxidizing bacteria for coping with nutrient and oxygen fluctuations: Strategies of AOB for coping with nutrient and oxygen fluctuations,” *FEMS Microbiol. Ecol.*, vol. 58, no. 1, pp. 1–13, Oct. 2006.
- [21] G. A. Kowalchuk and J. R. Stephen, “Ammonia-oxidizing bacteria: a model for molecular microbial ecology,” *Annu. Rev. Microbiol.*, vol. 55, no. 1, pp. 485–529, 2001.
- [22] B. Sinha and A. P. Annachhatre, “Partial nitrification—operational parameters and microorganisms involved,” *Rev. Environ. Sci. Biotechnol.*, vol. 6, no. 4, pp. 285–313, Aug. 2007.
- [23] Y. Aoi *et al.*, “Microbial ecology of nitrifying bacteria in wastewater treatment process examined by fluorescence in situ hybridization,” *J. Biosci. Bioeng.*, vol. 90, no. 3, pp. 234–240, Jan. 2000.

- [24] D. Zhang, D. Zhang, and others, “Community analysis of ammonia oxidizer in the oxygen-limited nitrification stage of OLAND system by DGGE of PCR amplified 16S rDNA fragments and FISH,” *J. Environ. Sci.*, vol. 16, no. 5, pp. 838–842, 2004.
- [25] P. C. Burrell, C. M. Phalen, and T. A. Hovanec, “Identification of Bacteria Responsible for Ammonia Oxidation in Freshwater Aquaria,” *Appl. Environ. Microbiol.*, vol. 67, no. 12, pp. 5791–5800, Dec. 2001.
- [26] K. Otawa *et al.*, “Molecular analysis of ammonia-oxidizing bacteria community in intermittent aeration sequencing batch reactors used for animal wastewater treatment,” *Environ. Microbiol.*, vol. 8, no. 11, pp. 1985–1996, Nov. 2006.
- [27] I. Schmidt *et al.*, “New concepts of microbial treatment processes for the nitrogen removal in wastewater,” *FEMS Microbiol. Rev.*, vol. 27, no. 4, pp. 481–492, Oct. 2003.
- [28] J. H. Ahn, R. Yu, and K. Chandran, “Distinctive microbial ecology and biokinetics of autotrophic ammonia and nitrite oxidation in a partial nitrification bioreactor,” *Biotechnol. Bioeng.*, vol. 100, no. 6, pp. 1078–1087, Aug. 2008.
- [29] S. Logemann, J. Schantl, S. Bijvank, M. van Loosdrecht, J. G. Kuenen, and M. Jetten, “Molecular microbial diversity in a nitrifying reactor system without sludge retention,” *FEMS Microbiol. Ecol.*, vol. 27, no. 3, pp. 239–249, 1998.
- [30] A. K. Rowan, J. R. Snape, D. Fearnside, M. R. Barer, T. P. Curtis, and I. M. Head, “Composition and diversity of ammonia-oxidising bacterial communities in wastewater treatment reactors of different design treating identical wastewater,” *FEMS Microbiol. Ecol.*, vol. 43, no. 2, pp. 195–206, 2003.
- [31] Y. Law, L. Ye, Y. Pan, and Z. Yuan, “Nitrous oxide emissions from wastewater treatment processes,” *Philos. Trans. R. Soc. B Biol. Sci.*, vol. 367, no. 1593, pp. 1265–1277, May 2012.
- [32] I. Suzuki, U. Dular, and S. C. Kwok, “Ammonia or ammonium ion as substrate for oxidation by *Nitrosomonas europaea* cells and extracts,” *J. Bacteriol.*, vol. 120, no. 1, pp. 556–558, 1974.
- [33] B. Sinha and A. P. Annachhatre, “Partial nitrification—operational parameters and microorganisms involved,” *Rev. Environ. Sci. Biotechnol.*, vol. 6, no. 4, pp. 285–313, Aug. 2007.
- [34] D. Arp, L. Sayavedra-Soto, and N. Hommes, “Molecular biology and biochemistry of ammonia oxidation by *Nitrosomonas europaea*,” *Arch. Microbiol.*, vol. 178, no. 4, pp. 250–255, Oct. 2002.

- [35] A. B. Hooper, T. Vannelli, D. J. Bergmann, and D. M. Arciero, "Enzymology of the oxidation of ammonia to nitrite by bacteria," *Antonie Van Leeuwenhoek*, vol. 71, no. 1–2, pp. 59–67, 1997.
- [36] M. Whittaker, D. Bergmann, D. Arciero, and A. B. Hooper, "Electron transfer during the oxidation of ammonia by the chemolithotrophic bacterium *Nitrosomonas europaea*," *Biochim. Biophys. Acta BBA - Bioenerg.*, vol. 1459, no. 2–3, pp. 346–355, Aug. 2000.
- [37] G. Sin *et al.*, "Modelling nitrite in wastewater treatment systems: a discussion of different modelling concepts," *Water Sci. Technol.*, vol. 58, no. 6, p. 1155, Oct. 2008.
- [38] U. Wiesmann, "Biological nitrogen removal from wastewater," *Biotechnics/wastewater*, pp. 113–154, 1994.
- [39] H. Melcer, *Methods for Wastewater Characterization in Activated Sludge Modelling*. IWA Publishing, 2004.
- [40] J.-H. Kim, X. Guo, and H.-S. Park, "Comparison study of the effects of temperature and free ammonia concentration on nitrification and nitrite accumulation," *Process Biochem.*, vol. 43, no. 2, pp. 154–160, Feb. 2008.
- [41] C. Hellinga, A. a. J. C. Schellen, J. W. Mulder, M. C. M. van Loosdrecht, and J. J. Heijnen, "The sharon process: an innovative method for nitrogen removal from ammonium-rich waste water," *Water Sci. Technol.*, vol. 37, no. 9, pp. 135–142, May 1998.
- [42] R. Blackburne, V. M. Vadivelu, Z. Yuan, and J. Keller, "Determination of Growth Rate and Yield of Nitrifying Bacteria by Measuring Carbon Dioxide Uptake Rate," *Water Environ. Res.*, vol. 79, no. 12, pp. 2437–2445, Nov. 2007.
- [43] J. Carrera, I. Jubany, L. Carvallo, R. Chamy, and J. Lafuente, "Kinetic models for nitrification inhibition by ammonium and nitrite in a suspended and an immobilised biomass systems," *Process Biochem.*, vol. 39, no. 9, pp. 1159–1165, May 2004.
- [44] C. Chiellini *et al.*, "Characterization and Comparison of Bacterial Communities Selected in Conventional Activated Sludge and Membrane Bioreactor Pilot Plants: A Focus on Nitrospira and Planctomycetes Bacterial Phyla," *Curr. Microbiol.*, vol. 67, no. 1, pp. 77–90, Jul. 2013.
- [45] I. Jubany, J. Carrera, J. Lafuente, and J. A. Baeza, "Start-up of a nitrification system with automatic control to treat highly concentrated ammonium wastewater: Experimental results and modeling," *Chem. Eng. J.*, vol. 144, no. 3, pp. 407–419, Nov. 2008.
- [46] G. Liu and J. Wang, "Role of Solids Retention Time on Complete Nitrification: Mechanistic Understanding and Modeling," *J. Environ. Eng.*, vol. 140, no. 1, pp. 48–56, Sep. 2013.

- [47] G. Munz, G. Mori, C. Vannini, and C. Lubello, “Kinetic parameters and inhibition response of ammonia- and nitrite-oxidizing bacteria in membrane bioreactors and conventional activated sludge processes,” *Environ. Technol.*, vol. 31, no. 14, pp. 1557–1564, Dec. 2010.
- [48] U. Wiesmann, “Biological nitrogen removal from wastewater,” *Biotechnics/wastewater*, pp. 113–154, 1994.
- [49] A. Galí, J. Dosta, M. C. M. van Loosdrecht, and J. Mata-Alvarez, “Two ways to achieve an anammox influent from real reject water treatment at lab-scale: Partial SBR nitrification and SHARON process,” *Process Biochem.*, vol. 42, no. 4, pp. 715–720, Apr. 2007.
- [50] C. Hellinga, M. C. M. van Loosdrecht, and J. J. Heijnen, “Model Based Design of a Novel Process for Nitrogen Removal from Concentrated Flows,” *Math. Comput. Model. Dyn. Syst.*, vol. 5, no. 4, pp. 351–371, Dec. 1999.
- [51] R. M. Jones *et al.*, “Simulation for operation and control of reject water treatment processes,” *Proc. Water Environ. Fed.*, vol. 2007, no. 14, pp. 4357–4372, 2007.
- [52] G. A. Keen and J. I. Prosser, “Steady state and transient growth of autotrophic nitrifying bacteria,” *Arch. Microbiol.*, vol. 147, no. 1, pp. 73–79, 1987.
- [53] S. W. Van Hulle, E. I. Volcke, J. L. Teruel, B. Donckels, M. C. van Loosdrecht, and P. A. Vanrolleghem, “Influence of temperature and pH on the kinetics of the Sharon nitritation process,” *J. Chem. Technol. Biotechnol.*, vol. 82, no. 5, pp. 471–480, May 2007.
- [54] A. Magrí *et al.*, “A Model for the Simulation of the SHARON Process: pH as a Key Factor,” *Environ. Technol.*, vol. 28, no. 3, pp. 255–265, Mar. 2007.
- [55] D. Gao, Y. Peng, and W.-M. Wu, “Kinetic Model for Biological Nitrogen Removal Using Shortcut Nitrification-Denitrification Process in Sequencing Batch Reactor,” *Environ. Sci. Technol.*, vol. 44, no. 13, pp. 5015–5021, Jul. 2010.
- [56] M. J. Kampschreur, C. Picoreanu, N. Tan, R. Kleerebezem, M. S. M. Jetten, and M. C. M. van Loosdrecht, “UNRAVELING THE SOURCE OF NITRIC OXIDE EMISSION DURING NITRIFICATION,” *Proc. Water Environ. Fed.*, vol. 2007, no. 2, pp. 843–860, Jan. 2007.
- [57] C. Rongsayamanont, T. Limpiyakorn, B. Law, and E. Khan, “Relationship between respirometric activity and community of entrapped nitrifying bacteria: Implications for partial nitrification,” *Enzyme Microb. Technol.*, vol. 46, no. 3–4, pp. 229–236, Mar. 2010.
- [58] X. Liu, M. Kim, and G. Nakhla, “Operational conditions for successful partial nitrification in a sequencing batch reactor (SBR) based on process kinetics,” *Environ. Technol.*, pp. 1–11, Jul. 2016.

- [59] V. Pambrun, E. Paul, and M. Spérandio, “Modeling the partial nitrification in sequencing batch reactor for biomass adapted to high ammonia concentrations,” *Biotechnol. Bioeng.*, vol. 95, no. 1, pp. 120–131, Sep. 2006.
- [60] V. M. Vadivelu, J. Keller, and Z. Yuan, “Stoichiometric and kinetic characterisation of *Nitrosomonas* sp. in mixed culture by decoupling the growth and energy generation processes,” *J. Biotechnol.*, vol. 126, no. 3, pp. 342–356, Nov. 2006.
- [61] R. Manser, W. Gujer, and H. Siegrist, “Consequences of mass transfer effects on the kinetics of nitrifiers,” *Water Res.*, vol. 39, no. 19, pp. 4633–4642, Nov. 2005.
- [62] H. Daebel, R. Manser, and W. Gujer, “Exploring temporal variations of oxygen saturation constants of nitrifying bacteria,” *Water Res.*, vol. 41, no. 5, pp. 1094–1102, Mar. 2007.
- [63] A. Guisasola, I. Jubany, J. A. Baeza, J. Carrera, and J. Lafuente, “Respirometric estimation of the oxygen affinity constants for biological ammonium and nitrite oxidation,” *J. Chem. Technol. Biotechnol.*, vol. 80, no. 4, pp. 388–396, Apr. 2005.
- [64] P. Dan, “Determination of ammonia oxidation bacteria kinetics in partial nitrification process using respirometric method,” *J. Sci. Technol.*, vol. 52, p. 3A, 2014.
- [65] J. Pérez, E. Costa, and J.-U. Kreft, “Conditions for partial nitrification in biofilm reactors and a kinetic explanation,” *Biotechnol. Bioeng.*, vol. 103, no. 2, pp. 282–295, Jun. 2009.
- [66] R. Canziani, V. Emondi, M. Garavaglia, F. Malpei, E. Pasinetti, and G. Buttiglieri, “Effect of oxygen concentration on biological nitrification and microbial kinetics in a cross-flow membrane bioreactor (MBR) and moving-bed biofilm reactor (MBBR) treating old landfill leachate,” *J. Membr. Sci.*, vol. 286, no. 1–2, pp. 202–212, Dec. 2006.
- [67] S. Lackner, A. Terada, H. Horn, M. Henze, and B. F. Smets, “Nitritation performance in membrane-aerated biofilm reactors differs from conventional biofilm systems,” *Water Res.*, vol. 44, no. 20, pp. 6073–6084, 2010.
- [68] T. P. W. Vannecke and E. I. P. Volcke, “Modelling microbial competition in nitrifying biofilm reactors,” *Biotechnol. Bioeng.*, vol. 112, no. 12, pp. 2550–2561, Dec. 2015.
- [69] A. Schramm, D. de Beer, J. C. van den Heuvel, S. Ottengraf, and R. Amann, “Microscale Distribution of Populations and Activities of *Nitrosospira* and *Nitrospira* spp. along a Macroscale Gradient in a Nitrifying Bioreactor: Quantification by In Situ Hybridization and the Use of Microsensors,” *Appl. Environ. Microbiol.*, vol. 65, no. 8, pp. 3690–3696, Aug. 1999.

- [70] V. M. Vadivelu, Z. Yuan, C. Fux, and J. Keller, "Stoichiometric and kinetic characterisation of *Nitrobacter* in mixed culture by decoupling the growth and energy generation processes," *Biotechnol. Bioeng.*, vol. 94, no. 6, pp. 1176–1188, Aug. 2006.
- [71] L. S. Downing and R. Nerenberg, "Effect of oxygen gradients on the activity and microbial community structure of a nitrifying, membrane-aerated biofilm," *Biotechnol. Bioeng.*, vol. 101, no. 6, pp. 1193–1204, Dec. 2008.
- [72] L. Carvallo, J. Carrera, and R. Chamy, "Nitrifying activity monitoring and kinetic parameters determination in a biofilm airlift reactor by respirometry," *Biotechnol. Lett.*, vol. 24, no. 24, pp. 2063–2066, Dec. 2002.
- [73] K. Hanaki, C. Wantawin, and S. Ohgaki, "Nitrification at low levels of dissolved oxygen with and without organic loading in a suspended-growth reactor," *Water Res.*, vol. 24, no. 3, pp. 297–302, 1990.
- [74] J.-H. Guo *et al.*, "Energy saving achieved by limited filamentous bulking sludge under low dissolved oxygen," *Bioresour. Technol.*, vol. 101, no. 4, pp. 1120–1126, Feb. 2010.
- [75] M. K. Stenstrom and R. A. Poduska, "The effect of dissolved oxygen concentration on nitrification," *Water Res.*, vol. 14, no. 6, pp. 643–649, 1980.
- [76] R. N. Mohammed, S. Abu-Alhail, and L. Xi-wu, "Long-term operation of a novel pilot-scale six tanks alternately operating activated sludge process in treating domestic wastewater," *Environ. Technol.*, vol. 35, no. 15, pp. 1874–1885, Aug. 2014.
- [77] M. C. M. Van Loosdrecht and S. J. Heijnen, "Biofilm bioreactors for wastewater treatment," *Trends Biotechnol.*, vol. 11, no. 4, pp. 117–121, Apr. 1993.
- [78] J. J. Heijnen, "Influence of dissolved oxygen concentration on nitrite accumulation in a biofilm airlift suspension reactor," *Biotechnol. Bioeng.*, vol. 53, pp. 168–178, 1997.
- [79] J. Liu, Y. Tian, D. Wang, Y. Lu, J. Zhang, and W. Zuo, "Quantitative analysis of ammonia-oxidizing bacteria in a combined system of MBR and worm reactors treating synthetic wastewater," *Bioresour. Technol.*, vol. 174, pp. 294–301, Dec. 2014.
- [80] H. Tanaka and I. J. Dunn, "Kinetics of biofilm nitrification," *Biotechnol. Bioeng.*, vol. 24, no. 3, pp. 669–689, 1982.
- [81] J. Kim and B. Lee, "Effect of temperature on nitrogen removal and microbial community composition in nitrifying biofilm reactors," in *Strategic Technology (IFOST), 2011 6th International Forum on*, 2011, vol. 1, pp. 476–479.
- [82] Z. Tonkovic, "Nitrite accumulation at the Mornington sewage treatment plant—causes and significance," in *19th Biennial International Conference, Water Quality International*, 1998, pp. 165–172.

- [83] A. Rodriguez-Sanchez, A. Gonzalez-Martinez, M. Martinez-Toledo, M. Garcia-Ruiz, F. Osorio, and J. Gonzalez-Lopez, "The Effect of Influent Characteristics and Operational Conditions over the Performance and Microbial Community Structure of Partial Nitrification Reactors," *Water*, vol. 6, no. 7, pp. 1905–1924, Jun. 2014.
- [84] B. Balmelle, K. M. Nguyen, B. Capdeville, J. C. Cornier, and A. Deguin, "Study of factors controlling nitrite build-up in biological processes for water nitrification," *Water Sci. Technol.*, vol. 26, no. 5–6, pp. 1017–1025, 1992.
- [85] D. Bougard, N. Bernet, D. Chèneby, and J.-P. Delgenès, "Nitrification of a high-strength wastewater in an inverse turbulent bed reactor: Effect of temperature on nitrite accumulation," *Process Biochem.*, vol. 41, no. 1, pp. 106–113, Jan. 2006.
- [86] S. Ge, S. Wang, X. Yang, S. Qiu, B. Li, and Y. Peng, "Detection of nitrifiers and evaluation of partial nitrification for wastewater treatment: A review," *Chemosphere*, vol. 140, pp. 85–98, Dec. 2015.
- [87] A. C. Anthonisen, R. C. Loehr, T. B. S. Prakasam, and E. G. Srinath, "Inhibition of nitrification by ammonia and nitrous acid," *J. Water Pollut. Control Fed.*, pp. 835–852, 1976.
- [88] W. Bae, S. Baek, J. Chung, and Y. Lee, "Optimal operational factors for nitrite accumulation in batch reactors," *Biodegradation*, vol. 12, no. 5, pp. 359–366, 2001.
- [89] U. Abeling and C. F. Seyfried, "Anaerobic-aerobic treatment of high-strength ammonium wastewater-nitrogen removal via nitrite," *Water Sci. Technol.*, vol. 26, no. 5–6, pp. 1007–1015, 1992.
- [90] M. Beccari, R. Passino, R. Ramadori, and V. Tandoi, "Kinetics of dissimilatory nitrate and nitrite reduction in suspended growth culture," *J. Water Pollut. Control Fed.*, pp. 58–64, 1983.
- [91] Y. Zhou, A. Oehmen, M. Lim, V. Vadivelu, and W. J. Ng, "The role of nitrite and free nitrous acid (FNA) in wastewater treatment plants," *Water Res.*, vol. 45, no. 15, pp. 4672–4682, Oct. 2011.
- [92] C. Glass, J. Silverstein, and J. Oh, "Inhibition of Denitrification in Activated Sludge by Nitrite," *Water Environ. Res.*, vol. 69, no. 6, pp. 1086–1093, Sep. 1997.
- [93] J. E. Alleman, "Elevated nitrite occurrence in biological wastewater treatment systems," *Water Sci. Technol.*, vol. 17, no. 2–3, pp. 409–419, 1985.
- [94] Y. He, W. Tao, Z. Wang, and W. Shayya, "Effects of pH and seasonal temperature variation on simultaneous partial nitrification and anammox in free-water surface wetlands," *J. Environ. Manage.*, vol. 110, pp. 103–109, Nov. 2012.

- [95] S. Villaverde, P. A. Garcia-Encina, and F. Fdz-Polanco, "Influence of pH over nitrifying biofilm activity in submerged biofilters," *Water Res.*, vol. 31, no. 5, pp. 1180–1186, 1997.
- [96] E. Bock, H.-P. Koops, and H. Harms, "Cell biology of nitrifying bacteria.," 1986.
- [97] C. Wan, X. Yang, D.-J. Lee, S. Sun, X. Liu, and P. Zhang, "Influence of hydraulic retention time on partial nitrification of continuous-flow aerobic granular-sludge reactor," *Environ. Technol.*, vol. 35, no. 14, pp. 1760–1765, Jul. 2014.
- [98] J. Li, D. Yu, and P. Zhang, "Partial nitrification in a sequencing batch reactor treating acrylic fiber wastewater," *Biodegradation*, vol. 24, no. 3, pp. 427–435, Jun. 2013.
- [99] L. Shen, Y. Yao, and F. Meng, "Reactor performance and microbial ecology of a nitritation membrane bioreactor," *J. Membr. Sci.*, vol. 462, pp. 139–146, Jul. 2014.
- [100] A. González-Martínez *et al.*, "Biological and technical study of a partial-SHARON reactor at laboratory scale: effect of hydraulic retention time," *Bioprocess Biosyst. Eng.*, vol. 36, no. 2, pp. 173–184, Feb. 2013.
- [101] J. C. Leyva-Díaz, A. González-Martínez, J. González-López, M. M. Muñío, and J. M. Poyatos, "Kinetic modeling and microbiological study of two-step nitrification in a membrane bioreactor and hybrid moving bed biofilm reactor–membrane bioreactor for wastewater treatment," *Chem. Eng. J.*, vol. 259, pp. 692–702, Jan. 2015.
- [102] R. Ganigué, H. López, M. D. Balaguer, and J. Colprim, "Partial ammonium oxidation to nitrite of high ammonium content urban landfill leachates," *Water Res.*, vol. 41, no. 15, pp. 3317–3326, Aug. 2007.
- [103] U. Durán, A. Val del Río, J. L. Campos, A. Mosquera-Corral, and R. Méndez, "Enhanced ammonia removal at room temperature by pH controlled partial nitrification and subsequent anaerobic ammonium oxidation," *Environ. Technol.*, vol. 35, no. 4, pp. 383–390, Feb. 2014.
- [104] A. Galí, J. Dosta, S. Macé, and J. Mata-Alvarez, "Comparison of Reject Water Treatment with Nitrification/Denitrification via Nitrite in SBR and Sharon Chemostat Process," *Environ. Technol.*, vol. 28, no. 2, pp. 173–176, Feb. 2007.
- [105] J. A. Torà, J. Lafuente, J. Carrera, and J. A. Baeza, "Fast start-up and controlled operation during a long-term period of a high-rate partial nitrification activated sludge system," *Environ. Technol.*, vol. 33, no. 12, pp. 1361–1366, Jun. 2012.

- [106]J. J. Heijnen, A. Mulder, W. Enger, and F. Hoeks, “Review on the application of anaerobic fluidized bed reactors in waste-water treatment,” *Chem. Eng. J.*, vol. 41, no. 3, pp. B37–B50, Sep. 1989.
- [107]Q. Sui, C. Liu, H. Dong, and Z. Zhu, “Effect of ammonium nitrogen concentration on the ammonia-oxidizing bacteria community in a membrane bioreactor for the treatment of anaerobically digested swine wastewater,” *J. Biosci. Bioeng.*, vol. 118, no. 3, pp. 277–283, Sep. 2014.
- [108]M. Zhang, P. G. Lawlor, Z. Hu, and X. Zhan, “Nutrient removal from separated pig manure digestate liquid using hybrid biofilters,” *Environ. Technol.*, vol. 34, no. 5, pp. 645–651, Mar. 2013.
- [109]N. Kishida, J.-H. Kim, M. Chen, H. Sasaki, and R. Sudo, “Effectiveness of oxidation-reduction potential and pH as monitoring and control parameters for nitrogen removal in swine wastewater treatment by sequencing batch reactors,” *J. Biosci. Bioeng.*, vol. 96, no. 3, pp. 285–290, Jan. 2003.
- [110]S. Bagchi, R. Biswas, K. Roychoudhury, and T. Nandy, “Stable partial nitrification in an up-flow fixed-bed bioreactor under an oxygen-limiting environment,” *Environ. Eng. Sci.*, vol. 26, no. 8, pp. 1309–1318, 2009.
- [111]Z. Liang *et al.*, “A control strategy of partial nitritation in a fixed bed biofilm reactor,” *Bioresour. Technol.*, vol. 102, no. 2, pp. 710–715, Jan. 2011.
- [112]B. Rusten, B. Eikebrokk, Y. Ulgenes, and E. Lygren, “Design and operations of the Kaldnes moving bed biofilm reactors,” *Aquac. Eng.*, vol. 34, no. 3, pp. 322–331, May 2006.
- [113]C. Nicoletta, M. C. M. Van Loosdrecht, and J. J. Heijnen, “Wastewater treatment with particulate biofilm reactors,” *J. Biotechnol.*, vol. 80, no. 1, pp. 1–33, 2000.
- [114]K. Mishima and M. Nakamura, “Self-immobilization of aerobic activated sludge—a pilot study of the aerobic upflow sludge blanket process in municipal sewage treatment,” *Water Sci. Technol.*, vol. 23, no. 4–6, pp. 981–990, 1991.
- [115]An-Jie Li, Xiao-Yan Li, Xiang-Chun Quan, and Zhi-Feng Yang, “Aerobic Sludge Granulation for Partial Nitrification of Ammonia-Rich Inorganic Wastewater,” *Environ. Eng. Manag. J. EEMJ*, vol. 12, no. 7, pp. 1375–1380, Jul. 2013.
- [116]A. C. Anthonisen, R. C. Loehr, T. B. S. Prakasam, and E. G. Srinath, “Inhibition of nitrification by ammonia and nitrous acid,” *J. Water Pollut. Control Fed.*, pp. 835–852, 1976.
- [117]Y. Zhou, A. Oehmen, M. Lim, V. Vadivelu, and W. J. Ng, “The role of nitrite and free nitrous acid (FNA) in wastewater treatment plants,” *Water Res.*, vol. 45, no. 15, pp. 4672–4682, Oct. 2011.

- [118]E. Bock, H.-P. Koops, and H. Harms, “Cell biology of nitrifying bacteria.,” 1986.
- [119]J. Li, D. Yu, and P. Zhang, “Partial nitrification in a sequencing batch reactor treating acrylic fiber wastewater,” *Biodegradation*, vol. 24, no. 3, pp. 427–435, Jun. 2013.
- [120]L. Wang, G. Zeng, Z. Yang, L. Luo, H. Xu, and J. Huang, “Operation of partial nitrification to nitrite of landfill leachate and its performance with respect to different oxygen conditions,” *Biochem. Eng. J.*, vol. 87, pp. 62–68, Jun. 2014.
- [121]J. E. Alleman, “Elevated nitrite occurrence in biological wastewater treatment systems,” *Water Sci. Technol.*, vol. 17, no. 2–3, pp. 409–419, 1985.
- [122]M. Bellucci and T. P. Curtis, “Ammonia-Oxidizing Bacteria in Wastewater,” in *Methods in Enzymology*, vol. 496, Elsevier, 2011, pp. 269–286.
- [123]J. Geets *et al.*, “Real-time PCR assay for the simultaneous quantification of nitrifying and denitrifying bacteria in activated sludge,” *Appl. Microbiol. Biotechnol.*, vol. 75, no. 1, pp. 211–221, May 2007.
- [124]L.-Y. Chai *et al.*, “Partial nitrification in an air-lift reactor with long-term feeding of increasing ammonium concentrations,” *Bioresour. Technol.*, vol. 185, pp. 134–142, Jun. 2015.
- [125]H.-D. Park and D. R. Noguera, “Evaluating the effect of dissolved oxygen on ammonia-oxidizing bacterial communities in activated sludge,” *Water Res.*, vol. 38, no. 14–15, pp. 3275–3286, Aug. 2004.
- [126]W. Bae, S. Baek, J. Chung, and Y. Lee, “Optimal operational factors for nitrite accumulation in batch reactors,” *Biodegradation*, vol. 12, no. 5, pp. 359–366, 2001.
- [127]Y. He, W. Tao, Z. Wang, and W. Shayya, “Effects of pH and seasonal temperature variation on simultaneous partial nitrification and anammox in free-water surface wetlands,” *J. Environ. Manage.*, vol. 110, pp. 103–109, Nov. 2012.
- [128]D. Paredes, P. Kusch, T. S. A. Mbwette, F. Stange, R. A. Müller, and H. Köser, “New Aspects of Microbial Nitrogen Transformations in the Context of Wastewater Treatment – A Review,” *Eng. Life Sci.*, vol. 7, no. 1, pp. 13–25, Feb. 2007.
- [129]R.-C. Jin, Q.-Q. Zhang, J.-H. Liu, B.-E. Yang, K. Wu, and P. Zheng, “Performance and stability of the partial nitrification process for nitrogen removal from monosodium glutamate wastewater,” *Sep. Purif. Technol.*, vol. 103, pp. 195–202, Jan. 2013.
- [130]H.-P. Chuang, A. Ohashi, H. Imachi, M. Tandukar, and H. Harada, “Effective partial nitrification to nitrite by down-flow hanging sponge reactor under

- limited oxygen condition,” *Water Res.*, vol. 41, no. 2, pp. 295–302, Jan. 2007.
- [131] B. Wett and W. Rauch, “The role of inorganic carbon limitation in biological nitrogen removal of extremely ammonia concentrated wastewater,” *Water Res.*, vol. 37, no. 5, pp. 1100–1110, Mar. 2003.
- [132] M. Soliman and A. Eldyasti, “Development of partial nitrification as a first step of nitrite shunt process in a Sequential Batch Reactor (SBR) using Ammonium Oxidizing Bacteria (AOB) controlled by mixing regime,” *Bioresour. Technol.*, vol. 221, pp. 85–95, Dec. 2016.
- [133] J. B. Xavier, M. K. D. Kreuk, C. Picioreanu, and M. C. M. V. Loosdrecht, “Multi-Scale Individual-Based Model of Microbial and Bioconversion Dynamics in Aerobic Granular Sludge,” *ResearchGate*, vol. 41, no. 18, pp. 6410–6417, Oct. 2007.
- [134] R. Ganigué, E. I. P. Volcke, S. Puig, M. D. Balaguer, J. Colprim, and G. Sin, “Systematic model development for partial nitrification of landfill leachate in a SBR,” *Water Sci. Technol.*, vol. 61, no. 9, pp. 2199–2210, May 2010.
- [135] L. Corominas Tabares, *Control and optimization of an SBR for nitrogen removal: from model calibration to plant operation*. Universitat de Girona, 2006.
- [136] R. Brun, M. Kühni, H. Siegrist, W. Gujer, and P. Reichert, “Practical Identifiability of ASM2d Parameters—Systematic Selection and Tuning of Parameter Subsets,” *ResearchGate*, vol. 36, no. 16, pp. 4113–27, Oct. 2002.
- [137] M. S. Moussa, C. M. Hooijmans, H. J. Lubberding, H. J. Gijzen, and M. C. M. van Loosdrecht, “Modelling nitrification, heterotrophic growth and predation in activated sludge,” *Water Res.*, vol. 39, no. 20, pp. 5080–5098, Dec. 2005.
- [138] W. Bae, S. Baek, J. Chung, and Y. Lee, “Optimal operational factors for nitrite accumulation in batch reactors,” *Biodegradation*, vol. 12, no. 5, pp. 359–366, Sep. 2001.
- [139] W. Jianlong and Y. Ning, “Partial nitrification under limited dissolved oxygen conditions,” *Process Biochem.*, vol. 39, no. 10, pp. 1223–1229, Jun. 2004.
- [140] G. Ruiz, D. Jeison, and R. Chamy, “Nitrification with high nitrite accumulation for the treatment of wastewater with high ammonia concentration,” *Water Res.*, vol. 37, no. 6, pp. 1371–1377, Mar. 2003.