

**FREE AMINO ACIDS IN ARCTIC SALT-MARSH COASTAL SITES  
AND PLANT NITROGEN ACQUISITION**

by

Hugh A. L. Henry

A thesis submitted in conformity with the requirements for the Degree of Doctor of  
Philosophy, Graduate Department of Botany, University of Toronto

© Copyright by Hugh Henry, 2003



National Library  
of Canada

Acquisitions and  
Bibliographic Services

395 Wellington Street  
Ottawa ON K1A 0N4  
Canada

Bibliothèque nationale  
du Canada

Acquisitions et  
services bibliographiques

395, rue Wellington  
Ottawa ON K1A 0N4  
Canada

Your file Votre référence

Our file Notre référence

The author has granted a non-exclusive licence allowing the National Library of Canada to reproduce, loan, distribute or sell copies of this thesis in microform, paper or electronic formats.

The author retains ownership of the copyright in this thesis. Neither the thesis nor substantial extracts from it may be printed or otherwise reproduced without the author's permission.

L'auteur a accordé une licence non exclusive permettant à la Bibliothèque nationale du Canada de reproduire, prêter, distribuer ou vendre des copies de cette thèse sous la forme de microfiche/film, de reproduction sur papier ou sur format électronique.

L'auteur conserve la propriété du droit d'auteur qui protège cette thèse. Ni la thèse ni des extraits substantiels de celle-ci ne doivent être imprimés ou autrement reproduits sans son autorisation.

0-612-78024-4

Canada

# Free amino acids in Arctic salt-marsh coastal sites and plant nitrogen acquisition

Hugh A. L. Henry

Degree of Doctor of Philosophy

Graduate Department of Botany, University of Toronto, 2003

## Abstract

The importance of free amino acids as a source of plant nitrogen was examined in an Arctic coastal salt-marsh. Concentrations of inorganic nitrogen in salt-marsh soils were low relative to those reported for most temperate soils, whereas soluble organic nitrogen concentrations of salt-marsh soils were relatively high; the median ratio of free amino acid nitrogen as a proportion of ammonium nitrogen was 0.36 and amino acid concentrations exceeded those of ammonium in 24 % of samples. Growth of the salt-marsh grass *Puccinellia phryganodes* on glycine in a continuous flow hydroponic medium was similar to growth on ammonium ions at an equivalent concentration of nitrogen. Furthermore, in short-term excised root uptake experiments, rates of glycine uptake were equal to rates of ammonium and nitrate uptake combined when roots were provided with all three nitrogen substrates at equal concentrations. Amino acid uptake relative to ammonium uptake was favoured at high temperatures, high salinity and low pH. Free amino acids turned over rapidly in the soil, with half-lives in the soil solution ranging from 8 - 23 h for glycine, compared with ranges of 6 - 15 h and 6 - 16 h for ammonium and nitrate ions, respectively. Plant incorporation of  $^{15}\text{N}$  tracer injected into soil cores was 56, 83, and 68% of incorporation by soil microorganisms for glycine, ammonium and nitrate ions, respectively. The simultaneous incorporation of  $^{13}\text{C}$  and  $^{15}\text{N}$

into plant roots following injection of  $^{13}\text{C}^{15}\text{N}$ -glycine into soil cores indicated that at least a portion of this amino acid was absorbed intact. In a model of the dynamics of nitrogen movement in an Arctic salt-marsh grazed and grubbed by geese, the direct uptake of organic nitrogen by plant roots was required to obtain rates of mineralization consistent with empirical estimates. Overall, these results indicate that free amino acids are likely a substantial contribution to plant nitrogen nutrition in Arctic coastal marshes.

## Acknowledgements

Foremost, I thank Robert Jefferies for his guidance and friendship. I could not have asked for a more knowledgeable or generous supervisor. I also thank my committee members, Ken Abraham, Eduardo Blumwald, Johan Hellebust, Herbert Kronzucker, the late Donn Kushner and Vic Timmer, who made my committee meetings both enjoyable and richly rewarding.

I am indebted to my field assistants, Dawn Davidson, Michael Warnock and Rachel Sturge, for their careful and efficient work and cheerful company. I have also benefitted greatly from the assistance and companionship of the students and researchers at the La Pérouse Bay Field Station. In particular, I thank Paul Matulonis for his benevolence and wise counsel and Chris Witte for his camaraderie. Robert Rockwell also provided much logistical support and good cheer.

My lab-mates, Esther Chang, Jennie McLaren and Jackie Ngai must be thanked for enduring my idiosyncrasies and for sharing their knowledge and enthusiasm. I also thank my friend, Marcel Dorken, for providing needed distraction and occasional scientific debate. I am grateful to Deb Tam for her technical assistance and kindness.

I especially thank my life-long love Nicola Cason for her support and companionship. I owe much to her for instilling me with confidence and happiness. I also admire the example set by my parents, Bunny and Sean Henry, and cannot thank them enough for their unconditional love and support.

Lastly, I am grateful for financial support provided by the Association of Canadian Universities, the Canadian Geographic Society, the Dr. F.M. Hill Ontario

Graduate Scholarship in Science and Technology, the Natural Sciences and Engineering  
Research Council of Canada, the Northern Scientific Training Program, the University of  
Toronto Department of Botany and the supporters of the Hudson Bay Project.

## Contribution of Other Investigators

R. L. Jefferies, the second author on the submitted versions of Chapters 2, 3 and 4, assisted in experimental design and contributed substantially to the editing of all thesis chapters. Chapter 2 has been published (Henry & Jefferies. 2002. *Plant, Cell & Environment* 25: 665-676), Chapter 3 has been accepted by *Plant, Cell & Environment* and the manuscript version of Chapter 4 is in the final stages of preparation. N. A. Walker is the primary author of Chapter 5, which will be submitted to the *Journal of Ecology*. He generated the primary code for the model presented in Chapter 5 and contributed to the writing of the manuscript. The third and fourth authors of Chapter 5 are D. Wilson, who contributed data and R. L. Jefferies, who contributed data and wrote portions of the manuscript.

# Table of Contents

Abstract	ii
Acknowledgements	iv
Contribution of Other Investigators	vi
Table of Contents	vii
List of Tables	xii
List of Figures	xiii
<b>Chapter 1: General Introduction</b>	<b>1</b>
1.1 Nitrogen limitation	1
1.1.1 The universal inaccessibility of nitrogen (N)	1
1.1.2 Forms of nitrogen available to plants in Arctic ecosystems	4
1.1.3 The potential role of free amino acids in Arctic coastal marshes	7
1.2 Soil free amino acids	8
1.3 Plant amino acid uptake	10
1.3.1 Uptake from hydroponic media	10
1.3.2 Amino acid uptake <i>in situ</i>	13
1.3.3 Competition between plants and soil microorganisms	14
1.3.4 The role of mycorrhizae	15
1.3.5 Modelling plant amino acids uptake	16
1.4 N assimilation	17
1.5 Outline of thesis	19

<b>Chapter 2: Free amino acid, ammonium and nitrate concentrations in soil solutions of a grazed coastal marsh in relation to plant growth.</b>	22
2.1 Abstract	22
2.2 Introduction	23
2.3 Material and methods	25
2.3.1 Study sites	25
2.3.2 Soil and faecal material sampling	26
2.3.3 Soluble nitrogen analyses	27
2.3.4 Continuous flow experiment	28
2.3.5 Data analyses	30
2.4 Results	31
2.4.1 Temporal and spatial trends in soluble N	31
2.4.2 Continuous flow uptake experiment	38
2.5 Discussion	42
2.5.1 Temporal and spatial trends in soluble N	42
2.5.2 Amino acid profiles	44
2.5.3 Continuous flow experiment	45
<b>Chapter 3: Interactions in the uptake of amino acids, ammonium and nitrate ions in the Arctic salt-marsh grass, <i>Puccinellia phryganodes</i>.</b>	49
3.1 Abstract	49
3.2 Introduction	50
3.3 Methods	53
3.3.1 Study species and site description	53

3.3.2 Excised root experiments	54
3.3.3 Data analyses	57
3.4 Results	58
3.4.1 Uptake of <sup>15</sup> N by excised roots	58
3.4.2 Effects of salinity, temperature, pH and competition between N sources on uptake rates	61
3.4.3 Regulation of N uptake by substrates	65
3.5 Discussion	69
<b>Chapter 4: Plant amino acid uptake, soluble N turnover and microbial biomass dynamics in a grazed Arctic coastal marsh.</b>	77
4.1 Abstract	77
4.2 Introduction	78
4.3 Material and methods	80
4.3.1 Study sites	80
4.3.2 N turnover	83
4.3.3 <i>In situ</i> uptake	84
4.3.4 Microbial biomass	85
4.3.5 Data analyses	86
4.4 Results	87
4.5 Discussion	93
<b>Chapter 5: A model of the dynamics of nitrogen movement in an Arctic salt-marsh foraged by geese.</b>	99
5.1 Summary	99

5.2 Introduction	100
5.3 Methods	104
5.3.1 Site description	104
5.3.2 Nitrogen budgets	105
5.3.3 Model description	106
5.3.4 Parameter values, initial conditions and calibration	120
5.3.5 Sensitivity analyses	123
5.4 Results	124
5.4.1 LPBN - General observations	124
5.4.2 Steady-state simulations	125
5.4.3 Sensitivity analyses	129
5.5 Discussion	135
5.6 Future work	138
<b>Chapter 6: General Discussion</b>	140
6.1 Overview	140
6.2 Availability of soluble nitrogen for plant uptake in Arctic salt-marsh soils	141
6.3 Uptake of soluble nitrogen by <i>Puccinellia phryganodes</i>	145
6.4 Implications of soluble organic nitrogen uptake for ecosystem N dynamics	154
6.5 Conclusions	157
<b>Appendices</b>	159
Appendix 1. Preparation of Hoagland's solution for hydroponic media	159
Appendix 2. Uptake of <sup>15</sup> N-substrates by excised roots	160

Appendix 3. Total N determination using alkaline persulfate oxidation	161
Appendix 4. $^{15}\text{N}$ turnover and uptake by plants <i>in situ</i>	162
Appendix 5. Microbial C and N estimation using chloroform fumigation extraction	164
<b>References</b>	<b>165</b>

## List of Tables

<b>Table 1.1.</b> Average concentration of mineral nutrients in plant shoot dry matter that are sufficient for adequate growth.	3
<b>Table 2.1.</b> Range of estimates for daily nitrogen flux across root surface and transpirational flow required to maintain a constant net supply of nitrogen to the root surface via mass flow for tillers of <i>P. phryganodes</i> grown in hydroponic culture.	41
<b>Table 3.1.</b> Uptake kinetics of <sup>15</sup> N-glycine and <sup>15</sup> N-ammonium by excised roots of <i>Puccinellia phryganodes</i> at low and moderate salinity (50 mM and 150 mM NaCl, respectively).	62
<b>Table 3.2.</b> Uptake rates of 10 μM and 100 μM <sup>15</sup> N-glycine and <sup>15</sup> N-ammonium ions by excised roots of <i>Puccinellia phryganodes</i> at 2, 5 and 18 °C.	62
<b>Table 3.3.</b> Uptake rates of 100 μM <sup>15</sup> N-glycine, <sup>15</sup> N-ammonium and <sup>15</sup> N-nitrate by excised roots of <i>Puccinellia phryganodes</i> at a pH 5.7, 7.0 and 8.2.	63
<b>Table 3.4.</b> Uptake kinetics of <sup>15</sup> N-glycine and <sup>15</sup> N-ammonium ions by excised roots of <i>Puccinellia phryganodes</i> in the presence and absence of unlabelled competing nitrogen sources. All tillers were grown on NH <sub>4</sub> NO <sub>3</sub> .	63
<b>Table 3.5.</b> Uptake kinetics of <sup>15</sup> N-glycine, <sup>15</sup> N-glutamic acid and <sup>15</sup> N-aspartic acid by excised roots of <i>Puccinellia phryganodes</i> in the presence and absence of a mixture of 100 μM unlabelled amino acids (a.a.) (equal concentrations of alanine, aspartic acid, glutamic acid, glycine, leucine, lysine and proline).	64
<b>Table 4.1.</b> Summary of temperature, soil moisture and plant biomass data for dates on which N turnover and uptake experiemnts were conducted.	82
<b>Table 5.1.</b> a) State Equations for LPBN. Equations for the model year b) Rate equations for LPBN c) Equations for linking successive integrations (model years, for year t).	114
<b>Table 5.2.</b> Timings of processes during the model year. Times in days at which individual processes are changed in rate during the model year of 120 days. Processes not listed are on at constant rate the whole year. Day 1: goose arrival; Day 24: plant growth; Day 36: hatch; Day 84: departure in autumn.	117
<b>Table 5.3.</b> a) parameters and b) initial conditions for LPBN to match the budgets.	121
<b>Table 5.4.</b> Comparison of model output with data from N budgets in the presence and absence of geese (Figs. 1a, 1b).	123

## List of Figures

<b>Fig. 1.1</b> Simplified flow diagram of nitrogen (N) between the atmosphere and ecosystems.	2
<b>Fig. 1.2.</b> a) Traditional model of internal cycling of nitrogen within ecosystems. b) Proposed nitrogen cycling model for Arctic systems (Chapin 1995). c) Proposed nitrogen cycling model for Arctic salt-marsh systems.	5
<b>Fig. 1.3.</b> Processes that determine the supply rate of free amino acids to the root surface. The dotted line denotes the division between the bulk soil solution and the rhizosphere.	11
<b>Fig. 1.4.</b> Overview of amino acid biosynthesis in plants.	18
<b>Fig. 1.5.</b> Outline of experimental and modelling approaches presented in the thesis and their associated scales of observation.	21
<b>Fig. 2.1.</b> Seasonal trends in persulfate oxidation estimates of total soluble nitrogen in soil solution samples collected from a) the intertidal zone and b) the supratidal zone of a salt-marsh at La Pérouse Bay, Manitoba, over 14 months.	32
<b>Fig. 2.2.</b> Seasonal trends in free amino acids, ammonium and nitrate concentrations in soil solution samples collected from a) the intertidal zone and b) the supratidal zone of a salt-marsh at La Pérouse Bay, Manitoba, over 14 months.	33
<b>Fig. 2.3.</b> Distribution of total free amino acid nitrogen as a proportion of ammonium nitrogen in soil solution samples collected during the growing seasons of 1999 and 2000.	34
<b>Fig. 2.4.</b> Mean concentrations of amino acids present in bulk soil solutions of a) the intertidal zone and b) the supratidal zone of a salt-marsh at La Pérouse Bay, Manitoba. Data are pooled for sampling dates where the mean soil temperature was greater than 2 °C and less than 2 °C.	36
<b>Fig. 2.5.</b> Mean concentrations of amino acids present in faecal extracts and bulk soil solution expressed as a percentage of the total free amino acid concentration for samples collected on 30 June and 21 July 1999.	37
<b>Fig. 2.6.</b> Plots of a) total dry weight versus day, b) total nitrogen at final harvest versus N concentration in the growth solution, c) whole plant %N versus day and d) root:shoot ratio versus day for individual tillers of <i>Puccinellia phryganodes</i> grown in hydroponic culture at fixed nitrogen concentrations in the field at La Pérouse Bay, Manitoba, from 22 June to 4 August 2000.	39

- Fig. 3.1.** Plots of uptake rate versus substrate concentration for excised roots of *P. phryganodes* provided with  $^{15}\text{N}$  and  $^{13}\text{C}$ -labelled substrates in short-term uptake experiments (all tillers grown on  $\text{NH}_4\text{NO}_3$ ). 59
- Fig. 3.2.** Plots of a)  $^{15}\text{N}$ -glycine uptake, b)  $^{15}\text{N}$ -ammonium uptake and c)  $^{15}\text{N}$ -nitrate uptake by excised roots of *Puccinellia phryganodes* at an external  $^{15}\text{N}$  concentration of 100  $\mu\text{M}$ . Treatments refer to the nitrogen source tillers were grown on until day 0. The mixed treatment refers to tillers grown on equal concentrations of glycine, ammonium and nitrate at the same total nitrogen concentration as other nitrogen treatments. Thereafter, tillers were grown on the same nitrogen source as used in  $^{15}\text{N}$  uptake trials. 66
- Fig. 3.3.** Summary of effects high salinity, cold temperature, acidic pH and external concentrations of glycine, ammonium and nitrate on rates of uptake of glycine, ammonium and nitrate in *Puccinellia phryganodes*. 76
- Fig. 4.1.** Half-lives of  $^{15}\text{N}$  turnover for  $^{15}\text{N}$ -glycine,  $^{15}\text{N}$ -leucine,  $^{15}\text{NH}_4\text{Cl}$  and  $\text{K}^{15}\text{NO}_3$  injected into soil cores collected from a) the intertidal zone and b) the supratidal zone on 25 June and 12 July, 2000 and 17 June and 9 July, 2001. 88
- Fig. 4.2** Incorporation after 24 h of a)  $^{13}\text{C}$  into roots of *P. phryganodes*, b)  $^{15}\text{N}$  into shoots of *P. phryganodes*, c)  $^{15}\text{N}$  into roots of *P. phryganodes* and d)  $^{15}\text{N}$  into microbial biomass following injection of  $^{13}\text{C}^{15}\text{N}$ -glycine,  $^{15}\text{NH}_4\text{Cl}$  and  $\text{K}^{15}\text{NO}_3$  into soil cores on 14 July, 2000 and 9 July, 2001. 90
- Fig. 4.3.** a) Extractable microbial C, b) extractable microbial N and c) C/N ratio of microbial extracts of soil cores on 6 June, 4 July and 26 July, 2001. Bar and lines represent mean and standard error, respectively (n=3). 92
- Fig. 4.4** Pie charts displaying the proportion of  $^{15}\text{N}$  partitioned into plant tissue, microbial biomass and the extractable soil fraction for soil injections of a) glycine, b) ammonium and c) nitrate. 94
- Fig. 5.1.** a) Representative sward of graminoid vegetation in the intertidal zone of the salt-marsh at La Pérouse Bay, Manitoba. Both goose-grazed (unexclosed) and ungrazed (exclosed) portions of sward are visible. b) Bare sediments exposed as a result of goose grubbing. 102
- Fig. 5.2.** Annual N budgets for a) a grazed and b) an ungrazed intertidal salt marsh at La Pérouse Bay, Manitoba. 107
- Fig. 5.3.** a) Flow of N among compartments in the Arctic salt-marsh N transport model. b) Gains and losses in sward area. 111

**Fig. 5.4.** Intra-annual trends in N compartment sizes for the salt-marsh N transport model a) in the presence of geese and b) in the absence of geese. Some timed seasonal events are noted at the top. 126

**Fig. 5.5.** a) Relative Net Goose N gain for 10 % increases in individual i) goose parameters, ii) soil parameters, iii) plant parameters and iv) initial conditions relative to steady-state net Goose N gain in the presence of grazing. b) Primary production for 10 % increases in individual i) goose parameters relative to steady-state primary production in the presence of grazing. 130

**Fig. 5.6.** a) Relative sward area remaining (end of the season values) for 10% changes in model input parameters. Only parameters eliciting a decrease in area of more than 0.5% after 50 years are shown. b) Relative sward area remaining at the end of the growing season for increments of 0.02 in goose survival. c) Relative sward area remaining after 50 years (end of season values) as a function of grubbing rate for increments of 0.02 in goose survival. 133

## Chapter 1: General Introduction

### 1.1 Nitrogen limitation

#### 1.1.1 The universal inaccessibility of nitrogen (N)

The lack of access to nitrogen in forms that can be used for growth and reproduction of organisms is one of the major restrictions limiting the abundance of different species of animals, micro-organisms and plants (White 1993). The universal inaccessibility of nitrogen can be attributed to numerous processes that limit its availability at different trophic levels. First, the absolute amount of nitrogen available in the biosphere for organic synthesis by plants is scarce (Fig. 1.1); although nitrogen is the major component of the atmosphere, 99.95% exists as extremely inert dinitrogen gas (Sprenst 1987). Only a small fraction of atmospheric N is added to ecosystems each year (110-130 Tg yr<sup>-1</sup>), primarily by nitrogen-fixing microorganisms, and a roughly equivalent amount (135 Tg yr<sup>-1</sup>), that is increasing, is added by industrial fixation, internal combustion engines and leguminous crop plants (Vitousek 1994). Of the small fraction of combined N in terrestrial and aquatic ecosystems, roughly half is in inorganic form, most of which is available for uptake by plants. Of the remaining half, which comprises of organic nitrogen, 95% is bound in necromass in litter and soil or particulate matter in aquatic systems and is not readily available for plant uptake (White 1993). Despite the relative scarcity of N in available forms for plant uptake, N demand by plants is high relative to that of other mineral nutrients (Epstein 1965) (Table 1.1). As a result of a high N demand in plants, the availability of nitrogenous compounds relative to carbon, light and water is one of the most critical factors that affects plant production (Ågren 1985).

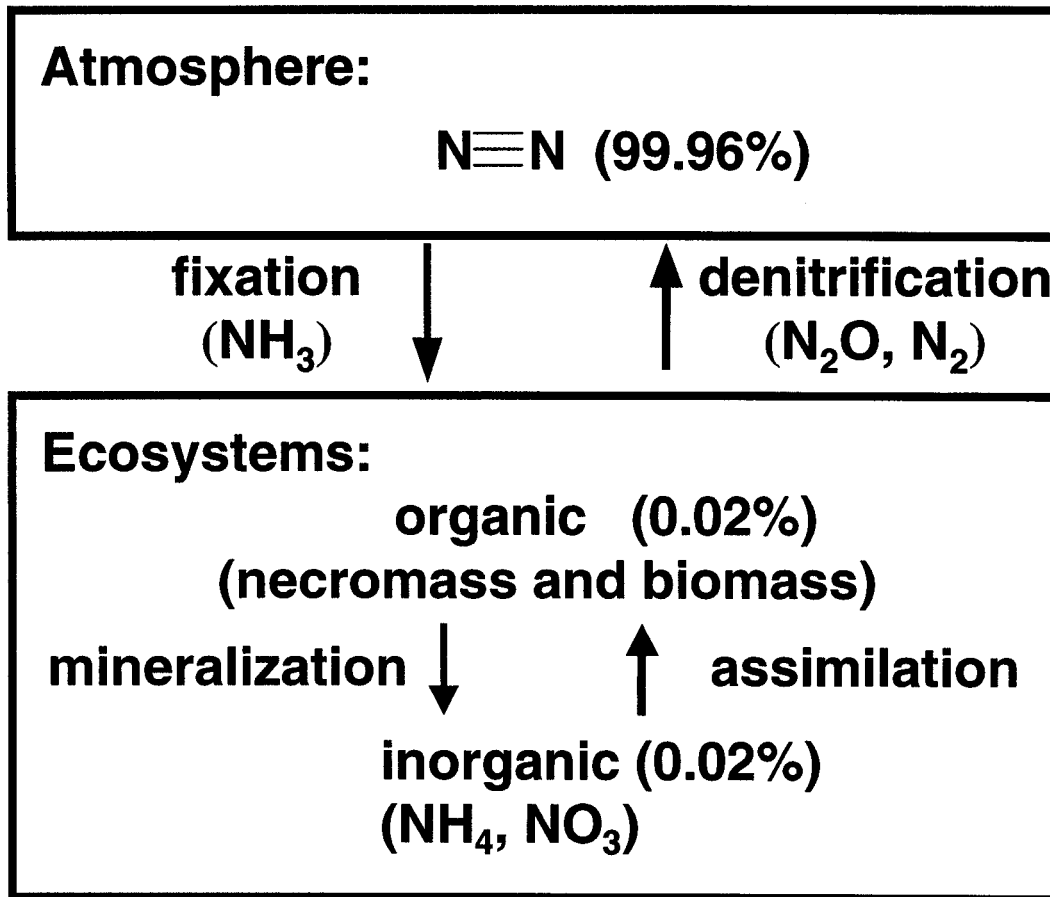

**Fig. 1.1** Simplified flow diagram of nitrogen (N) between the atmosphere and ecosystems. The mass balance of N in the biosphere is noted in parentheses.

**Table 1.1.** Average concentrations of mineral nutrients in plant shoot dry matter that are sufficient for adequate growth.

Element	average concentration ( $\mu\text{mol g}^{-1}$ dry wt)
Nitrogen	1000 *
Potassium	250
Calcium	125
Magnesium	80
Phosphorus	60
Sulfur	30
Chlorine	3
Boron	2
Iron	2
Manganese	1
Zinc	0.3
Copper	0.1
Nickel	0.001
Molybdenum	0.001

\* 1000  $\mu\text{mol g}^{-1}$  dry wt of nitrogen is equal to approximately 1.4 % of plant dry weight.

(modified from Epstein 1965)

Most plants make use of carbon to form nitrogen-free structural compounds such as cellulose, whereas animals use many structural materials based upon proteins rather than carbohydrates (Sprent 1987). As a result, typical C:N ratios of leaf tissue of herbaceous angiosperms (10:1) and woody angiosperms (20:1) are higher than those of insects (4:1), fish (5:1) and mammals (7:1) (Reiners 1986). The consequence of an overall high carbon:nitrogen ratio in plant tissue and a high nitrogen demand in animals is a world in which forage for herbivores is abundant, but often nutritionally inadequate with respect to N because of the dilution of N in plant tissue and the limited intake of N per bite. Thus, herbivores frequently exploit transient sources of concentrated nitrogen that occur in plant tissues in either space or time, such as reproductive tissues of plants, which may contain up to 7% N per unit dry weight or growing tissues, newly expanded

leaves or cambial tissues of plants, which contain up to 5% N per unit dry weight (Martin and Kukor 1984).

Unlike plants, which can absorb and incorporate inorganic nitrogen into proteins, animals must obtain nitrogen in the form of organic N (e.g. amino acids, proteins or nucleic acids) present in the tissues of plants, other animals or microorganisms. Although animals synthesize proteins that contain 20 L-amino acids, they are unable to synthesize almost half of these amino acids due to the lack of specific enzymes (Klasing 1998). The amounts and balance of amino acids needed for protein synthesis are rarely matched by those supplied in the diet. When a given essential amino acid limits protein synthesis, all amino acids that are present in excess relative to this limiting amino acid are of no value, except as an energy source, and may even have a negative effect on metabolism (Calvert, Klasing and Austic 1982).

### **1.1.2 Forms of nitrogen available to plants in Arctic ecosystems**

Driven largely by conclusions drawn from agricultural temperate systems, most researchers have assumed that inorganic forms of nitrogen (i.e. nitrate ( $\text{NO}_3^-$ ), and ammonium ( $\text{NH}_4^+$  in northern systems) are the dominant forms of nitrogen taken up by plants (c.f. Giblin *et al.* 1991, Atkin 1996) (Fig. 1.2a). As a result, the majority of studies of ecosystem N dynamics and N uptake by plants at northern latitudes have focused on the dynamics of inorganic N (c.f. Kielland 1994). Inorganic N exists in an extremely wide range of valency states ( $\text{NH}_3$ ,  $\text{NH}_4^+$  (-3),  $\text{N}_2\text{H}_4$  (-2),  $\text{NH}_2\text{OH}$  (-1),  $\text{N}_2$  (0),  $\text{N}_2\text{O}$  (+1),  $\text{NO}$  (+2),  $\text{HNO}_2$ ,  $\text{NO}_2^-$  (+3),  $\text{NO}_2$  (+4),  $\text{HNO}_3$ ,  $\text{NO}_3^-$  (+5)). Biological transformations between many of these inorganic N species are mediated by microorganisms (Spren

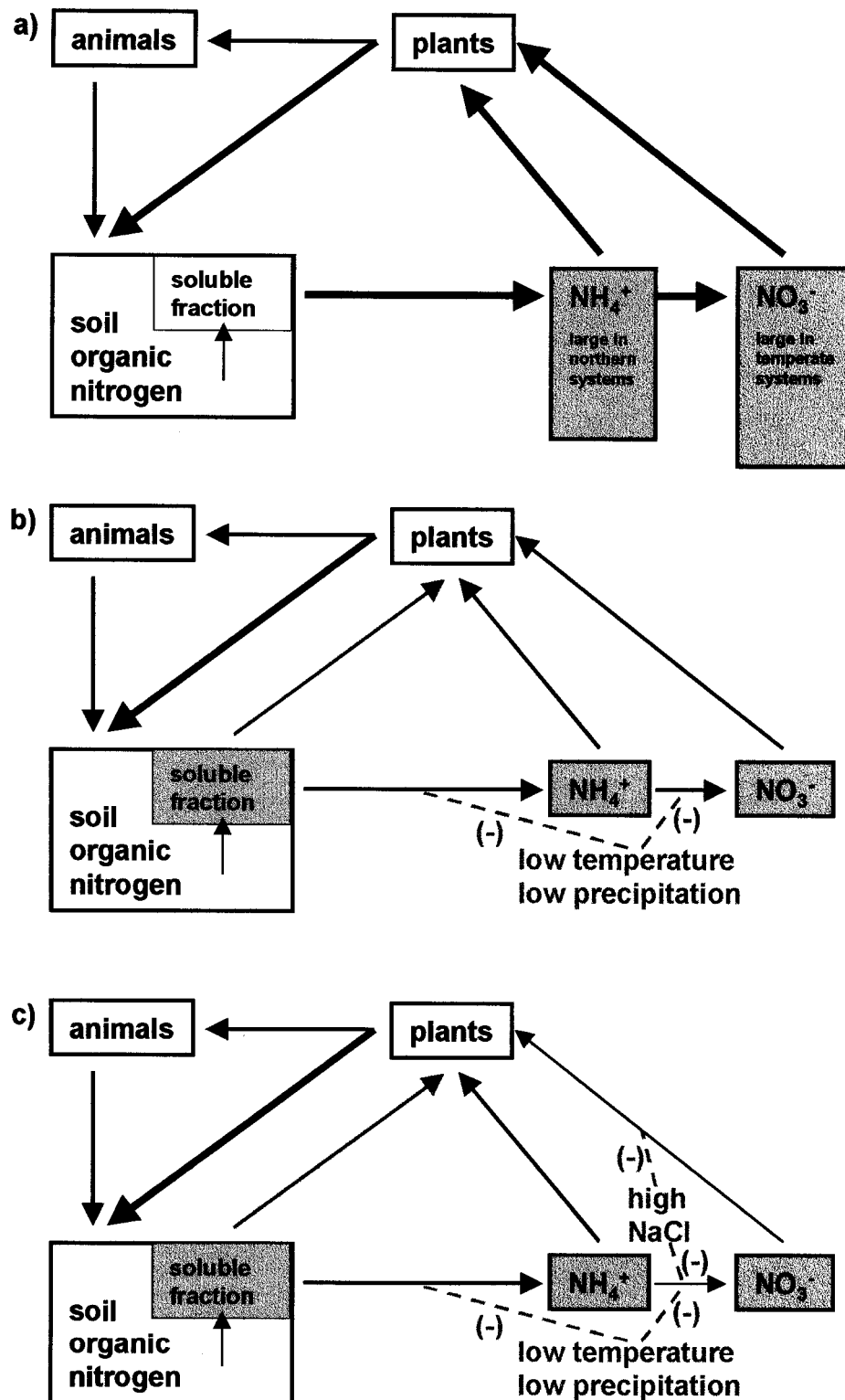

**Fig. 1.2.** a) Traditional model of internal cycling of nitrogen within ecosystems. b) Proposed nitrogen cycling model for Arctic systems (Chapin 1995). c) Proposed nitrogen cycling model for Arctic salt-marsh systems. Pools of nitrogen accessible by plants are shown in gray. Arrow thickness denotes relative flux. Blue dotted lines and (-) indicate strong inhibition of mineralization or plant uptake processes and red highlights plant organic N uptake.

1987). N inputs into Arctic systems are low as a result of low rates of N fixation (Chapin and Bledsoe 1992). When plants rely on inorganic N uptake, primary production is closely linked to the rate at which soil organic N is mineralized to ammonium (and, in some cases, the rate at which it is subsequently oxidized to nitrate) (Chapin 1995). In Arctic systems, inorganic N is in short supply as a result of low mineralization rates ( $0.05\text{-}0.5\text{ g m}^{-2}\text{ yr}^{-1}$ ) relative to those of boreal systems ( $0.9\text{-}6\text{ g m}^{-2}\text{ yr}^{-1}$ ), temperate systems ( $1.1\text{-}20\text{ g m}^{-2}\text{ yr}^{-1}$ ) and tropical systems ( $7\text{-}90\text{ g m}^{-2}\text{ yr}^{-1}$ ) (Nadelhoffer *et al.* 1992). Mineralization rates in Arctic systems are low as a result of the adverse effects of low soil temperatures, frozen soils and a short growing season on soil microbial activity (low precipitation and dry soils may also limit mineralization rates in high Arctic polar desert sites) (Atkin 1996). Much of the inorganic N is present as ammonium because nitrifying bacteria that convert ammonium to nitrate are particularly inactive in cold, water-logged Arctic soils. A further consequence of low microbial activity is the accumulation of organic nitrogen (Nadelhoffer *et al.* 1992). Soil organic N is typically composed of 40% proteinaceous materials, 35% heterocyclic compounds such as nucleic acids, 5% amino sugars and 19% ammonium (Schulten and Schnitzer 1998). A small fraction of proteinaceous materials exist as individual amino acids dissolved in the soil solution (generally referred to as free amino acids). Free amino acids can be absorbed intact by plant roots (Bollard 1959) and rapid, 'high affinity' uptake (c.f. Epstein *et al.* 1963) of amino acids has been demonstrated in a wide range of plants (Lipson and Näsholm 2001). Direct uptake of free amino acids by plant roots has important implications for ecosystem N dynamics, as it may uncouple primary production from

nitrogen mineralization rates in ecosystems where organic N availability is high relative to that of inorganic nitrogen (Fig. 1.2b) (Chapin 1995).

### **1.1.3 The potential role of free amino acids in Arctic coastal marshes**

Nitrogen is generally assumed to be the most limiting nutrient for plant growth in tundra ecosystems (Shaver and Chapin 1986, Nadelhoffer *et al.* 1992), although phosphorus availability may also limit plant growth under some conditions (Nadelhoffer *et al.* 1991). In Arctic salt-marshes, plant growth is N-limited and not phosphorus-limited, except where nitrogen loading is artificially high (Cargill and Jefferies 1984a). The negative effects of a cold climate on inorganic N availability and uptake by salt-marsh plants may be further exacerbated by soil salinity, thus intensifying the importance of amino acids for plant growth in these systems. Detrimental effects of sodium chloride on inorganic N acquisition by plants are both direct and indirect; sodium chloride inhibits nitrification by disrupting the activity of nitrifying bacteria (McClung and Frankenberger 1985, Wilson *et al.* 1999) and chloride ions inhibit nitrate uptake by roots, most likely due to the binding of chloride ions to high-affinity nitrate transporters (chloride ions are of the same charge and shape as nitrate ions) (Cram 1973, Deane-Drummond and Glass 1982, Cerezo *et al.* 1999, Xu *et al.* 2000). Free amino acids may be an important alternative source of nitrogen for plants growing in saline soils, particularly when inorganic N availability is limited (Fig. 1.2c). However, data on amino acid availability in these soils are lacking and the ability of halophytes to grow on amino acids has not been assessed.

In intertidal marshes on the Hudson Bay coast, lesser snow geese (*Chen caerulescens caerulescens* L.) heavily graze the grass, *Puccinellia phryganodes*, (Jefferies 1988a, b). The growth of the vegetation is nitrogen-limited (Cargill and Jefferies 1984a) and addition of goose faecal droppings to swards dominated by *Puccinellia* results in increased standing crop within the growing season (Bazely and Jefferies 1985, Hik and Jefferies 1990). Regrowth of *Puccinellia* swards following defoliation by geese is dependent on droppings, yet estimated amounts of soluble inorganic nitrogen in faeces account for as little as 40% of N sequestered in new plant growth (Hik, Sadul and Jefferies 1991). Free amino acids are a potential source of additional N in faecal material that can be utilized by plants as a source of N.

## 1.2 Soil free amino acids

Bulk soil solution free amino acid concentrations reported for Arctic, alpine and temperate sites range from 1 - 150  $\mu\text{M}$  (Shobert and Komor 1987, Shobert, Kockenberger and Komor 1988, Chapin, Moilanen and Kielland 1993, Raab *et al.* 1996, 1999). Although these concentrations are from 1 - 2 orders of magnitude lower than ammonium or nitrate concentrations present in many temperate, agricultural soils (Shobert and Komor 1987, Shobert *et al.* 1988), free amino acid concentrations are within the range of inorganic nitrogen concentrations in Arctic, alpine and boreal soils (Chapin *et al.* 1993, Raab *et al.* 1996, 1999, Nordin, Högberg and Näsholm 2001, Jones and Kielland 2002). Considerable seasonal variation in free amino acid concentrations is often present, and consistent patterns of seasonal variation are not apparent across sites (Kielland 1995, Raab *et al.* 1999). Aspartate, glutamate and glycine are typically present at the highest

concentrations in the soil solutions, but lysine, alanine, arginine, asparagine, glutamine, histidine, leucine and serine are also well-represented in amino acid profiles at some sites (Abuarghub and Read 1988, Kielland 1995, Raab *et al.* 1996, 1999, Turnbull *et al.* 1996, Schmidt and Stewart 1997, Streeter, Bol and Bardgett 2000).

The soil free amino acid pool is small and dynamic relative to the total soil organic nitrogen pool; reported half-lives for amino acids in soils range from 1.7 - 28.7 h (Hadas *et al.* 1992, Kielland 1995, Jones 1999, Lipson *et al.* 2001, Jones and Kielland 2002), whereas the hydrolysable and non-hydrolysable insoluble fractions of soil organic matter exhibit turnover times of years and hundreds of years, respectively (Paul and Juma 1981). Free amino acids are taken up rapidly by both soil microorganisms and plant roots (Barak *et al.* 1990, Lipson and Monson 1998, Jones and Hodge 1999, Lipson *et al.* 1999, Vinolas, Healy and Jones 2001) and may also be deaminated by extracellular enzymes produced by algae, bacteria and fungi (DeBusk *et al.* 1981, Muñoz-Blanco, Hidalgo-Martínez and Cárdenas 1990).

Physical processes also affect turnover and availability of amino acids within the soil solution (Fig. 1.3) (Jones and Hodge 1999). These processes include movement due to diffusion and mass flow (Nye 1969, Tinker 1969, Jones 1999) fixation to the soil solid phase, metal chelation (Jones 1999) and reaction with sugars and phenols (Iverson and Sowden 1970). The physical behaviour of an amino acid in the soil solution is dependent on its net charge, which is governed by soil pH. At approximately pH 6, the amino groups of amino acids are mostly protonated (pKa 8.7-10.7) and the carboxyl groups are mostly ionized (pKa 1.8-2.5) (Horton *et al.* 1993). Therefore, at pH 6 amino acid skeletons predominately form neutral dipolar zwitterions and they become increasingly

cationic with increasing acidity and increasingly anionic with increasing alkalinity. Seven of the twenty amino acids involved in protein formation also have ionizable side chains. At neutral pH, the side chains of aspartic acid and glutamic acid are negatively charged and the side chains of arginine and lysine are positively charged.

In general, extracellular protease action on necromass is thought to be the greatest contributor to the soil free amino acid pool in Arctic soils (Kielland 1995, Hobbie and Chapin 1996). A model of amino acid transformations in an alpine soil based solely on proteolytic rates and microbial uptake rates was able to predict successfully measured soil amino acid concentrations (Lipson *et al.* 2001). Additional sources of free amino acids are microbial and root cell lysis (Skogland *et al.* 1988), animal and microbial excretory products, root exudates (Schobert, Kockenberg and Komor 1988, Uren 2001), precipitation (Mopper and Zika 1987), runoff and tidal deposition (Fig. 1.3).

### **1.3 Plant amino acid uptake**

#### **1.3.1 Uptake from hydroponic media**

While the ecological relevance of plant amino acid uptake has only been considered in recent years, plant roots have long been known to absorb amino acids (Virtanen and Linkola 1946, Bollard 1959, Miettinen 1959). The uptake of amino acids by plant tissues and cell cultures is typically characterized by complex biphasic or multiphasic kinetics, implicating (but not proving) the presence of multiple amino acid transporters within plant cell membranes (Soldal and Nissen 1978, Reinhold and Kaplan 1984, Schobert and Komor 1987, Li and Bush 1990, 1991, 1992). However, the complementation of yeast transport mutants with *Arabidopsis* cell libraries has enabled

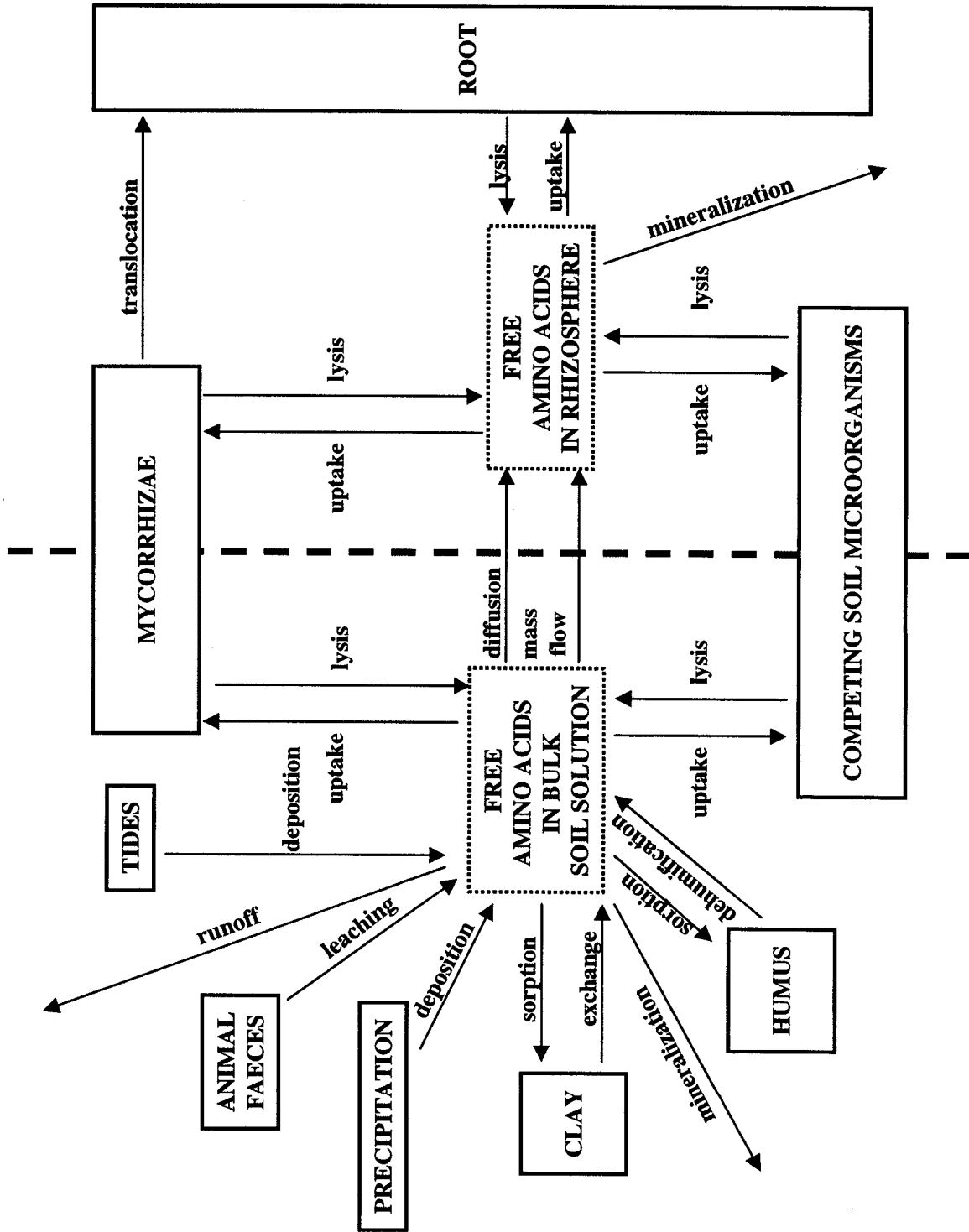

Fig. 1.3. Processes that determine the supply rate of free amino acids to the root surface. The dotted line denotes the division between the bulk soil solution and the rhizosphere.

the isolation of individual plant amino acid transporters (Frommer *et al.* 1993, 1995, Hsu *et al.* 1993, Kwart *et al.* 1993). Competitive inhibition studies on isolated transporters have revealed that plant cell membranes contain both general amino acid transporters, with only partial differences in substrate specificity, and transporters specific to basic amino acids, neutral and acidic amino acids or proline (Fischer *et al.* 1998, Rentsch *et al.* 1998). Although sodium co-transport is common in animals and bacteria, there are no known relatives of animal or bacterial sodium/amino acid co-transporters in plants (Frommer *et al.* 1994). Rather, plant amino acid transporters function as proton symporters (Boorer *et al.* 1996, Boorer and Fischer 1997, Hirner *et al.* 1998). Many amino acid transport genes are expressed in roots (Fischer *et al.* 1998). Nevertheless, their simultaneous expression in other organs indicates that some may be involved in amino acid transport within the plant vascular system, in addition to possible amino acid uptake from soil.

Rapid rates of amino acid uptake from hydroponic solution have been reported for the roots of a wide variety of plants, ranging from Arctic and alpine grasses, sedges and shrubs (Chapin, Moilanen and Kielland 1993, Kielland 1994, Raab, Lipson and Monson 1996, 1999), to boreal grasses, trees and shrubs (Persson and Näsholm 2001), temperate crop plants (Shobert and Komor 1987, Jones and Darrah 1994, Thornton 2001), temperate grasses and forbs (Falkengren-Grerup, Månsson and Olsson 2000) and tropical trees and shrubs (Turnbull *et al.* 1996). Rates of amino acid uptake, both absolute and relative to rates of inorganic nitrogen uptake, can vary by over an order of magnitude across species, even when compared within ecosystems (Kielland 1994, Falkengren-Grerup *et al.* 2000, Persson and Näsholm 2001) or genera (Raab *et al.* 1999). Likewise,

although the uptake of low molecular weight amino acids, particularly glycine, is generally most rapid (Chapin *et al.* 1993, Kielland 1994, Thornton 2001), the relative rates of uptake of different amino acids vary substantially between species (Falkengren-Grerup *et al.* 2000, Persson and Näsholm 2001).

### 1.3.2 Amino acid uptake *in situ*

Dual  $^{13}\text{C}^{15}\text{N}$ -labelled amino acids have been used to evaluate intact amino acid uptake in the field by using measured values of  $^{15}\text{N}$  labelling to calculate the theoretical shift in  $^{13}\text{C}$  corresponding to 100 % uptake as the intact amino acid. Mixed results have been obtained using this technique, with 42 - 91 % of amino acids absorbed intact by boreal grasses, shrubs and trees (Näsholm *et al.* 1998), 82 % by an alpine sedge (Lipson and Monson 1998), 19 - 23 % by temperate agricultural plants (Näsholm, Huss-Danell and Högberg 2000, 2001) and no detectable absorption of intact amino acids by an Arctic sedge (Schimel and Chapin 1996) and by temperate grasses (Hodge *et al.* 1998, 1999). When amino acids are absorbed intact,  $^{13}\text{C}$  taken may be lost through respiration (Schimel and Chapin 1996). Therefore, differences in experimental design and analytical techniques, primarily the incubation time and the position of the labelled carbon, may be responsible for variation in the results of *in situ* uptake experiments (Näsholm and Persson 2001). There is also a large error associated with the high background  $^{13}\text{C}$  content in plant tissue relative to background  $^{15}\text{N}$  (Näsholm and Persson 2001). Nevertheless, variation in results among experiments may genuinely reflect interspecific variation in root uptake or differences in rates of microbial mineralization between sites (Näsholm *et al.* 1998, 2000). In support of the former, it was demonstrated that the

composition of plant communities was related to the partitioning of differentially available forms of organic and inorganic nitrogen among species in an Arctic tundra system (McKane *et al.* 2002).

### **1.3.3 Competition between plants and soil microorganisms**

Although plant roots can absorb amino acids directly, soil heterotrophic microorganisms have generally been considered to be superior competitors for soluble organic nitrogen (Kaye and Hart 1997). Microbial turnover of free amino acids is very rapid (Jones 1999) and the absence of detectable  $^{13}\text{C}$  incorporation in  $^{13}\text{C}^{15}\text{N}$  labelling studies has provided indirect evidence that most free amino acids are mineralized prior to root uptake in at least some systems (Hodge *et al.* 1998, 1999). In *in situ* uptake experiments, plants tend to capture a small fraction (1-6 %) of the added amino acid nitrogen (Lipson and Monson 1998, Lipson *et al.* 1999, Owen and Jones 2001). However, plants are also generally out-competed by microorganisms for inorganic nitrogen (Jackson, Schimel and Firestone 1989, Zak *et al.* 1990, Groffman *et al.* 1993). Furthermore, based on the similarity of plant root and microbial amino acid uptake kinetics, it is predicted that competition between plants and soil microorganisms should be intense, depending on the spatial distribution of roots and microorganisms in the soil (Jones and Hodge 1999, Vinolas, Healey and Jones 2001).

Seasonal fluctuations in microbial biomass and nitrogen availability can influence the relative competitive abilities of plant roots for free amino acids (Lipson, Schmidt and Monson 1999). For example, freeze-thaw cycles may disrupt microbial biomass (Skogland, Lomeland and Goksøyr 1988) and promote a pulse in soluble organic nitrogen

in spring runoff (Ivarson and Sowden 1970, Hobbie and Chapin 1996). However, root amino acid uptake is also disrupted by freeze-thaw cycles and root biomass is low early in the growing season (Lipson and Monson 1998). Therefore, much of this pulse in amino acid nitrogen may be lost from the system. In addition to temporal partitioning of amino acid uptake, the relative competitive abilities of plants and microorganisms can differ substantially among amino acids (Lipson *et al.* 1999).

#### **1.3.4 The role of mycorrhizae**

A major difficulty in the comparison of the relative competitive abilities of roots and microorganisms is that of separating microorganisms forming symbiotic relations with plants from those competing with plants (Näsholm and Persson 2001). Mycorrhizal fungi constitute a large portion of the microbial biomass in soil (Chalot and Brun 1998). Organic nitrogen may be an important source of nitrogen for plants with both ericoid and ectomycorrhizal symbioses (Bajwa and Read 1985, Abuzinadah and Read 1986) and vesicular-arbuscular mycorrhizal associations (Kielland 1994). In some cases, mycorrhizal associations or specialized root adaptations, such as cluster roots, enhance amino acid uptake beyond that of non-mycorrhizal plants (Stribley and Read 1980, Abuzinadah and Read 1989, Bajwa and Read 1985, Turnbull *et al.* 1996, Wallenda and Read 1999). However, the range of affinities of mycorrhizae for amino acids is not much lower than non-mycorrhizal plant roots (Lipson and Näsholm 2001) and many non-mycorrhizal plants take up amino acids rapidly (Chapin *et al.* 1993, Raab *et al.* 1996, Schimel and Chapin 1996). Therefore, the effect of increased absorptive area and proteolytic activity may often be more important than uptake affinity in the improved

acquisition of organic nitrogen as a consequence of mycorrhizal infection (Chalot and Brun 1998).

### **1.3.5 Modelling plant amino acid uptake**

Uptake kinetics and bulk soil solution soluble nitrogen concentrations have been integrated to predict relative rates of amino acid and inorganic nitrogen in the field. Based on these estimates, it has been predicted that amino acids may account for 60% of the total N uptake of the Arctic sedge *Eriophorum vaginatum* (Chapin *et al.* 1993) and between 10 to 82 % of the total N uptake of 10 species of Arctic graminoids and shrubs (Kielland 1994). However, concentrations in bulk soil solution are generally inaccurate estimates of ionic concentrations at the root surface, where depletion zones occur as a result of uptake and microbial demand for nitrogen in the rhizosphere (Nye 1969, Tinker 1969, Jones 1999). A simulation model incorporating soil concentrations, uptake kinetics and ion diffusion rates in the soil predicted that amino acids may account for up to 90 % of the total nitrogen uptake of *Zea mays* at low inorganic nitrogen concentrations and less than 30 % when fertilizer inputs are high (Jones and Darrah 1994). A more sophisticated model was developed for *Eriophorum vaginatum* based on uptake of N into roots, nitrogen supply from microbial mineralization and flux of nitrogen through the soil to the root surface (Leadly, Reynolds and Chapin 1997). The output of this model predicted that supply rate, soil buffering capacity and rates of diffusion are more important than root uptake kinetics in determining rates of uptake in the field. However, accurate modelling of supply rates is difficult given the large number of processes that govern the supply rate of free amino acids to the root surface (Fig. 1.3).

## 1.4 N assimilation

As a result of the high energetic cost of inorganic N assimilation, organic N is potentially a more cost effective N source than inorganic N under conditions where energy is a limiting factor (Schmidt and Stewart 1999). Very high costs are incurred by nitrate assimilation, with 3 ATP equivalents required for the reduction of nitrate to nitrite by nitrate reductase and 9 ATP equivalents required for the subsequent reduction of nitrite to ammonium by nitrite reductase (Pate and Layzell 1990). Ammonium assimilation, executed by the enzymes glutamine synthetase and glutamate synthase, results in the net production of glutamate at a cost of only one ATP and one reductant per ammonium assimilated. However, in ammonium-sensitive species, high energetic costs may result when ammonium is pumped back out of cells after it has entered at unusually high rates (Britto *et al.* 2001).

The cost of free amino acid assimilation is lower than that of inorganic N assimilation because free amino acids can be directly assimilated into proteins in the roots without the need for reductive steps (Pate 1986). Interconversion of amino acids may be required to match the amino acid requirements of protein synthesis and amino acids are generally transported from root to shoot in the form of specific amino acids, such as the amides asparagine and glutamine (and to a lesser extent arginine, glutamate and aspartate) (Lea and Ireland 1999). Interconversion of amino acids often occurs via deamination or transamination, with the resulting keto acid derivative degraded into components which can be used in the Krebs tricarboxylic acid cycle and reincorporated into other amino acids (Beevers 1976). Amino acids are grouped into families based on their derivations from these common biosynthetic precursors (Fig. 1.4) (Buchanan,

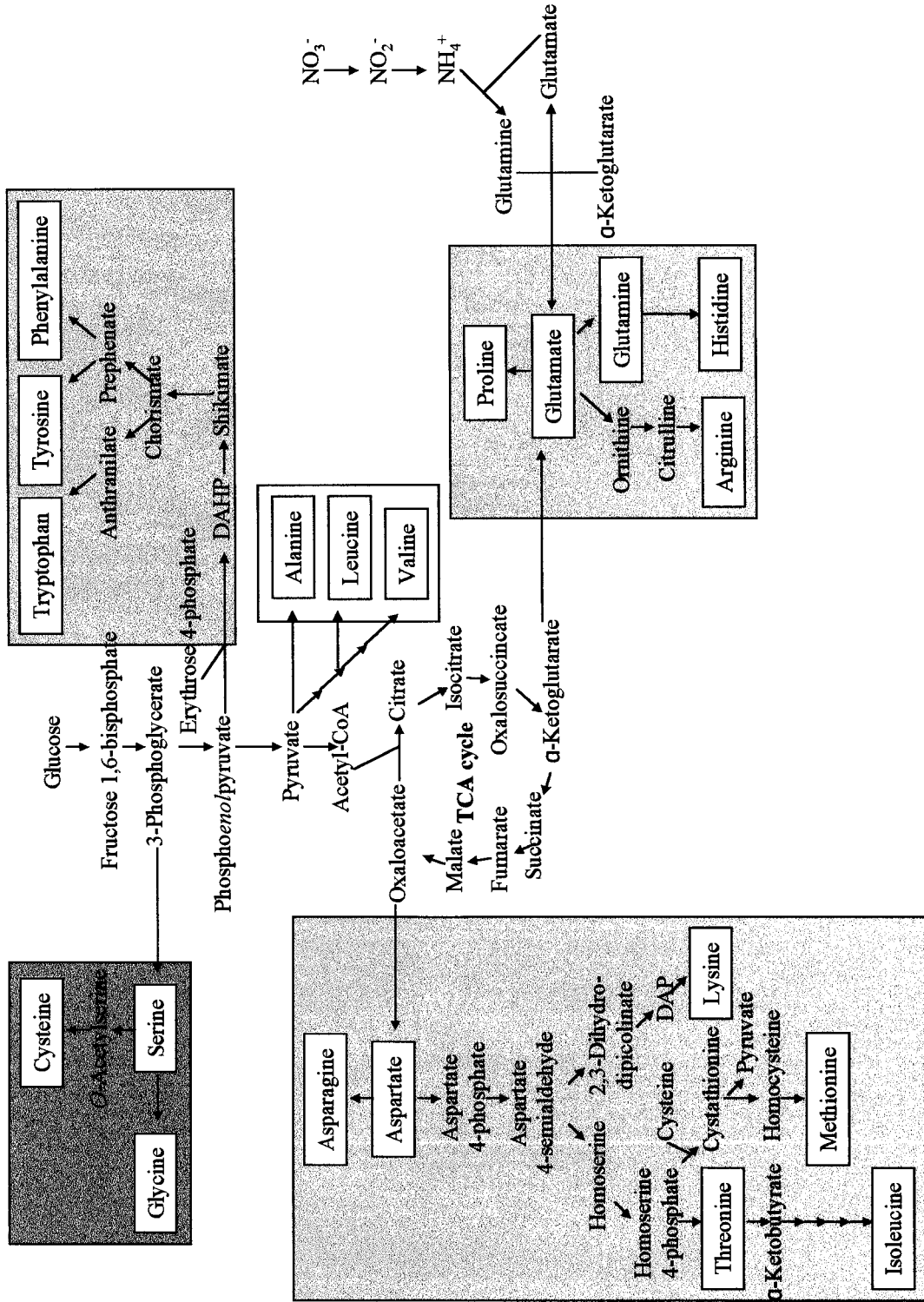

Fig. 1.4. Overview of amino acid biosynthesis in plants (modified from Buchanan, Gruissem and Jones 2000). Amino acids required for protein synthesis are outlined by white boxes and these are grouped by coloured boxes into families based on derivation from common precursors. The pathway for inorganic N assimilation is shown on the right.

Gruissem and Jones 2000). In addition to the low energetic cost of amino acid assimilation, amino acid uptake results in the acquisition of both reduced nitrogen and carbon. For example, Raab *et al.* (1996) demonstrated that glycine contributed 16% of the total carbon assimilation of the alpine sedge *Kobresia myosuroides* under controlled conditions.

### 1.5 Outline of thesis

The primary objective of this thesis was to test the overall hypothesis that the direct uptake of free amino acids contributes to the growth of the dominant Arctic salt-marsh goose forage grass, *Puccinellia phryganodes*. The contribution of free amino acid uptake to net primary production was evaluated in the context of the N dynamics of the entire ecosystem. In order to meet these objectives, a series of sampling protocols, experiments and modelling approaches was performed at numerous scales, ranging from the level of individual plants, to patches of salt-marsh sward, to the entire ecosystem (Fig. 1.5). In Chapter 2, the hypothesis that free amino acids account for a substantial fraction of the soluble N pool in salt-marsh soils was tested by comparing concentrations of free amino acids in soil solutions with those of ammonium and nitrate ions. The hypothesis that *P. phryganodes* can grow on the amino acid glycine as the sole nitrogen source was then tested in the field with the use of a continuous flow hydroponic system to which nutrients were added. In Chapter 3, the hypothesis that *P. phryganodes* can take up free amino acids rapidly over a range of salinities, pH values and temperatures was tested by examining the uptake of <sup>15</sup>N-labelled substrates by excised roots in hydroponic solution. These experiments were used also to test the hypothesis that free amino acids are taken

up rapidly in the presence of ammonium or nitrate ions. In Chapter 4, the hypothesis that free amino acids are taken up intact by *P. phryganodes in situ* was tested by injecting  $^{13}\text{C}^{15}\text{N}$ -glycine tracers into soil cores and monitoring the incorporation of  $^{13}\text{C}$  and  $^{15}\text{N}$  into plant tissue.  $^{15}\text{N}$  tracers were also injected into soil cores to test the hypothesis that *P. phryganodes* competes effectively with soil microorganisms for amino acid N. In Chapter 5, a model of the dynamics of nitrogen movement in an Arctic coastal marsh grazed by lesser snow geese was developed in order to examine the assertion that soluble organic N uptake by plants enhances net annual primary production and the net N incorporation by geese. This model was parameterized using estimates of compartment sizes and rates of N transport between these compartments that were obtained from earlier studies at La Pérouse Bay, MB.

In Chapter 6, results presented in this thesis are synthesized and the potential for free amino acid uptake by *P. phryganodes* in Arctic salt-marsh soils is discussed. In addition, the implications of soluble organic uptake by plants of these salt marshes for the N dynamics of the salt-marsh ecosystem are examined. Key technical limitations that currently hinder the study of amino acids uptake by plants in northern coastal regions are discussed also and directions for future research are proposed.

## I Plant level

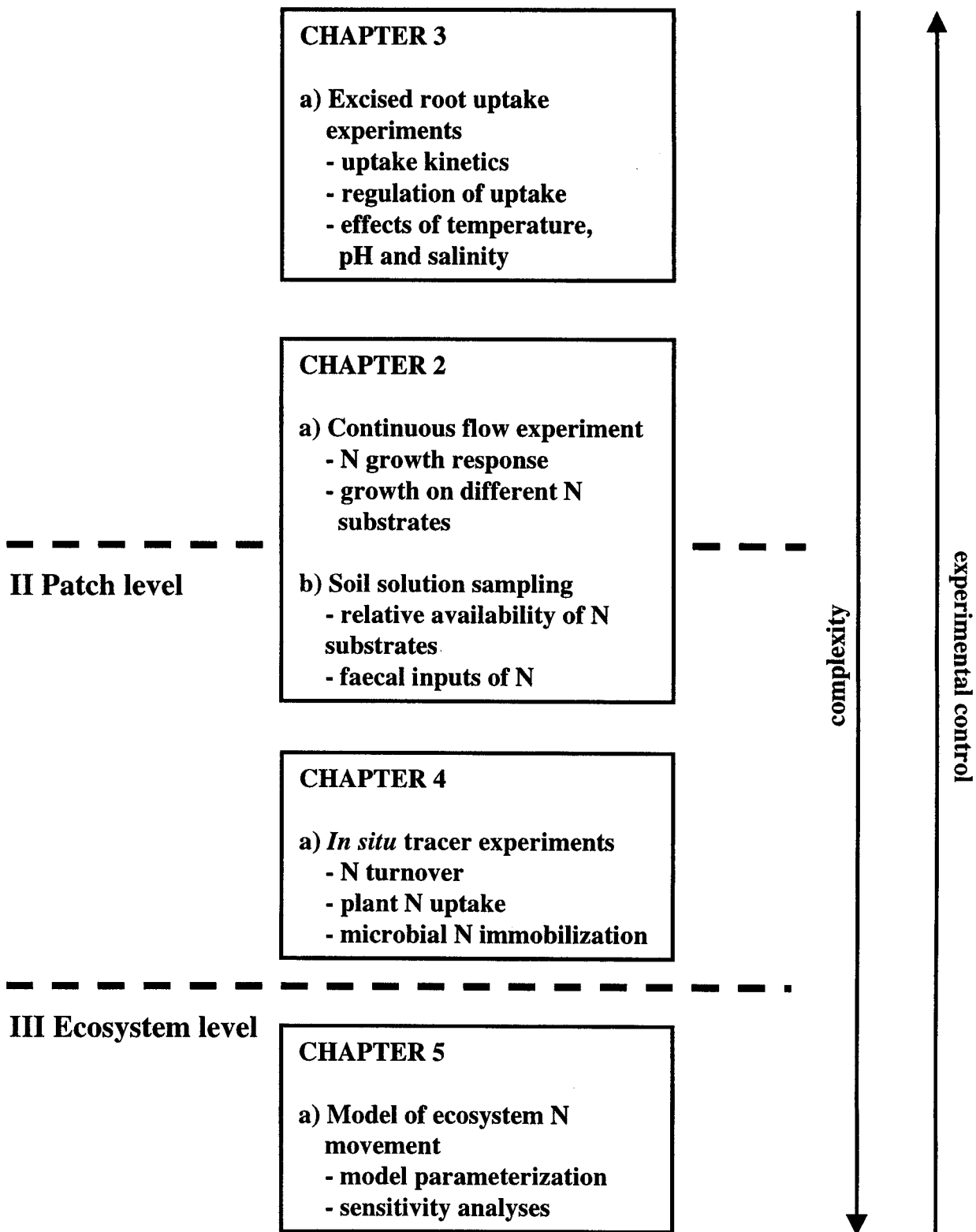

Fig. 1.5. Outline of experimental and modelling approaches presented in the thesis and their associated scales of observation.

## **Chapter 2: Free amino acid, ammonium and nitrate concentrations in soil solutions of a grazed coastal marsh in relation to plant growth**

### **2.1 Abstract**

Soluble free amino acids, ammonium and nitrate ions as sources of nitrogen for plant growth were measured in soils of a coastal marsh grazed by snow geese in Manitoba, Canada. Amounts of nitrogen, primarily ammonium ions, increased in the latter half of the growing season and over winter, but fell to low values early in the growing season. Free amino acid concentrations relative to ammonium concentrations were highest during the period of rapid plant growth in early summer, especially in soils in the intertidal zone, where the median ratio of amino acid nitrogen to ammonium nitrogen was 0.36 and amino acid concentrations exceeded those of ammonium ions in 24% of samples. Amino acid profiles, which were dominated by alanine, proline and glutamic acid, were similar to goose faecal profiles. In a continuous flow hydroponic experiment conducted in the field, growth of the salt-marsh grass, *Puccinellia phryganodes*, on glycine was similar to growth on ammonium ions at an equivalent concentration of nitrogen. When supplies of soil inorganic nitrogen are low, amino acids represent a potentially important source of nitrogen for the regrowth of plants grazed by geese and amino acid uptake may be as high as 57% that of ammonium ions.

## 2.2 Introduction

Although soil inorganic nitrogen (N) is often the primary source of plant N (Glass *et al.* 1999, Murphy *et al.* 2000), soluble organic nitrogen in soils may also be utilized by plants (Lawes and Gilbert 1881). In Arctic and alpine soils, for example, low temperatures, a short growing season and often low precipitation slow rates of N mineralization which results in the accumulation of organic N, including free amino acids which can be readily taken up by plants (Kielland and Chapin 1992, Nadelhoffer *et al.* 1992, Chapin, Moilanen and Kielland 1993, Kielland 1994, Atkin 1996, Raab, Lipson and Monson 1996, 1999). In addition, in some polar soils, these environmental effects on availability and uptake of nitrogen by plants may be further exacerbated by soil salinity. Detrimental effects of sodium chloride on inorganic N acquisition are both direct and indirect; sodium chloride inhibits nitrification (McClung and Frankenberger 1985, Wilson *et al.* 1999) and the presence of chloride ions inhibits nitrate uptake by roots (Cram 1973, Deane-Drummond and Glass 1982, Xu *et al.* 2000). Although free amino acids may be an important alternative source of nitrogen for plants growing in saline soils, particularly when inorganic N availability is limited, data on amino acid availability in these soils are lacking, and the ability of halophytes to grow on amino acids as the sole source of nitrogen has not been assessed.

In the present study, concentrations of free amino acids, ammonium and nitrate ions were determined in soil solutions of an Arctic coastal marsh in which lesser snow geese (*Chen caerulescens caerulescens* L.) heavily graze the dominant grass *Puccinellia phryganodes* that has a diminutive growth form (Jefferies 1988a, b). The growth of the vegetation is nitrogen-limited (Cargill and Jefferies 1984a) and addition of goose faecal

droppings to swards dominated by *Puccinellia* results in increased standing crop within the growing season (Bazely and Jefferies 1985, Hik and Jefferies 1990). Much of the soluble faecal nitrogen is leached from droppings within 48 hours (Bazely and Jefferies 1985, Ruess, Hik and Jefferies 1989). Faecal inputs can be high ( $\leq 175 \text{ g fw m}^{-2} \text{ wk}^{-1}$ ) during the growing season and droppings are widely dispersed (Jefferies and Rockwell 2002). Results from an experimental study indicated that although regrowth of *Puccinellia* swards following defoliation by geese was dependent on droppings, estimated amounts of soluble inorganic nitrogen in faeces were inadequate in some grazing treatments to account for N sequestered in new plant growth (Hik, Sadul and Jefferies 1991). A likely source of additional N in faecal material is the presence of free amino acids. Consequently, we have compared free amino acid profiles in soil and faeces and determined the ability of *Puccinellia* to grow on an amino acid as the sole source of N.

The following questions were addressed: 1. How do seasonal changes in the concentrations of free amino acids in the soil solution compare with those of ammonium and nitrate ions? 2) Are there differences in the N profiles between intertidal sites that are flooded with sea water in late summer and autumn and supratidal sites which are flooded no more than two times every three years? 3. How much temporal and spatial variation in amino acid profiles is present at a site and are the free amino acid profiles of faecal extracts and soil solutions similar? 4. Is the growth response of tillers of *Puccinellia phryganodes* grown in continuous flow hydroponic solutions, in which either glycine or ammonium ions is the sole source of N, similar?

## 2.3 Materials and methods

### 2.3.1 Study sites

The study was conducted in a grazed Arctic coastal salt marsh at La Pérouse Bay, Wapusk National Park, located approximately 30 km east of Churchill, Manitoba, Canada (58° 43 N, 94° 26 W), on the south-west coast of Hudson Bay. The marsh can be subdivided into an intertidal zone, that is tidal in late summer and autumn, but not from snow melt until late July, and a supratidal zone that is rarely flooded with sea water. The vegetation of the intertidal marsh is dominated by *Puccinellia phryganodes* (Trin.) Scribn. and Merr. and *Carex subspathacea* Wormskj, which form discontinuous swards because of early spring grubbing by lesser snow geese that leads to sward destruction (Jefferies 1988a,b). Net above-ground production of intact swards has been estimated to be between 100 and 150 g m<sup>-2</sup> year<sup>-1</sup> (Cargill and Jefferies 1984b, Hik and Jefferies 1990). Further inland, the supratidal zone also is dominated in low-lying areas by swards of *P. phryganodes* and *C. subspathacea*, but low shrubs, predominately *Salix brachycarpa* Nutt., and grasses, especially *Festuca rubra* L. and *Calamagrostis deschampsoides* Trin., colonize frost-heave sites. Nomenclature follows Porsild and Cody (1980).

Soils were classified as Regosolic Static Cryosols (Agriculture Canada Expert Committee on Soil Survey 1987, Wilson and Jefferies 1996). Soils in the intertidal zone have a greyish mineral horizon of marine sediment in which the top 1-2 cm contains organic material. Concentrations of exchangeable ammonium and nitrate ions range from 3.5-8 and 0.2-1 µg N g<sup>-1</sup> soil and soils are often highly reduced ( $E_h$  -50 mV) in spring,

especially where they are close to drainage channels (Wilson and Jefferies 1996). In the supratidal marsh, a mineral base is covered by 3-4 cm of dark brown-black highly humified organic material. Soil pH averages 7.12 +/- 0.04 (n=24) in both the intertidal and supratidal marshes. The salinity of extracted soil solutions can rise to as high as 40 g Na<sup>+</sup>/L in late summer in intertidal sites devoid or nearly devoid of vegetation. However, beneath intact swards the salinity of the bulk soil solution in summer is at or less than that of sea water (c.12 g Na<sup>+</sup> L<sup>-1</sup>) (Srivastava and Jefferies 1995, Wilson and Jefferies 1996).

### 2.3.2 Soil and faecal material sampling

Soils were sampled from rooting zones of intact *Puccinellia* swards at 3 tidal and 3 supratidal sites (>1 km distance between sites) on 9 sampling dates starting 29 May 1999 and ending 30 July 2000 (refer to Fig. 2.1 for sampling dates). On 1 November 1999 and 29 April 2000, only 2 and 5 sites were sampled respectively as other sites were snow or ice-bound. Spring melt occurred in late May or early June and soils froze again in early October. Permafrost was 30-50 cm beneath the surface (Wilson and Jefferies 1996). Within each site, 3 replicate samples (15 cm X 15 cm X 3 cm deep) were collected approximately 50 m apart. Samples were kept cool (3-5 °C) and extracted within 24 hours by hand squeezing (and by centrifugation on 1 July and 21 July 1999). Results from squeezing were compared with those based on water extraction using a ceramic cup tensiometer (model 1905, Soil Moisture Equipment Corp., Goleta, CA) and data sets were similar for concentrations of individual amino acids ( $r^2=0.95$ ). However, ammonium ions concentrations in tensiometer samples were approximately one-tenth of those in samples collected by squeezing. Raber *et al.* (1998) have shown centrifugation

is a suitable method for obtaining soil solutions. Fresh goose faeces (n=6) were collected from both intertidal and supratidal marshes on 30 June and 21 July 1999 and extracted in 60% ethanol (15 g f.w. in 75 mL) for 6 h. For all analyses, latex gloves were worn and glassware was acid-washed to minimize contamination. Appropriate blanks and standards were used for all analyses to correct for potential contamination and deionized water washings from gloves yielded no amino acid contamination. Extracts were filtered through Whatman GF/A glass filter paper and frozen at -20 °C until analysis.

### **2.3.3 Soluble nitrogen analyses**

Free amino acids in soil solutions and faecal extracts were separated by reverse-phase HPLC through 2 Waters PICO-TAG columns (3.9 mm X 300 mm; packing material 3 µm NOVAPAK) at a temperature of 46 °C, following the method of Bidlingmeyer *et al.* (1987). Samples were pre-column derivatized using a methanol-water-triethylamine-phenylisothiocyanate (7:1:1:1) reagent to form phenylthiocarbamyl derivatives of the amino acids, eluted with a Waters PICO-TAG gradient and fluorescence was measured at 254 nm.

Ammonium and nitrate (as nitrite) concentrations were determined colorimetrically following reaction with phenol-sodium nitroprusside (Solorzano 1969) and Marshall's reagent respectively using an auto analyser (Pulse Instrumentation Ltd., Saskatoon, Saskatchewan). Nitrate was reduced to nitrite prior to analysis (Keeney and Nelson 1982). Total soluble nitrogen was measured for pooled samples at a site, on each sampling date, using alkaline persulfate oxidation (Cabrera and Beare 1993), followed by analysis for nitrate (as nitrite). By subtracting ammonium, nitrate and total free amino

acid concentrations from the total nitrogen concentration, an estimate of the concentration of unidentified soluble nitrogen sources was obtained. The fraction of unidentified soluble nitrogen that comprised of proteins and peptides was estimated for a small subset of samples (n=3) by evaporating and hydrolysing aliquots of samples prior to HPLC analysis.

#### **2.3.4 Continuous flow experiment**

A continuous flow hydroponic experiment was assembled under field conditions in an experimental garden in the supratidal marsh at La Pérouse Bay. Plant material was collected from a single patch to minimize genetic variation. Individual tillers (shoots approx. 2.5 cm long and roots approx. 5 cm long) of *P. phryganodes*, that had only actively growing white roots produced within the season, were placed in 250 mL culture vessels sunk into the ground. The roots were bathed in one-tenth strength N-free Hoagland's solution containing 50 mM NaCl to which was added the appropriate nitrogen source to give final concentrations of either 10, 100 or 1000  $\mu\text{M}$  of ammonium or 100  $\mu\text{M}$  of glycine. Solutions were gravity-fed from 45 L polypropylene reservoirs into sets of 6 culture vessels, drained into 40 L reservoirs sunk into the ground and fed back to the 45 L reservoirs via Rio 180 powerhead pumps (TAAM Inc., Camarillo, CA). Solutions in the reservoirs were well agitated and the flow rate into culture vessels of 350  $\text{mL min}^{-1}$  ensured that the solutions were replaced every 45 s. Reservoirs and culture vessels were connected via Tygon 80-H tubing and culture vessels were positioned randomly within three blocks. Solutions were changed every second day to avoid bacterial growth and to ensure a nitrogen depletion of < 5%, and light was excluded from

culture vessels, reservoirs and tubing to stop algal growth. Solutions remained clear at all times and examination of roots under a light microscope showed no accumulation of slime on roots and no evidence of the build-up of bacterial plaque on the root surface under high magnification (X 600).

Tillers were transplanted on 22 June 2000 soon after melt and plants were harvested on 5 July, 20 July and 4 August (6 replicates per nutrient treatment per harvest). Root and shoot material was washed in deionized water, dried at 60 °C for 4 days and then weighed and ground. Nitrogen content was determined using Kjeldahl digestion followed by analysis for ammonium concentrations as indicated above.

Sub-samples of root material were collected and preserved in 60% ethanol for estimations of root surface area in order to calculate net nitrogen fluxes into roots during the experiment. Root surface area was estimated by measuring length and diameter of primary and secondary roots and roots hairs under a light microscope. For diameter measurements, roots were immersed in glycerin and diameter, root hair length and number were quantified for 0.4 mm long segments at 3 mm intervals along the root length (n=2 tillers per treatment per sampling date).

In a separate study, transpiration rates were determined in order to assess whether mass flow alone to the root surface could account for the estimated net fluxes of N. Water loss from sealed culture vessels with tillers was measured over 24 hrs and measurements were made four times during the season using six replicates at a range of air temperatures and light conditions. Leaf surface area was estimated in a similar manner as root surface area based on leaf length and incremental diameter measurements.

### 2.3.5 Data analyses

Mean free amino acid, ammonium and nitrate concentrations were compared between the intertidal and supratidal marshes on each sampling date using a Tukey HSD multiple comparisons test. This test is an exact alpha-level test when sample sizes are equal (Tukey 1953).

For the continuous flow experiment, mean responses and standard errors for all treatments at each harvest date were estimated and plotted. Full factorial ANOVA models were used to test for significant differences between harvest dates and treatments for plant dry weight, N content of plants as a percentage of dry weight (both log-transformed) and the root:shoot ratio. Within harvest dates, treatment differences were assessed using pairwise t-tests. In all cases, blocks were pooled due to a lack of significance of block effects ( $p > 0.75$ ).

For each treatment, regression lines were fitted to log-linear plots of estimated root surface area and cumulative total N uptake over time. Regression equations were used to estimate the daily flux of N per unit of root surface. Estimates of daily N uptake were used to calculate the rate of transpiration required to supply sufficient N to the root surface only via mass flow assuming steady-state conditions (Tinker 1969). These rates of transpiration were also expressed as the required transpiration rate per unit leaf area, in order to meet the estimated net N influx and compared with measured transpiration rates.

## 2.4 Results

### 2.4.1 Temporal and spatial trends in soluble N

For both intertidal and supratidal sites, concentrations of soluble N were relatively low at the beginning of the growing season after snow had melted. They increased later in the growing season (late July in both 1999 and 2000) and over the winter, and fell back to low values at the beginning of the following growing season (Fig. 2.1). The seasonal trends in concentrations of soluble N were determined largely by the presence of ammonium ions, which, on average, were the dominant form of soluble nitrogen (Fig. 2.2). Although total free amino acid concentrations rose over the winter in the intertidal zone and declined in the supratidal zone, seasonal trends in free amino acids (and nitrate concentrations) were less pronounced than those of ammonium ions.

The proportion of total free amino acids relative to inorganic nitrogen was highest during the growing season, when ammonium concentrations were at their lowest (Fig. 2.2). This proportion was also highest for intertidal sites, where ammonium and total free amino acid concentrations ranged from 53-203  $\mu\text{M N}$  and 25-47  $\mu\text{M N}$  respectively (nitrate concentrations ranged between 8-37  $\mu\text{M N}$ ) and the median proportion of total amino acids to ammonium was 0.36 throughout the growing season. Due to both high spatial heterogeneity and a lack of dependence between ammonium and total amino acid concentrations, this ratio varied widely between samples (Fig. 2.3). As a result, amino acids were present at concentrations greater than

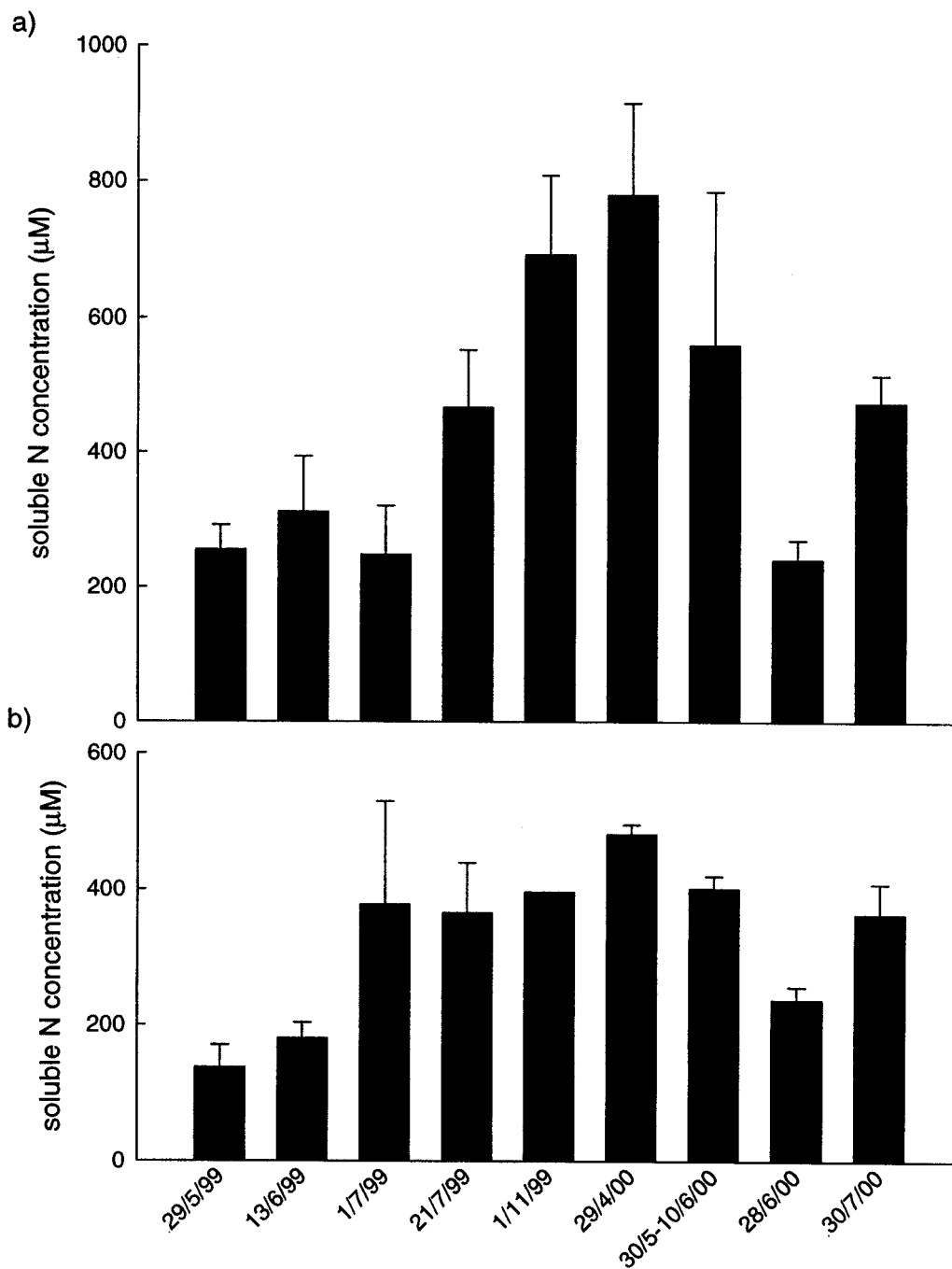

Fig. 2.1. Seasonal trends in persulfate oxidation estimates of total soluble nitrogen in soil solution samples collected from a) the intertidal zone and b) the supratidal zone of a salt-marsh at La Pérouse Bay, Manitoba, over 14 months. Each bar represents the mean of three sites (3 replicates chemically pooled per site) and lines denote standard error.

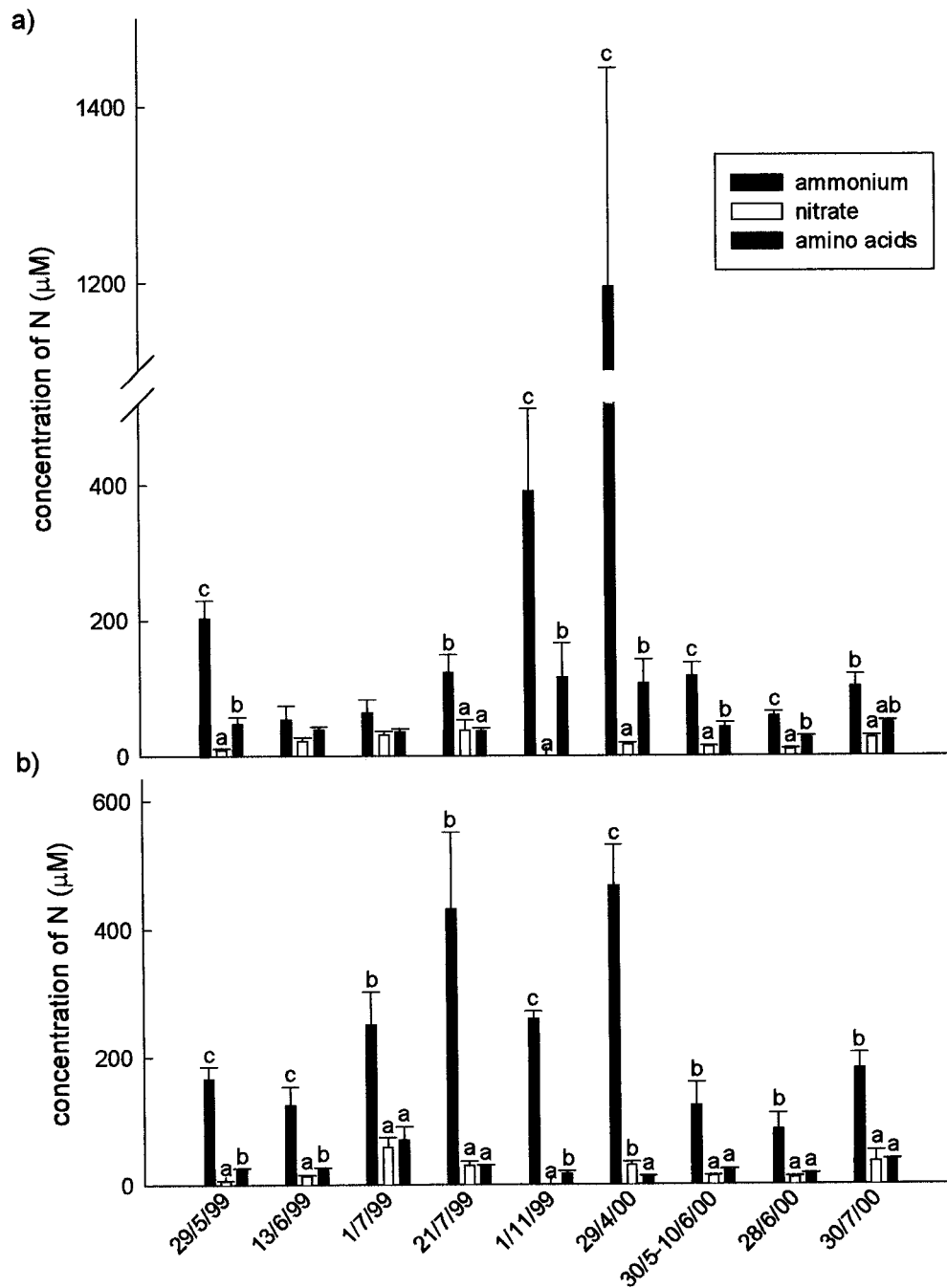

Fig. 2.2. Seasonal trends in free amino acids, ammonium and nitrate concentrations in soil solution samples collected from a) the intertidal zone and b) the supratidal zone of a salt-marsh at La Pérouse Bay, Manitoba, over 14 months. Each bar represents the mean of 3 sites (3 replicates per site) and lines above the bars denote standard error. Common lower case letters denote a lack of a significant difference between soluble nitrogen species within a given sampling date (Tukey's HSD test).

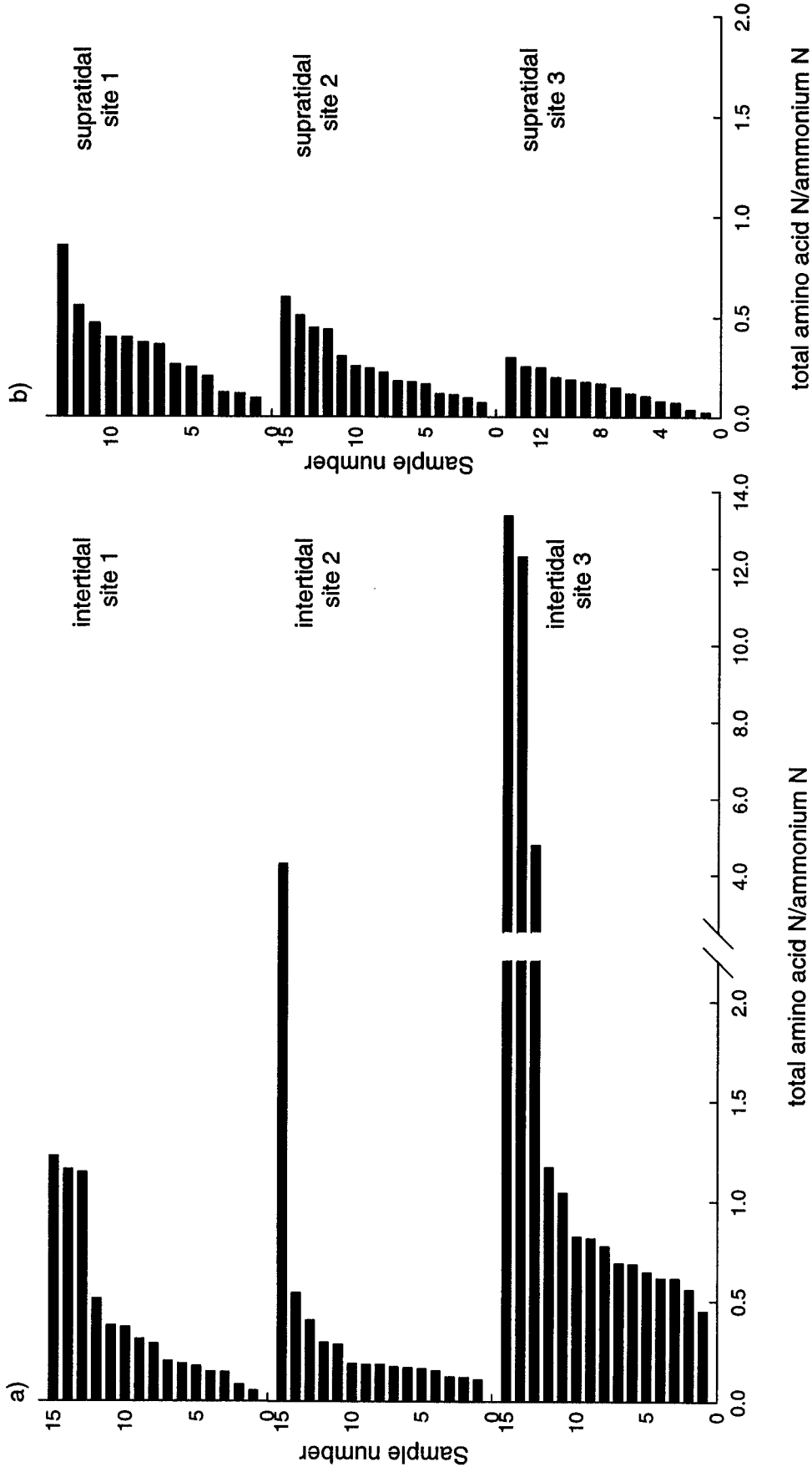

Fig. 2.3. Distribution of total free amino acid nitrogen as a proportion of ammonium nitrogen in soil solution samples collected during the growing seasons of 1999 and 2000. Samples are grouped and ordered within sites in a) the intertidal zone and b) the supratidal zone of a salt-marsh at La Pérouse Bay, Manitoba.

those of ammonium ions in 24% of soil extracts sampled from intertidal sites during the growing season.

Mean concentrations of unidentified soluble nitrogen compounds were higher in intertidal sites ( $188 \pm 37 \mu\text{M}$  nitrogen,  $n=25$ ) than in supratidal sites ( $77 \pm 19 \mu\text{M}$  nitrogen,  $n=25$ ), where they accounted for 42% and 24% of the total soluble nitrogen pools respectively. From 52% to 98% of unidentified soluble nitrogen compounds were proteins and peptides. For both intertidal and supratidal sites, concentrations of unidentified soluble nitrogen compounds were highest during spring melt (May 30-June 10, 2000; spring melt soil water was not sampled in 1999, as melt occurred in April before our arrival).

Soil amino acid profiles were dominated by alanine and to a lesser extent proline and glutamic acid (Fig. 2.4). Other amino acids present at relatively high concentrations included gamma-aminobutyric acid (gaba) and valine, that were prevalent in intertidal sites, and leucine, lysine and tyrosine, which were present at all sites. Lysine concentrations were highly correlated with air temperature; they were high throughout the growing season and low in winter in both intertidal and supratidal sites (Fig. 2.4). In the intertidal marsh, other amino acids, such as valine and glycine, showed the opposite trend and high concentrations were present at low temperatures. However, these increases were not proportional increases, as the total amino acid pool also increased at this time. The free amino acid profile of faecal matter extracts collected in 1999 closely resembled that of soil solution collected over the same period (Fig. 2.5). Concentrations of individual amino acids expressed as a proportion of total amino acid concentration were statistically indistinguishable between faecal extracts and soil solutions for 16 of the

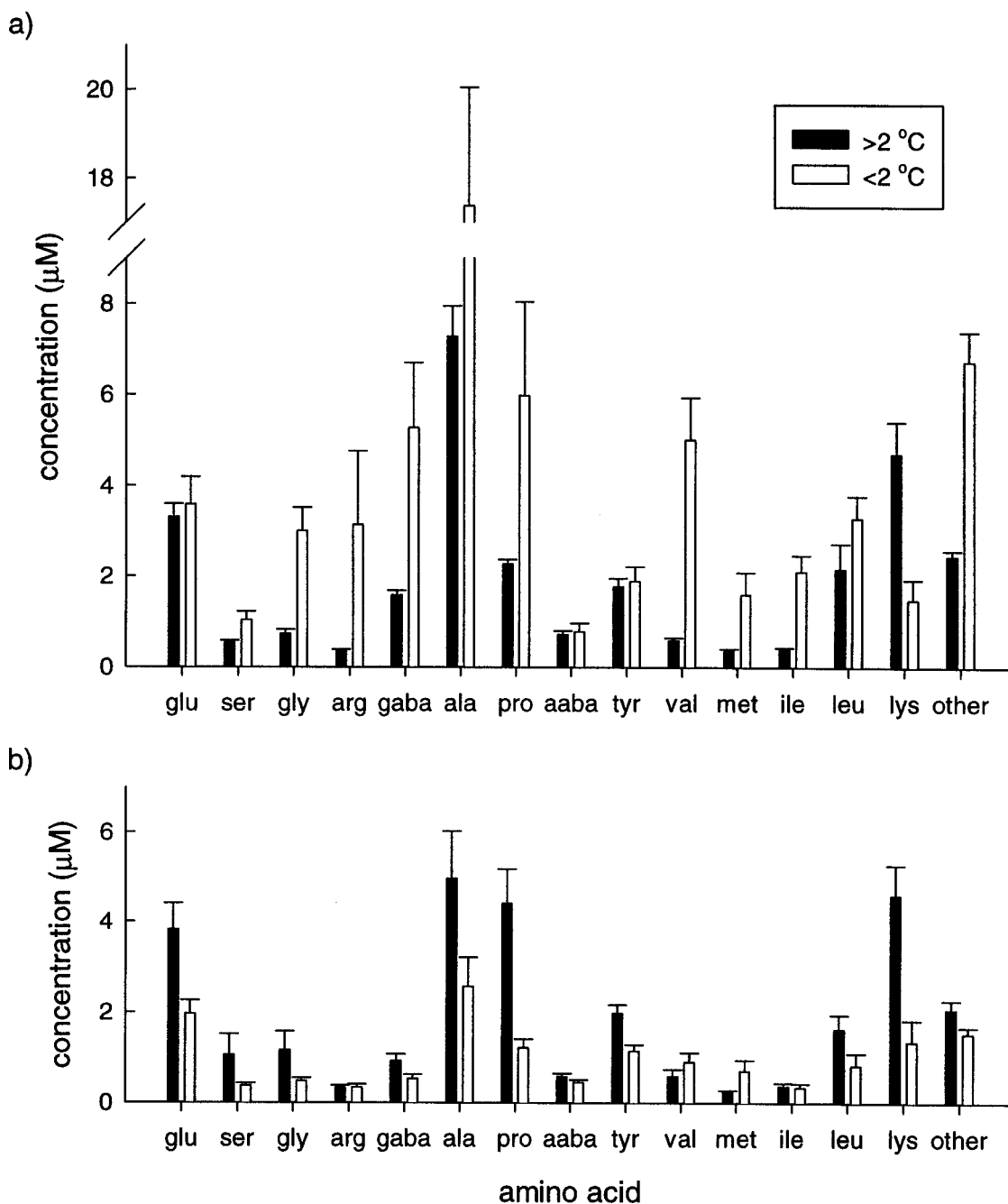

Fig. 2.4. Mean concentrations of amino acids present in bulk soil solutions of a) the intertidal zone and b) the supratidal zone of a salt-marsh at La Pérouse Bay, Manitoba. Data are pooled for sampling dates where the mean soil temperature was greater than  $2\text{ }^{\circ}\text{C}$  (black bars: 13 June, 1 July, 21 July 1999 and 28 June, 30 July 2000) and less than  $2\text{ }^{\circ}\text{C}$  (white bars: 29 May, 1 November 1999 and 29 April, 6 June 2000). Amino acid key: asp=aspartic acid, glu=glutamic acid, asn=asparagine, ser=serine, gln=glutamine, gly=glycine, his=histidine, arg=arginine, gaba=gamma-aminobutyric acid, thr=threonine, ala=alanine, pro=proline, aaba=alpha-aminobutyric acid, tyr=tyrosine, val=valine, met=methionine, cys=cysteine, ile=isoleucine, leu=leucine, phe=phenylalanine, try=tryptophan, lys=lysine.

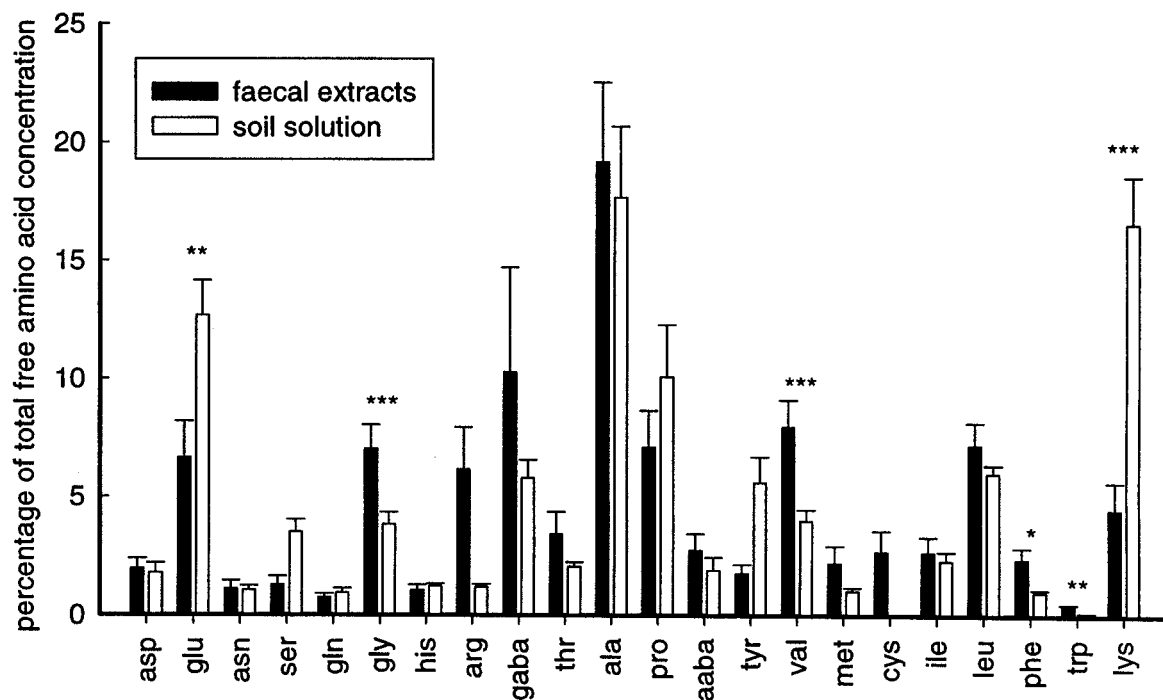

Fig. 2.5. Mean concentrations of amino acids present in faecal extracts (black bars) and bulk soil solution (white bars) expressed as a percentage of the total free amino acid concentration for samples collected on 30 June and 21 July 1999. Error bars denote standard error. Significant differences between faecal extract and soil solution percentages as determined using pairwise t-tests denoted as follows: \*  $p < 0.05$ , \*\*  $p < 0.01$  and \*\*\*  $p < 0.001$ . Refer to Fig. 2.4 for amino acid key.

22 amino acids tested, although concentrations did differ significantly between soil and faeces for glutamic acid, glycine, lysine, phenylalanine, tryptophan and valine (Fig. 2.5).

#### **2.4.2 Continuous flow uptake experiment**

At the final harvest, biomass of *P. phryganodes* tillers grown in a solution of 100  $\mu\text{M}$  glycine was comparable to the biomass of tillers grown at an equivalent ammonium concentration (Fig. 2.6a). In response to a higher ammonium concentration, tillers increased biomass production and nitrogen uptake, although total nitrogen uptake per plant at the final harvest appeared to saturate between external ammonium concentrations of 100 and 250  $\mu\text{M}$  (Fig. 2.6b). Total nitrogen uptake per plant was comparable for tillers grown on both 100  $\mu\text{M}$  glycine and ammonium (Fig. 2.6b). Tissue N as a percentage of dry weight increased until day 28 then levelled off between days 28 and 43 for all ammonium treatments. It continued to increase for the glycine treatment, which reached the same percent N values by day 43 as those in tissues of plants grown at the two highest ammonium treatments (Fig. 2.6c). Root:shoot ratios decreased sharply between days 28 and 43 for all treatments with the exception of the 10  $\mu\text{M}$  ammonium treatment, where the root:shoot ratio remained high (Fig. 2.6d). From the results of the continuous flow experiment, we can estimate that soil amino acids contribute up to 57% of the nitrogen taken up by swards of *Puccinellia* in the intertidal zone during the snow-free season relative to ammonium N. This estimate is obtained by calculating the total uptake of ammonium and glycine N per tiller over 43 days as a function of the external concentrations of N (Fig. 2.6b). A constant proportion of glycine uptake relative to

**Fig. 2.6.** Plots of a) total dry weight versus day, b) total nitrogen at final harvest versus N concentration in the growth solution, c) whole plant %N versus day and d) root:shoot ratio versus day for individual tillers of *Puccinellia phryganodes* grown in hydroponic culture at fixed nitrogen concentrations in the field at La Pérouse Bay, Manitoba, from 22 June to 4 August 2000. Error bars denote standard error (n=6). Full factorial ANOVA results are as follows: a) total dry weight - day (F=210, p<0.001), treatment (F=2.86, p=0.044), day\*treatment (F=2.00, p=0.124), c) %N - day (F=33.9, p<0.001), treatment (F=8.55, p<0.001), day\*treatment (F=0.51, p=0.678), d) root:shoot - day (F=11.85, p=0.001), treatment (F=3.44, p=0.022), day\*treatment (F=3.24, p=0.028). Lower case letters denote treatment differences within sampling dates as determined using pairwise t-tests. Curve fitted to data for total N uptake versus N concentration in b) was obtained using OLS regression: total N uptake =  $0.347 + 2.87(1 - e^{-0.0178 \text{concentration}})$ .

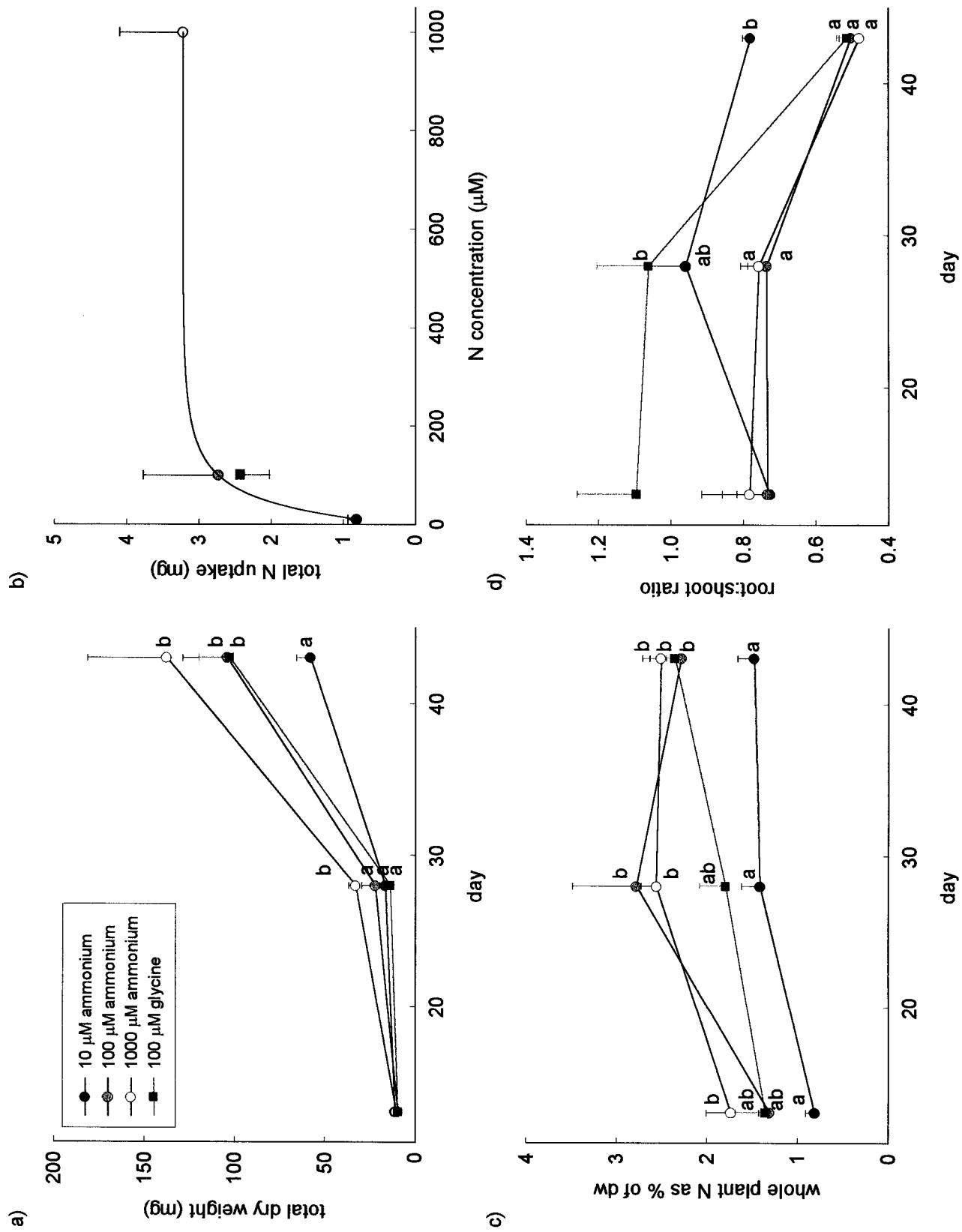

ammonium uptake was assumed over all concentrations based on the proportion at 100  $\mu\text{M}$ . Values of N uptake were adjusted to reflect uptake expected when the concentrations of these N sources in the bulk soil solution were expressed as mean values for the growing season (ammonium: 103  $\mu\text{M}$ , amino acids: 39  $\mu\text{M}$ ). Mean nitrate concentrations in intertidal soils were low (20  $\mu\text{M}$ ) and nitrate uptake was not estimated as the growth response to nitrate was not determined experimentally.

Estimates of the mean net nitrogen flux across the root surface necessary to sustain mean tissue concentrations ranged between 0.17 and 1.26  $\mu\text{mol cm}^{-2} \text{d}^{-1}$  for plants in the solutions of 10 and 1000  $\mu\text{M}$  ammonium chloride respectively (Table 2.1). Estimated mean rates of transpiration from leaves required to supply sufficient nitrogen to the root surface solely as a result of mass flow were 14 and 0.20  $\text{H}_2\text{O cm}^{-2} \text{d}^{-1}$  respectively for these plants (Table 2.1). These values greatly exceeded the observed transpiration rates in the field, which ranged from 0.005 to 0.04  $\text{g H}_2\text{O cm}^{-2} \text{d}^{-1}$ , indicating that diffusion as well as mass flow influences the nitrogen supply rate to the root surface.

**Table 2.1.** Range of estimates for daily nitrogen flux across root surface and transpirational flow required to maintain a constant net supply of nitrogen to the root surface via mass flow for tillers of *P. phryganodes* grown in hydroponic culture.

daily nitrogen flux ( $\mu\text{moles N cm}^{-2} \text{d}^{-1}$ )			
10 $\mu\text{M NH}_4\text{Cl}$	100 $\mu\text{M NH}_4\text{Cl}$	1000 $\mu\text{M NH}_4\text{Cl}$	100 $\mu\text{M glycine}$
0.17-0.58	0.62-1.05	0.49-1.26	0.45-0.87
required transpirational flow ( $\text{g H}_2\text{O cm}^{-2} \text{d}^{-1}$ )			
10 $\mu\text{M NH}_4\text{Cl}$	100 $\mu\text{M NH}_4\text{Cl}$	1000 $\mu\text{M NH}_4\text{Cl}$	100 $\mu\text{M glycine}$
7.6-14.0	1.6-2.9	0.20-0.22	1.9-2.4

## 2.5 Discussion

### 2.5.1 Temporal and spatial trends in soluble N

Despite seasonal and between-site variation in free amino acid concentrations in soils, the size of the soluble N pool was determined primarily by changes in the concentration of ammonium ions, the dominant form of soluble N. Nitrate concentrations were particularly low as a percentage of total soluble N (Fig. 2.2). However, during much of the early and mid-growing season when there was a rapid increase in standing crop, ammonium concentrations in soil solutions were also low. Free amino acids contributed most to the soluble nitrogen pool at this time, especially in intertidal sites, where N present in amino acids exceeded  $\text{NH}_4^+\text{-N}$  in nearly a quarter of samples collected during the growing season (Fig. 2.3). Tillers may exploit soil patches rich in amino acids in order to meet the N demand for growth following defoliation by geese. The degree to which this occurs is dependent on both the extent of amino acid rich patches and the ability of plant roots to exploit these microsites (Hodge *et al.* 2000). Although the relative contribution of free amino acids to the soluble N pool is lower than that found in other Arctic sites (Chapin *et al.* 1993, Kielland 1995), where free amino acids exceed inorganic N by an order of magnitude, the results are comparable to those reported for alpine sites (Raab, Lipson and Monson 1996,1999), and they far exceed the relative contribution of free amino acids to the N pool in temperate or subtropical soils (Shobert and Komor 1987, Shobert, Kockenberger and Komor 1988, Turnbull *et al.* 1996). In Arctic soils where free amino acids exceed soluble ammonium ions by an order of magnitude, enhanced extracellular protease activity at low soil pH may be responsible for the high levels (Kielland 1995).

In both intertidal and supratidal sites, soluble N concentrations rose during late summer and in winter (Fig. 2.1). Increases in soluble N in winter may be linked to freeze-thaw events (16 per year, on average, in the Churchill area, c.f. R. Bello, unpublished data) and brought about by the lysis of bacterial and root cells (Skogland *et al.* 1988, Hobbie and Chapin 1996), and leaching of soluble nitrogen from senescent leaves (Kielland 1995). This build-up of soluble N is responsible for the pulse of nitrogen present in spring melt water, much of which may be lost as runoff since plant uptake is low due to low root biomass, cold temperatures and frozen conditions immediately below the soil surface (Hobbie and Chapin 1996, Brooks *et al.* 1998). In both supratidal and intertidal sites, spring melt was characterized by relatively high concentrations of unidentified soluble N compounds (comparison of Figs 2.1 and 2.2), that is consistent with cell lysis and litter breakdown associated with freeze-thaw cycles. Although this assertion may appear to be contradicted by the fact that the high  $\text{NH}_4^+$ -N concentrations of frozen samples from the intertidal zone in late April, 2000 exceeded the estimated total soluble nitrogen, the estimate may have been biased by high concentrations of dissolved organic carbon, which can compete with soluble nitrogen for oxygen during the persulfate reaction (Cabrera and Beare 1993). Ammonia volatilization may also result in incomplete N recoveries from solutions containing high initial concentrations of ammonium ions when alkaline oxidation is employed (Ross 1992). From 52% to 98% of unidentified soluble N compounds were proteins or peptides. Since small peptides can be taken up by plant roots (Stribley and Read 1980), this pool of nitrogen may represent a further source of organic N for coastal plants, beyond that measured in this study. Based on the findings of Lee (1988), it is likely that amines (and

urea) are also an important component of the remaining unidentified nitrogen compounds. However, aside from samples collected in April 2000, soluble inorganic nitrogen and free amino acids accounted for the majority of the total soluble nitrogen (58-76%).

In contrast to intertidal sites, where amino acids concentrations rose over the winter, amino acid concentrations declined in soils in the supratidal marsh (Fig. 2.2). This disparity between supratidal and intertidal sites may be related to differences in snowpack and ice cover, which influence soluble nitrogen concentrations due to their effects on soil temperature and water availability (Brooks *et al.* 1998). In intertidal sites, a thick layer of ice (30 cm) was present in winter and early spring, under which soils were both frozen and highly anoxic. Freeze-thaw cycles of a few days do not lead to the disappearance of this ice layer. In supratidal sites, in contrast, where snow was frequently blown elsewhere exposing the soil surface and highly reduced conditions were not present, mineralization rates may have been higher, especially during freeze-thaw cycles, leading to a decline in free amino acid concentrations. Breakdown and decomposition of litter can occur beneath snowpacks in winter during freeze-thaw cycles (Hobbie and Chapin 1996).

### **2.5.2 Amino acid profiles**

The free amino acid profiles of soils are generally more similar to those of bacteria than to those of algae, fungi and yeasts (Block 1956, Sowden, Chen and Schnitzer 1977). In addition, in salt-marsh soils, high concentrations of proline are likely the result of fine root and microbial cell lysis, as proline is used as an osmoregulatory

solute in *Puccinellia* species (Stewart and Lee 1974) and in microorganisms (Flowers *et al.* 1977). Lysine, which was present at high concentrations in both marshes at warmer temperatures does not normally occur at high concentrations in plant tissue, suggesting that its origin also may be a product of microbial decomposition.

The free amino acid profiles of both supratidal and intertidal sites during the growing season showed marked differences from those reported for other Arctic and alpine sites (Chapin *et al.* 1993, Kielland 1995, Raab *et al.* 1996, 1999). Although different Arctic communities have been shown to exhibit unique amino acid profiles (Kielland 1995), typically, the dominant amino acids reported in Arctic sites have been glycine, serine and glutamic acid, with asparagine, arginine, aspartic acid, alanine and cysteine present at high concentrations at some sites. While glutamic acid concentrations were moderately high in both supratidal and intertidal soils and glycine and serine reached occasional high concentrations in supratidal sites, salt-marsh soils were dominated primarily by alanine, proline, lysine and leucine (Fig. 2.4). Alanine and gamma amino-butyric acid may be microbial decarboxylation products of aspartic and glutamic acids respectively, and the high levels of glycine and serine may have originated from mats of diatoms present on these salt-marsh soils (Lee 1988).

### **2.5.3 Continuous flow experiment**

The comparable biomass at final harvest of tillers grown on equivalent concentrations of ammonium ions and glycine indicates the ability of *P. phryganodes* to utilize this amino acid as the sole source of nitrogen (Fig. 2.6a). From this result, we can estimate that amino acid uptake by *Puccinellia* may be as high as 57% that of ammonium

in the intertidal zone (see Results section). Results from short-term uptake experiments using doubly-labelled  $^{13}\text{C}^{15}\text{N}$ -glycine strongly suggest that much of the glycine is taken up intact by roots of *Puccinellia* and that the presence of ammonium and nitrate ions does not inhibit glycine uptake (Chapter 3). Glycine has a low molecular weight and rates of uptake of amino acids appear to be inversely proportional to their molecular weights (Kielland 1994), hence plants may not grow as well on other amino acids, or on mixtures of amino acids. Nevertheless, in these salt-marsh soils, the other amino acids present at high concentrations include alanine and proline which also have a low molecular weight and consequently may be readily taken up by *Puccinellia*. In addition, given the range of specific neutral, basic and acidic amino acid transporters expressed in roots (Fischer *et al.* 1998), growth on a mixture of amino acids may be beneficial to plants because competition between individual amino acids for transporter sites is minimized.

Results from the continuous flow experiment indicate that at typical soil concentrations of 100  $\mu\text{M}$  nitrogen, observed transpiration rates are insufficient to replenish nitrogen at the root surface via mass flow alone assuming steady state conditions (Table 2.1). Diffusion must contribute to nitrogen movement to the root surface, especially at low external concentrations of soluble nitrogen. Because depletion zones occur in the vicinity of roots, as a result of uptake and microbial demand for nitrogen in the rhizosphere (Nye and Tinker 1977, Jones 1999), bulk soil solution concentrations are generally inaccurate as estimates of ionic concentrations at the root surface (Nye 1969, Tinker 1969). Hence, calculations of the mass-flow contribution based on the bulk soil concentration that help maintain the concentration of nitrogen at the root surface tend to overestimate this contribution.

Under field conditions depletion of N at the root surface is likely to be exacerbated compared with that in water culture, because of enhanced root competition and restricted water flow in soils. Concentrations of  $\text{NH}_4^+$ -N in the soil solution fall coincident with the increase in biomass of this forage grass and the onset of intensive goose grazing (Fig 2.2; Cargill and Jefferies 1984b; Jefferies 1988a,b; Wilson and Jefferies 1996). *Puccinellia* has no well developed storage organs: it produces a new set of roots each year, and the small number of leaves that survive the winter are replaced shortly after spring melt, hence the internal N pool is limited and is mainly confined to the shoot (Bazely and Jefferies 1989a,b; Srivastava and Jefferies 1995). Regrowth of shoots following defoliation by geese creates a N demand at a time when exchangeable and soluble inorganic N in soils is low (Fig. 2.2, Wilson and Jefferies 1996).

Experimental studies indicate that not only are faecal droppings necessary for regrowth of vegetation following grazing, but also that multiple grazings (with attendant droppings) are more likely to meet N demands for continuous growth of the grazed grass crop (Hik and Jefferies 1990; Hik *et al.* 1991; see also Prins, Ydenberg and Drent 1980). The feedback results in increased net above-ground primary production compared with that of ungrazed or infrequently grazed swards. Soluble nitrogen sources injected into swards are incorporated into plant tissue within 48 hours, based on tracer studies with  $^{15}\text{N}$  (Kotanen 2002). The similarity between the amino acid profiles in faeces and soils (Fig. 2.5) indicates that the ubiquitous presence of fresh droppings throughout the season and the rapid loss of soluble nitrogen from faeces likely accounts for the similarity.

These results, together with those published elsewhere, indicate that soluble organic nitrogen appears to play a significant role in the nitrogen economy of this forage

grass at a time when grazing is intense and inorganic N supplies, as exchangeable and soluble ammonium ions, are low (Wilson and Jefferies 1996). Facilitation by the consumer ensures regrowth at a critical time in the phenology of grazed swards.

### **Chapter 3: Interactions in the uptake of amino acids, ammonium and nitrate ions in the Arctic salt-marsh grass, *Puccinellia phryganodes***

#### **3.1 Abstract**

The uptake of amino acids and inorganic nitrogen by roots of *Puccinellia phryganodes* was examined to assess the potential contribution of soluble organic nitrogen to nitrogen uptake. Short-term excised root uptake experiments were performed using tillers grown hydroponically under controlled conditions in the field. Percent reductions in ammonium uptake at moderate salinity (150 mM NaCl) compared with uptake at low salinity (50 mM NaCl) were double those of glycine, but glycine uptake was more adversely affected than ammonium uptake by low temperatures. Glycine uptake was higher at pH 5.7 than at pH 7.0 or 8.2. Glycine uptake was up-regulated moderately in plants grown on glycine, whereas ammonium uptake was up-regulated in response to ammonium starvation. Nitrate uptake was strongly down-regulated when tillers were grown on ammonium or glycine. In contrast to N-starved roots, which absorbed ammonium ions more rapidly than glycine, roots grown on glycine, ammonium and nitrate, and not N-starved prior to uptake, absorbed glycine as rapidly as ammonium and nitrate ions combined. Overall, the results indicate that amino acids are likely an important source of nitrogen for *P. phryganodes* in Arctic coastal marshes.

### 3.2 Introduction

The availability of nitrogen in forms accessible to plants is one of the primary factors that limits productivity in terrestrial ecosystems (White 1993). If plants can only utilize inorganic nitrogen uptake, as is often assumed in ecosystem-level nitrogen cycling models, then primary production is likely to be strongly affected by the rate of organic nitrogen mineralization (Giblin *et al.* 1991, Chapin 1995). However, recent evidence suggests that soil organic nitrogen, in the form of free amino acids, can be taken up rapidly by the roots of a wide variety of mycorrhizal and non-mycorrhizal plants, ranging from Arctic and alpine grasses, sedges and shrubs (Chapin, Moilanen and Kielland 1993, Kielland 1994, Raab, Lipson and Monson 1996, 1999), to boreal grasses, trees and shrubs (Näsholm *et al.* 1998), temperate crop plants (Shobert and Komor 1987, Jones and Darrah 1994, Näsholm, Huss-Danell and Högberg 2001) and tropical trees and shrubs (Turnbull *et al.* 1996). Direct uptake of amino acids by plant roots may uncouple primary production from nitrogen mineralization rates in ecosystems where free amino acids are readily available relative to soluble inorganic nitrogen (Chapin 1995). Hence, it calls into question the validity of nitrogen cycling models for these systems (Chapin 1995).

While free amino acid concentrations are often orders of magnitude lower than inorganic nitrogen concentrations in temperate soils, they account for a relatively large proportion of total available nitrogen for plant growth in Arctic systems, where low temperatures, low precipitation and a short growing season result in slow mineralization rates and a build-up of soluble organic nitrogen (Nadelhoffer *et al.* 1992, Kielland 1995, Atkin 1996). In Arctic coastal marshes, inorganic nitrogen availability is further limited

by high salinity, due to the inhibitory effects of chloride ions on nitrification (McClung and Frankenberger 1985, Wilson *et al.* 1999). High salinity also has a strong inhibitory effect on inorganic nitrogen uptake, particularly the uptake of nitrate (Cram 1973, Deane-Drummond and Glass 1982, Xu *et al.* 2000), although ammonium uptake is inhibited as well (Bradley and Morris 1990, Chambers, Mozdzer and Ambrose 1998). Rates of N uptake also diminish at low temperatures, although ammonium absorption is less sensitive to sub-optimal growth temperatures than nitrate absorption in some species (Clarkson, Hopper and Jones 1986, Clarkson, Jones and Purves 1992). Amino acids may be an important supplementary source of nitrogen in Arctic coastal marshes, provided that inhibitory effects of sodium chloride and low temperatures on amino acid uptake are not severe.

Soluble nitrogen concentrations in Arctic coastal marsh soils are highly variable, both in space and time (Chapter 2). This variability in nitrogen supply may have important implications for the relative rates of amino acid uptake in these systems, since the concentration of nitrogen substrates in soil solutions strongly influences their individual rates of uptake by roots. Root transport systems of inorganic nitrogen are regulated to respond rapidly to fluctuations in inorganic nitrogen sources (Glass *et al.* 1999). For example, high affinity ammonium transport is up-regulated in response to N-starvation and down-regulated in the presence of ammonium ions (Lee and Rudge 1986, Kronzucker, Siddiqi and Glass 1996). There is also a need for plants to integrate signals from several potential nitrogen pools in order to regulate total nitrogen uptake (Glass *et al.* 1999). This can lead to the favouring of one form of nitrogen over another, as in ammonium-dominated systems, where the presence of ammonium ions inhibits nitrate

transport in some species (Kronzucker, Siddiqi and Glass 1997, Kronzucker, Glass and Siddiqi 1999). Despite widespread evidence for the direct uptake of amino acids by roots, the role of external nitrogen sources in the regulation of amino acid transport systems is unknown, yet essential for estimating relative rates of amino acid uptake where different N sources are available.

The majority of ecological studies of amino acid uptake by plants are based on glycine uptake, as glycine is typically present at relatively high concentrations in the soil solution and can be taken up rapidly due, in part, to its low molecular weight relative to other amino acids (Kielland 1994, Lipson *et al.* 1999). However, in Arctic coastal marsh soils, alanine, proline and glutamic acid concentrations are higher than those of glycine and several other amino acids are present at concentrations equal to those of glycine (Chapter 2). Although a range of specific and general amino acid transporters are expressed in plant roots (Fischer *et al.* 1998), it is not known to what extent multiple transporters may alleviate competition between amino acids for transport sites, and how rapidly mixtures of amino acids are taken up relative to glycine alone.

In the present study, factors affecting the relative rates of amino acid and inorganic nitrogen uptake in the Arctic salt-marsh grass, *Puccinellia phryganodes*, were examined. Excised roots of tillers grown hydroponically under controlled conditions in the field were used to compare the uptake kinetics of <sup>15</sup>N-labelled amino acids, ammonium and nitrate ions and to quantify the effects of salinity, low temperatures, variation in pH and competition between nitrogen sources on uptake rates. Excised root experiments were also conducted to examine the regulation of amino acid and inorganic nitrogen uptake when tillers were grown on different nitrogen substrates. The combined

goal of these experiments was to assess the capability of the salt-marsh grass to utilize amino acids as a supplementary source of nitrogen under conditions similar to those in coastal soils.

### 3.3 Methods

#### 3.3.1 Study species and site description

*Puccinellia phryganodes* (Trin.) Scribn. and Merr. is a stoloniferous, halophytic graminoid that dominates intertidal salt-marshes along the Hudson Bay coast and is common in salt marshes in circumpolar regions (Hultén 1968). Net above-ground productivity of intact swards in coastal marshes of the Hudson Bay lowland is estimated to range between 100 and 150 g m<sup>-2</sup> year<sup>-1</sup> (Cargill and Jefferies 1984b, Hik and Jefferies 1990). Increases in primary productivity following addition of inorganic nitrogen to swards indicate that the availability of this element limits plant growth (Cargill and Jefferies 1984a). Soils in the intertidal zone have a greyish mineral horizon of marine sediment in which the upper 2.5 cm contains some organic material. Over the growing season from late May to late July, mean amino acid concentrations in soil solutions in the intertidal zone range from 32-45 µM, and ammonium and nitrate concentrations range from 55-160 and 10-31 µM respectively; however, soluble N concentrations obtained from individual soil samples can be as much as an order of magnitude higher (Chapter 2). Amino acids present at high concentrations are alanine, proline, glutamic acid, leucine, tyrosine, gamma amino-butyric acid and glycine. Soil pH averages 7.12 +/- 0.04 (standard error, n=24), and the salinity of extracted soil solutions can rise to as high as 1.5 M in late summer in intertidal sites devoid or nearly devoid of vegetation, although

NaCl concentrations typically range from 50-250 mM under high biomass swards of vegetation (Wilson and Jefferies 1996, Srivastava and Jefferies 1995)

### 3.3.2 Excised root experiments

Tillers of *Puccinellia phryganodes* were collected from a salt-marsh sward at La Pérouse Bay, Wapusk National Park, 25 km east of Churchill, Manitoba (58.43 °N, 94.28 °W). All tillers were collected from the same 1 m X 1 m patch in order to minimize genetic variability. Each shoot was approximately 2.5 cm high and root length was 3-5 cm. Each growing season, new roots replace those produced during the previous growing season. Tillers were stripped of old root material and placed in an aerated solution containing one-tenth strength Hoagland's macronutrients (ammonium nitrate as the N source) (Hoagland and Arnon 1950), 0.2 mM Fe-EDTA and 50 mM NaCl at a density of 12 tillers per 4 litre container. Nutrients were dissolved in calcium/magnesium-rich river water due to the limited availability of deionized water in the field. The river water was fast-flowing and well-aerated and contained no detectable ammonium or nitrate (water was sampled weekly; the lower detection limit of N was 0.7 µM). Containers (black high-density polyethylene) were placed in a herbivore exclosure in a supratidal marsh at La Pérouse Bay and sunk into the soil to maintain water temperature within 1° C of soil temperature at rooting depth. Tillers were grown hydroponically for 5-6 weeks and solutions were replaced every four days. Based on the rate of N accumulation in plant tissue, the draw-down of N from growth solutions was < 5% over four days. The pH of growth solutions remained over this period at approximately 7.5. Forty-eight hours prior

to the start of uptake experiments, tillers were starved of nitrogen by immersing roots in 0.5 mM  $\text{CaCl}_2$  and 50 mM  $\text{NaCl}$  dissolved in river water.

The availability of root material for experiments was limited given the slow growth rate of our study species (the dry weight of roots of each tiller obtained from the field was less than 2 mg). Root excision allowed us to pool roots of a large number of tillers and to apportion precise quantities of root to each replicate. Roots were excised, blotted and weighed into samples of 180 mg. Based on a modified method of Epstein, Schmid and Rains (1963), samples were placed in cheesecloth "teabags", kept in an aerated holding solution of 0.5mM  $\text{CaCl}_2$  and 50mM  $\text{NaCl}$  and allowed to equilibrate at the temperature of the experimental solution for 20 minutes (deionized water was used throughout all steps of the uptake experiments). After equilibration, roots were placed for 20 minutes in 200 ml of a well-aerated solution identical to the holding solution but containing a  $^{15}\text{N}$ -labelled substrate (Sigma-Aldrich, specific activity of 99%). Pilot trials using ammonium and glycine indicated that the relationship between total uptake and time was linear for at least the first 50 minutes of uptake after excision. The pH of incubation solutions was 7.0. Following absorption, roots were rinsed for five minutes in a solution of 5 mM  $\text{KCl}$  to remove label left in the Donnan free space, then dried at 60 °C. Dried root material was ground to a fine powder and analysed for its N content and  $^{15}\text{N}/^{14}\text{N}$  ratio relative to unenriched control samples using an Isochrom continuous flow stable isotope mass spectrometer (Micromass) coupled to a Carla Erba elemental analyzer (CHNS-O EA1108). Isotopic analyses were performed by the University of Waterloo Environmental Isotope Laboratory. Data of the  $^{13}\text{C}/^{12}\text{C}$  ratio and C content of tissues (see below) were also obtained.

In order to characterize uptake kinetics, uptake of  $^{15}\text{N}$ -labelled glycine, aspartic acid, glutamic acid, leucine,  $^{15}\text{NH}_4\text{Cl}$  and  $\text{K}^{15}\text{NO}_3$  was measured for two replicates at concentrations of 0, 10, 12, 15, 20, 30, 55 and 500  $\mu\text{M}$  at 18  $^\circ\text{C}$ . This range of concentrations was selected to give a uniform coverage of points on a reciprocal axis. Uptake of a mixture of equal concentrations of  $^{15}\text{N}$ -labelled common salt-marsh amino acids (glycine, aspartic acid, glutamic acid, leucine, proline and alanine) was also measured, and uptake of  $^{13}\text{C}^{15}\text{N}$ -labelled glycine was examined to determine whether the amino acid was taken up intact into roots. For both the amino acid mixture and  $^{13}\text{C}^{15}\text{N}$ -labelled glycine, total amino acid concentration ranged from 0-500  $\mu\text{M}$  (as above).

$^{15}\text{N}$ -glycine and  $^{15}\text{NH}_4\text{Cl}$  uptake rates at a higher salinity (150 mM NaCl) were compared with those at the same range of external  $^{15}\text{N}$  concentrations used for uptake trials at 50 mM NaCl (n=2).  $^{15}\text{N}$ -glycine and  $^{15}\text{NH}_4\text{Cl}$  uptake rates at external  $^{15}\text{N}$  concentrations of 10 and 100  $\mu\text{M}$  (n=3) were also measured at 2, 5 and 18  $^\circ\text{C}$  (n=3) and at a pH of 5.7, 7.0 and 8.2, where the external  $^{15}\text{N}$  concentration was 100  $\mu\text{M}$  (n=3).  $\text{NaH}_2\text{PO}_4\cdot\text{H}_2\text{O}$  and HCl were titrated to obtain pH 5.7,  $\text{Na}_2\text{HPO}_4\cdot 2\text{H}_2\text{O}$  and NaOH were titrated to obtain pH 8.2 and both  $\text{NaH}_2\text{PO}_4\cdot\text{H}_2\text{O}$  and  $\text{Na}_2\text{HPO}_4\cdot 2\text{H}_2\text{O}$  were titrated to obtain pH 7.0. All pH treatments received equal concentrations of sodium phosphate and roots were pH acclimated for two weeks prior to excision (additions of Na and Cl from NaOH and HCl were less than 2% of their concentrations in the background solutions). Substrate competition trials were conducted by measuring uptake of  $^{15}\text{N}$ -labelled substrates in the presence of 100  $\mu\text{M}$  of unlabelled  $\text{NH}_4\text{Cl}$ ,  $\text{NaNO}_3$ , glycine, aspartic acid, glutamic acid or a mixture of amino acids (glycine, glutamic acid, aspartic acid, leucine, alanine, proline and lysine mixed equally to give a total final concentration of 100  $\mu\text{M}$ ).

A total concentration of 100  $\mu\text{M}$  was selected for competing substrates as it approximates to concentrations typically present in soil solutions under field conditions. The uptake of  $^{15}\text{N}$ -labelled substrates was measured for two replicates at concentrations ranging from 0-500  $\mu\text{M}$  (see above).

Methods used for substrate regulation trials departed slightly from methods used for other uptake trials. Tillers were grown on 50 mM NaCl and one-tenth strength nitrogen-free Hoagland's solution to which was added one of the four following nitrogen substrates: glycine,  $\text{NH}_4\text{Cl}$ ,  $\text{NaNO}_3$  or an equal mixture of all three substrates. Tillers were assigned at random to the different treatments. The total N concentration of each growth solution was 1.6 mM, equal to that of one-tenth strength Hoagland's solution and solutions were changed every two days. After six weeks of growth, tillers grown on a given nitrogen source were randomly re-assigned to growth on either glycine, or  $\text{NH}_4\text{Cl}$  or  $\text{NaNO}_3$  (all 1.6 mM N). Uptake of the newly introduced nitrogen source was measured at a concentration of 100  $\mu\text{M}$   $^{15}\text{N}$  for roots excised after 0, 1, 3 and 7 days ( $n=3$ ). On day 0, tillers grown on an equal mixture of glycine,  $\text{NH}_4\text{Cl}$ , and  $\text{NaNO}_3$  were used as a control. On days 1, 3 and 7, excised roots from tillers grown on the same N substrate as the given  $^{15}\text{N}$  substrate, but in the absence of other N substrates, were used as controls. Roots were not starved prior to excision for substrate regulation trials.

### 3.3.3 Data analyses

For excised root experiments, maximum uptake rate ( $V_{\text{max}}$ ) and the half saturation constant ( $K_m$ ) were estimated by fitting ordinary least squares regression lines to double reciprocal plots of uptake rate versus concentration. Regression lines were back-

transformed to a linear scale for curve fitting. Although double reciprocal plots may augment errors (Eisenthal and Cornish-Bowden 1974), they produced similar  $k_m$  and  $V_{max}$  values as direct linear plot methods and ensured a tight fit at low substrate concentrations (which are within the range of typical concentrations in the soil solution). For salinity trials (Table 3.1) and substrate competition between glycine,  $NH_4Cl$  and  $NaNO_3$  (Table 3.4), predicted uptake rates at a concentration of  $100\mu M$   $^{15}N$ , a typical N concentration present in salt-marsh soils, were interpolated from regression lines for the purpose of comparison. In the amino acid competition trials (Table 3.5), the difference between uptake of an amino acid at an external concentration of  $100\mu M$   $^{15}N$  in the absence and presence of  $100\mu M$  N mixed cocktail of amino acids was expressed as a percentage of the difference between uptake of the amino acid alone at  $100\mu M$   $^{15}N$  and one half of its uptake at  $200\mu M$   $^{15}N$ . This value, termed 'percent competition' in the context of this study, expresses uptake of an amino acid in terms of the outcome of competition from other amino acids at comparable concentrations of total soluble N.

### 3.4 Results

#### 3.4.1 Uptake of $^{15}N$ by excised roots

Uptake kinetics of ammonium, nitrate and amino acids by roots N-starved for 48 h approached saturation at low external concentrations (10-55  $\mu M$ ) (Fig. 3.1a). With the exception of ammonium uptake, where the standard error was relatively large, curves obtained from double reciprocal plots underestimated uptake at 500  $\mu M$ . The most rapid rates of amino acid uptake were exhibited by glycine, which was taken up from 20 to 50% faster than leucine, glutamic acid and aspartic acid at concentrations between 10 and 55  $\mu M$ , the range of concentrations typically encountered in salt-marsh soils (Fig. 3.1b).

**Fig. 3.1.** Plots of uptake rate versus substrate concentration for excised roots of *P. phryganodes* provided with  $^{15}\text{N}$  and  $^{13}\text{C}$ -labelled substrates in short-term uptake experiments (all tillers grown on  $\text{NH}_4\text{NO}_3$ ). Curves were obtained by back-transforming OLS linear fits to double reciprocal plots of uptake rate versus concentration. For each substrate, the following estimates of  $K_m$  ( $\mu\text{M}$ ) and  $V_{\max}$  ( $\mu\text{mol g}^{-1} \text{h}^{-1}$ ) were obtained respectively:  $^{15}\text{N}$ -glycine (37.1, 13.5),  $^{15}\text{N}$ -ammonium (57.6, 66.5),  $^{15}\text{N}$ -nitrate (1.4, 6.2),  $^{13}\text{C}$ -glycine (56.6, 7.5),  $^{15}\text{N}$ -glutamic acid (66.2, 13.2),  $^{15}\text{N}$ -aspartic acid (42.2, 8.7),  $^{15}\text{N}$ -leucine (21.7, 8.9), mixture of  $^{15}\text{N}$ -alanine, aspartic acid, glutamic acid, glycine, leucine and proline (13.8, 9.9). Error bars denote standard error

a)

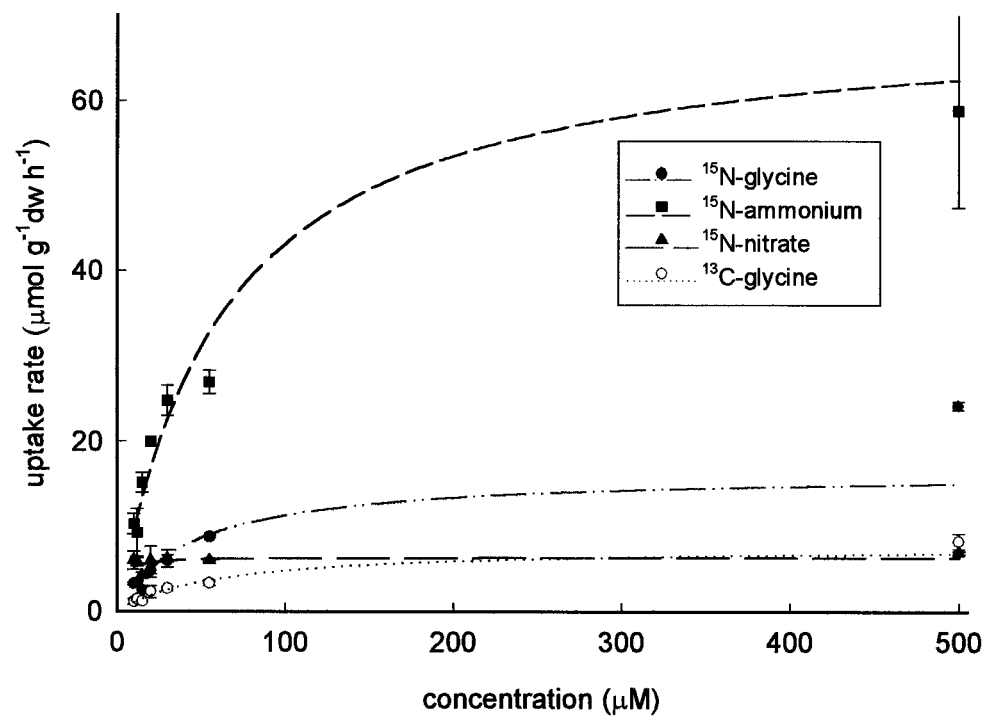

b)

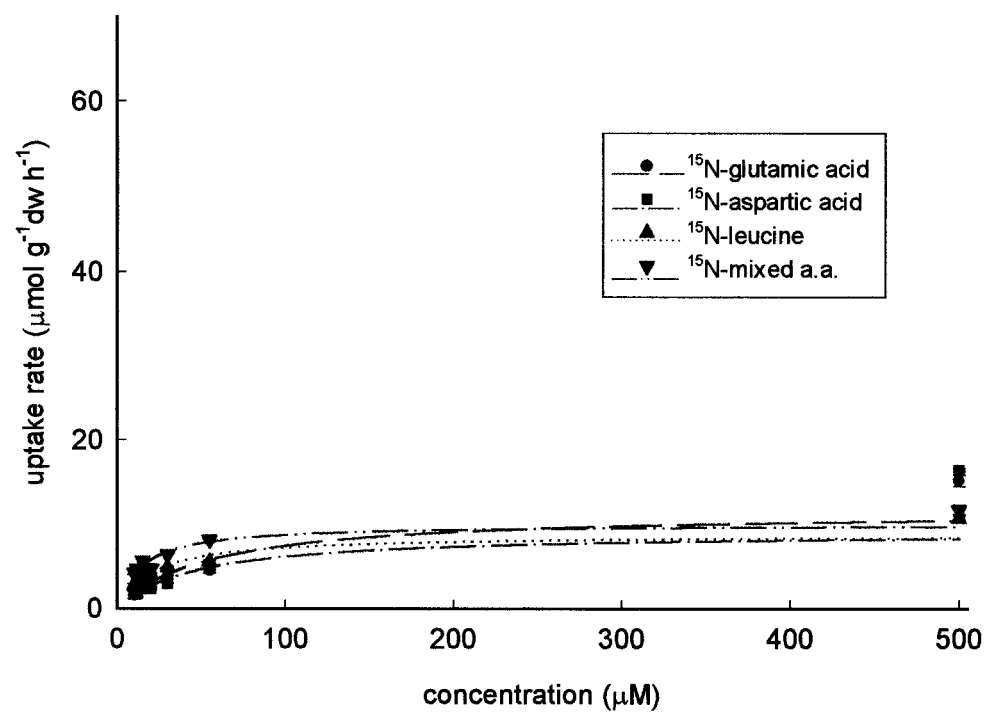

A mixture of  $^{15}\text{N}$ -labelled alanine, aspartic acid, leucine, glutamic acid, glycine and proline was taken up at a rate comparable to that of glycine alone over the same range of concentrations (Fig. 3.1b). The uptake of  $^{13}\text{C}$  from  $^{13}\text{C}^{15}\text{N}$ -labelled glycine indicated that this amino acid was taken up intact; however, rates of  $^{13}\text{C}$  uptake were only one third to one half those of  $^{15}\text{N}$  uptake (Fig. 3.1a). Ammonium ions were taken up three to four times as fast as glycine over the range of concentrations tested, whereas uptake rates of nitrate were low, and the process saturated at very low concentrations relative to the uptake of amino acids (Fig. 3.1a). Based on rates of  $^{15}\text{N}$  uptake, draw-down of  $^{15}\text{N}$  in incubation solutions was  $< 5\%$  (with the exception of low concentration ammonium solutions, which were drawn down by as much as  $15\%$  by N-starved roots).

#### **3.4.2 Effects of salinity, temperature, pH and competition between N sources on uptake rates**

At an external N concentration of  $100\ \mu\text{M}$ , the rate of glycine uptake was  $20\%$  lower at moderate salinity ( $150\ \text{mM}$ ) than at low salinity ( $50\ \text{mM NaCl}$ ), whereas the rate of ammonium uptake was  $35\%$  lower ( $\pm 7\%$ ,  $95\%$  C.I.) at moderate salinity than at low salinity (Table 3.1). In contrast, the difference between uptake at  $2$  or  $5\ ^\circ\text{C}$  relative to uptake at  $18\ ^\circ\text{C}$  was greater for glycine than for ammonium (Table 3.2). Ammonium uptake rates increased with increasing alkalinity of the external solution, whereas glycine uptake rates increased with increasing acidity (Table 3.3). In competition trials between glycine, ammonium and nitrate, the presence of  $100\ \mu\text{M}$  nitrate had no detectable effect on rates of glycine uptake, and glycine uptake at an external  $^{15}\text{N}$  concentration of  $100\ \mu\text{M}$  was reduced by  $12\%$  ( $\pm 10\%$ ,  $95\%$  C.I.) in the presence of  $100\ \mu\text{M}$  ammonium

**Table 3.1.** Uptake kinetics of  $^{15}\text{N}$ -glycine and  $^{15}\text{N}$ -ammonium by excised roots of *Puccinellia phryganodes* at low and moderate salinity (50 mM and 150 mM NaCl, respectively). Affinity ( $K_m$ ), maximum uptake rate ( $V_{\max}$ ) and the correlation coefficient ( $r^2$ ) were estimated by plotting uptake rate against labelled substrate concentration in a double reciprocal (Lineweaver-Burk) plot.

Uptake rate at 100  $\mu\text{M}$   $^{15}\text{N}$  was interpolated from regression for the purposes of comparison.

substrate	[NaCl]	$K_m$ ( $\mu\text{mol L}^{-1}$ )	$V_{\max}$ ( $\mu\text{mol g}^{-1} \text{dw h}^{-1}$ )	$r^2$	uptake rate at 100 $\mu\text{M}$ $^{15}\text{N}$ ( $\mu\text{mol g}^{-1} \text{dw h}^{-1}$ )
$^{15}\text{N}$ -glycine	50	63.0	22.3	0.98	13.7
$^{15}\text{N}$ -glycine	150	56.5	17.1	0.98	10.9
$^{15}\text{N}$ -ammonium	50	36.1	75.2	0.99	55.3
$^{15}\text{N}$ -ammonium	150	29.1	46.3	1.00	35.9

**Table 3.2.** Uptake rates of 10  $\mu\text{M}$  and 100  $\mu\text{M}$   $^{15}\text{N}$ -glycine and  $^{15}\text{N}$ -ammonium ions by excised roots of *Puccinellia phryganodes* at 2, 5 and 18  $^{\circ}\text{C}$  ( $\mu\text{mol g}^{-1} \text{dw h}^{-1}$ ). Means and standard errors were calculated for each treatment ( $n=3$ ).

temperature ( $^{\circ}\text{C}$ )	$^{15}\text{N}$ -glycine		$^{15}\text{N}$ -ammonium	
	10 $\mu\text{M}$ mean (s.e.)	100 $\mu\text{M}$ mean (s.e.)	10 $\mu\text{M}$ mean (s.e.)	100 $\mu\text{M}$ mean (s.e.)
2	1.00 (0.09)	2.83 (0.03)	13.78 (1.55)	40.08 (4.52)
5	1.63 (0.08)	5.50 (0.24)	21.04 (0.79)	59.56 (3.14)
18	3.54 (0.13)	8.93 (0.66)	27.26 (2.18)	69.75 (8.30)

**Table 3.3.** Uptake rates of 100  $\mu\text{M}$   $^{15}\text{N}$ -glycine,  $^{15}\text{N}$ -ammonium and  $^{15}\text{N}$ -nitrate by excised roots of *Puccinellia phryganodes* at a pH 5.7, 7.0 and 8.2 ( $\mu\text{mol g}^{-1} \text{dw h}^{-1}$ ). Means and standard errors were estimated for each treatment (n=3).

pH	$^{15}\text{N}$ -glycine	$^{15}\text{N}$ -ammonium	$^{15}\text{N}$ -nitrate
	mean (s.e.)	mean (s.e.)	mean (s.e.)
5.7	18.3 (0.3)	61.8 (6.5)	9.9 (2.5)
7	13.2 (0.8)	63.8 (11.2)	10.2 (1.7)
8.2	10.4 (0.7)	76.1 (9.4)	8.6 (1.1)

**Table 3.4.** Uptake kinetics of  $^{15}\text{N}$ -glycine and  $^{15}\text{N}$ -ammonium ions by excised roots of *Puccinellia phryganodes* in the presence and absence of unlabelled competing nitrogen sources. All tillers were grown on  $\text{NH}_4\text{NO}_3$ .  $K_m$ ,  $V_{\text{max}}$ ,  $r^2$  and uptake rate at 100  $\mu\text{M}$  were estimated as in Table 1.

substrate	competing substrate (100 $\mu\text{M}$ )	$K_m$ ( $\mu\text{mol L}^{-1}$ )	$V_{\text{max}}$ ( $\mu\text{mol g}^{-1} \text{dw h}^{-1}$ )	$r^2$	uptake rate at 100 $\mu\text{M}$ $^{15}\text{N}$ ( $\mu\text{mol g}^{-1} \text{dw h}^{-1}$ )
$^{15}\text{N}$ -glycine	-	46.0	15.2	0.97	10.4
$^{15}\text{N}$ -glycine	ammonium	60.9	14.8	0.91	9.2
$^{15}\text{N}$ -glycine	nitrate	38.5	14.3	0.96	10.3
$^{15}\text{N}$ -ammonium	-	63.1	70.4	0.91	43.2
$^{15}\text{N}$ -ammonium	glycine	26.6	44.8	0.75	35.4
$^{15}\text{N}$ -ammonium	nitrate	20.9	50.8	0.75	42.0

**Table 3.5.** Uptake kinetics of  $^{15}\text{N}$ -glycine,  $^{15}\text{N}$ -glutamic acid and  $^{15}\text{N}$ -aspartic acid by excised roots of *Puccinellia phryganodes* in the presence and absence of a mixture of 100  $\mu\text{M}$  unlabelled amino acids (a.a.) (equal concentrations of alanine, aspartic acid, glutamic acid, glycine, leucine, lysine and proline).

$K_m$ ,  $V_{\max}$  and  $r^2$  were estimated as in Table 1. Percent competition at 100  $\mu\text{M}$   $^{15}\text{N}$  was calculated by expressing the difference between uptake of the amino acid in the absence and presence of 100  $\mu\text{M}$  mixed amino acids as a percentage of the difference between uptake at 100  $\mu\text{M}$  and one half of uptake at 200  $\mu\text{M}$  in the absence of competing amino acids.

substrate	competing ion (100 $\mu\text{M}$ )	$K_m$ ( $\mu\text{mol L}^{-1}$ )	$V_{\max}$ ( $\mu\text{mol g}^{-1} \text{dw h}^{-1}$ )	$r^2$	percent competition at 100 $\mu\text{M}$ $^{15}\text{N}$
$^{15}\text{N}$ -glycine	-	23.7	15.3	0.91	n.a.
$^{15}\text{N}$ -glycine	a.a. mixture	50.2	12.9	0.93	69.0
$^{15}\text{N}$ -glutamic acid	-	14.2	8.1	0.68	n.a.
$^{15}\text{N}$ -glutamic acid	a.a. mixture	33.8	7.1	0.90	54.0
$^{15}\text{N}$ -aspartic acid	-	22.1	7.5	0.67	n.a.
$^{15}\text{N}$ -aspartic acid	a.a. mixture	29.1	4.2	0.70	105.0

(Table 3.4). Likewise, the interference of nitrate with rates of ammonium uptake was minimal, but decreases in ammonium uptake of 18% (+/- 15%, 95% C.I.) occurred in the presence of glycine (Table 3.4). Estimates of percent competition between a mixture of unlabelled, common salt-marsh amino acids (total concentration of 100  $\mu\text{M}$ ) and individual amino acids,  $^{15}\text{N}$ -glycine,  $^{15}\text{N}$ -glutamic acid and  $^{15}\text{N}$ -aspartic acid, each at an external  $^{15}\text{N}$  concentration of 100  $\mu\text{M}$ , were 69, 54 and 105% respectively (Table 3.5).

### 3.4.3 Regulation of nitrogen uptake by substrates

Uptake of glycine by tillers grown on an equal mixture of glycine,  $\text{NH}_4\text{Cl}$  and  $\text{NaNO}_3$  exceeded that of tillers grown solely on ammonium or nitrate at day 0 (Fig. 3.2a). For tillers grown on ammonium and nitrate, rates of glycine uptake increased from day 0 to day 3, but subsequently decreased to intermediate values from day 3 to day 7.

Differences in glycine uptake between control (glycine-grown) tillers at days, 1, 3 and 7 were not significant (one-way ANOVA,  $df=2, 6, F=2.26, P=0.19$ ). Tillers grown in the absence of ammonium, particularly those grown solely on nitrate, took up ammonium rapidly on day 0 relative to plants grown on a mixture of all three substrates (Fig. 3.2b). Rates of ammonium uptake by nitrate- and glycine-grown tillers rapidly decreased by day 1. Differences in ammonium uptake between control (ammonium-grown) tillers at days 1, 3 and 7 were not significant (one-way ANOVA,  $df=2, 6, F=2.91, P=0.13$ ). For nitrate, uptake rates at day 0 were very low for tillers grown solely on ammonium or glycine or on a mixture of all three substrates (Fig. 3.2c). On day 1, uptake of nitrate by glycine- and ammonium-grown tillers remained low relative to uptake of nitrate by tillers grown solely on nitrate. Nitrate uptake increased for glycine- and ammonium-grown tillers between day 3 and day 7. Differences in nitrate uptake between control (nitrate-grown) tillers at days 1, 3 and 7 were not significant (one-way ANOVA,  $df=2, 6, F=0.90, P=0.45$ ).

**Fig. 3.2.** Plots of a)  $^{15}\text{N}$ -glycine uptake, b)  $^{15}\text{N}$ -ammonium uptake and c)  $^{15}\text{N}$ -nitrate uptake by excised roots of *Puccinellia phryganodes* at an external  $^{15}\text{N}$  concentration of  $100\ \mu\text{M}$  (note that Y-axis scales differ among plots). Treatments (see symbol key in figure) refer to the nitrogen source tillers were grown on until day 0. The mixed treatment refers to tillers grown on equal concentrations of glycine, ammonium and nitrate at the same total nitrogen concentration as other nitrogen treatments. Thereafter, tillers were grown on the same nitrogen source as used in  $^{15}\text{N}$  uptake trials. In each panel, control tillers (i.e. initial N source was the same as the  $^{15}\text{N}$  source) are denoted by bold lines interconnecting points. Points indicate mean and standard error ( $n=3$ ).

a)

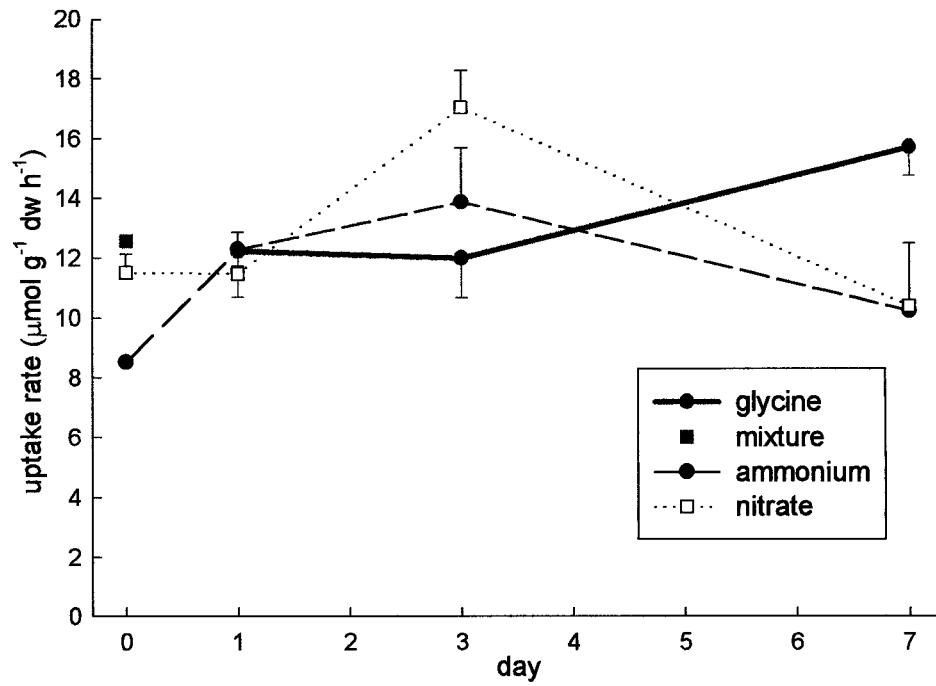

b)

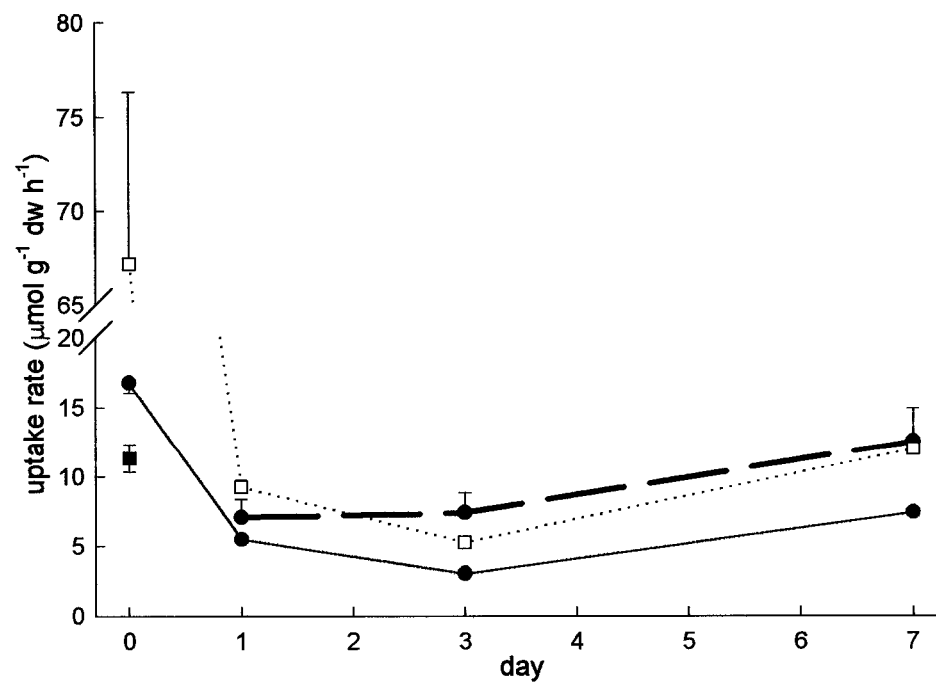

c)

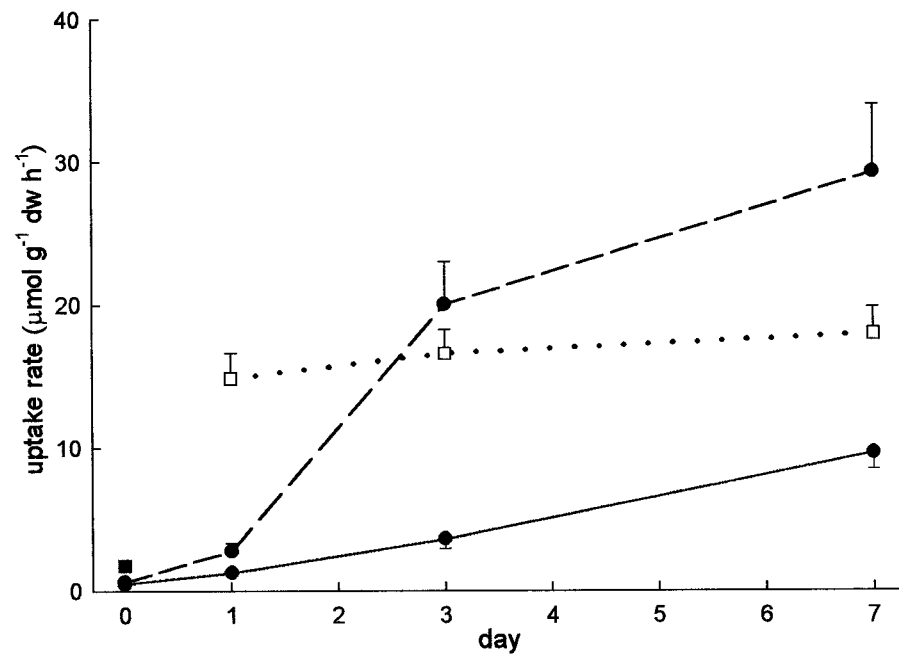

### 3.5 Discussion

Rates of amino acid uptake by excised roots of *P. phryganodes* were within the range of those reported in the literature for Arctic and alpine plants (Chapin *et al.* 1993, Kielland 1994, Raab *et al.* 1996, 1999). Uptake kinetics of amino acids were characterized by a high-affinity component that saturated at low external amino acid concentrations (Fig 3.1. a, b). Based on the tendency for fitted curves to underestimate uptake of the different nitrogen sources at 500  $\mu\text{M}$ , it is probable that a non-saturable, low-affinity component contributes to uptake at higher concentrations, as first described by Epstein, Rains and Elzam (1963) for  $\text{K}^+$  transport. This combination of low- and high-affinity transport systems is analogous to root transport systems typically present for ammonium and nitrate (Glass *et al.* 1999) and is supported by the cloning of both low- and high-affinity root amino acid transporters in *Arabidopsis* (see Fischer *et al.* 1998). Although root excision may reduce rates of N uptake relative to intact plants, such reductions are not commonly observed within 1-2 h following excision (Bloom and Caldwell 1988, Huang *et al.* 1992). For *Puccinellia*, uptake remained linear up to at least 50 minutes following excision, which indicates that excision-induced reductions in uptake did not occur over the time course of the incubations. Roots may also exhibit a pulse in N efflux following excision; however, this effect is transient and net uptake recovers within several minutes (Aslam *et al.* 1996).

Across the range of concentrations tested, the rate of glycine uptake by N-starved roots was approximately one-third that of ammonium ions and nitrate uptake was minimal (Fig. 3.1a). This result contrasts that obtained for non-starved roots grown on an equal mixtures of all three N substrates, where glycine uptake equalled the combined

uptake of ammonium and nitrate (Fig. 3.2 - see below). The uptake of  $^{13}\text{C}$  when roots were provided with  $^{13}\text{C}^{15}\text{N}$ -glycine indicated that at least a portion of each amino acid was likely taken up intact and not mineralized at the root surface.  $^{13}\text{C}$  uptake was only up to 50% as high as  $^{15}\text{N}$  uptake, which indicates that some amino acids may have been deaminated prior to uptake of the  $^{15}\text{N}$  moiety. Although the uptake media were sterile, traces of bacterial contamination may have been present on the surface of roots (*P. phryganodes* is a sterile tripliod and must be cultured from tillers as opposed to seed). In many algae and fungi, extracellular deamination of amino acids can occur at the cell surface, followed by uptake of ammonium ions (Paul & Cooksey 1979, 1981, DeBusk *et al.* 1981, Munoz-Blanco, Hidalgo-Martínez & Cárdenas 1990). Although extracellular deaminases have not been localized on the surface of root cell membranes, hypothetically, their presence could explain the low  $^{13}\text{C}$  incorporation of  $^{13}\text{C}^{15}\text{N}$ -amino acids from hydroponic media.  $^{13}\text{C}$  may be underestimated in  $^{13}\text{C}^{15}\text{N}$ -amino acid uptake experiments because of the high background quantity of  $^{13}\text{C}$  in root tissue relative to  $^{15}\text{N}$  and the large error associated with this dilution of the  $^{13}\text{C}$  signal (Näsholm and Persson 2001, Nordin, Högberg and Näsholm 2001). Losses of  $^{13}\text{C}$  may also occur as a result of root respiration (Schimel and Chapin 1996), but substantial respiratory losses of  $^{13}\text{C}$  would have been unlikely in the present study given the short incubation time.

Despite the capability of roots to take up a wide range of amino acids, it has been suggested that glycine is the only amino acid taken up rapidly relative to inorganic nitrogen due to its neutral charge and low molecular weight (Kielland 1994, Lipson *et al.* 1999). If correct, this would limit the contribution of amino acids to plant nitrogen nutrition in salt-marsh systems, where total amino acid concentrations are comparable to

ammonium concentrations but comprised of only 3-4% glycine N, on average (Chapter 2). In the present study, the uptake rate of a mixture of  $^{15}\text{N}$ -amino acids was comparable to that of glycine alone between 10-55  $\mu\text{M}$  and uptake rates of leucine, glutamic acid and aspartic acid (each tested separately) were at least half of those of glycine over the same range of concentrations (Fig. 3.1a, b). Therefore, other amino acids besides glycine likely contribute substantially to total amino acid uptake, particularly when their combined concentration greatly exceeds that of glycine. In substrate competition trials, the uptake of individual  $^{15}\text{N}$ -amino acids did decrease somewhat in the presence of a mixture of unlabelled amino acids at typical field concentrations, suggesting that the uptake rates of individual amino acids tested in isolation are not simply additive (Table 3.5). However, when the total amino acid concentration was held constant, the effect of competition from other amino acids on the uptake of an amino acid was less severe, on average, than the relative decline in the rate of uptake associated with its saturation kinetics at higher concentrations (200  $\mu\text{M}$ ). These results provide indirect evidence for the expression of multiple root amino acid transporters with some degree of specificity, as described in Fischer *et al.* (1998).

Uptake trials at moderate salinity (150 mM NaCl) revealed that percent reductions in ammonium uptake rates relative to uptake at low salinity (50 mM NaCl) were double those of glycine (Table 3.1). In contrast, reductions in uptake rates at low temperatures were higher for glycine than for ammonium ions (Table 3.2). These results suggest that the relative contribution of amino acid uptake to total nitrogen uptake may increase as the growing season progresses due to the presence of higher salinities and warmer temperatures. These rapid rates of uptake would be enhanced by the relatively high

concentrations of amino acids present in the soil solution at this time (Chapter 2).

Biomass production and nitrogen acquisition are also highest from mid- to late growing season due to warm temperatures, further increasing the demand for amino acids as a nitrogen source in *P. phryganodes*.

The rapid uptake of glycine by roots of *P. phryganodes* at pH 5.7 is consistent with the pH optima for the uptake of amino acids by barley roots, which range, for the most part, from pH 4 to pH 6 (Soldal and Nissen 1978). In contrast to glycine, ammonium uptake was relatively low at pH 5.7 relative to uptake at neutral or alkaline pH. This trend has also been shown for *Lolium perenne*, where the uptake rate of glycine relative to that of ammonium was greater at pH 6 than at pH 9 (Thornton 2001). The pH of salt marsh soil solution is neutral and temporal and spatial variability in pH are low (Wilson and Jefferies 1996). However, plants that take up nitrogen primarily as ammonium (as opposed to nitrate) tend to lower the pH of the rhizosphere, such that it is more acidic than the pH of the bulk soil solution (Nye 1981). Therefore, it is conceivable that root acidification may favour glycine uptake over ammonium uptake in *P. phryganodes*.

The presence of 100  $\mu$ M ammonium in excised root solutions over a 20 minute time course decreased glycine uptake by only 12%, and ammonium uptake was reduced by a comparably low amount in the presence of glycine (Table 3.4). Therefore, it does not appear that competition between inorganic and organic nitrogen sources would substantially alter their relative rates of uptake. However, results from the substrate regulation trials revealed that uptake of nitrogen by roots of *P. phryganodes* is highly sensitive to the presence of amino acids, ammonium and nitrate in the external growth

solution over the time scale of one to three days. Uptake of glycine by roots grown on a mixture of glycine, ammonium and nitrate exceeded uptake of glycine by roots grown solely on ammonium or nitrate previously (Fig. 3.2a), which provides evidence that glycine uptake is up-regulated (moderately) when plants are grown on glycine. This evidence was further supported by the increase in glycine uptake by plants initially grown on ammonium or nitrate after three days of exposure to glycine. Rates of glycine uptake by ammonium and nitrate grown plants at day zero were comparable to those rates of glycine uptake exhibited by ammonium or nitrate grown tillers starved 48 hours prior to root excision (Fig. 3.1a). Hence, it does not appear that glycine uptake is up-regulated by nitrogen starvation.

In contrast to glycine uptake, ammonium uptake was highly up-regulated in the absence of ammonium, particularly for roots grown solely on nitrate, and subsequently down-regulated after one day of exposure to ammonium (Fig. 3.2b). Rapid up-regulation of ammonium in response to nitrogen starvation and down-regulation in response to the presence of ammonium or amino acids in the external solution has been demonstrated in many species (Lee and Rudge 1986, Morgan and Jackson 1988, Kronzucker *et al.* 1996, Glass *et al.* 1999). This property of ammonium regulation has important implications for the estimation of relative rates of amino acid and ammonium uptake under field conditions. Uptake data derived from ammonium nitrate-grown roots starved for 48 hours prior to excision indicate that ammonium uptake is from three to four times greater than glycine uptake for any given concentration (Fig. 3.1a). Nevertheless, these data are an overestimation of ammonium uptake, which is rapidly up-regulated in response to nitrogen starvation and (they may also underestimate glycine uptake, which appears to be

down-regulated in the absence of glycine). In contrast, when tillers were supplied with all three nitrogen sources simultaneously and not starved prior to excision, glycine uptake slightly exceeded ammonium uptake (Fig. 3.2). However, these tillers were grown at nitrogen concentrations almost an order of magnitude higher than those typically encountered in salt-marsh soils, which could have resulted in the down-regulation of ammonium uptake. Although the relative uptake rates of glycine and ammonium presumably lie between these two extremes, the estimation of nitrogen concentrations experienced by roots in the field is not a trivial exercise. Estimations of nitrogen concentrations in the soil solution often are overestimates of nitrogen concentrations at the root surface, due to the formation of diffusion gradients close to the root surface (Nye 1969), and the effect of rhizosphere microbial activity (Schobert, Kockenberger and Komor 1988, Lipson and Monson 1998, Jones 1999). Furthermore, roots likely experience pulses of high soluble N concentrations as a result of rapid microbial and root cell lysis following freeze-thaw cycles (Hobbie & Chapin 1996) or as a result of goose faecal deposition (Ruess, Hik & Jefferies 1989). Although mean soil solution concentrations of N in free amino acids, ammonium and nitrate ions combined range from 100-200  $\mu\text{M}$  over the growing season ( $n=18$ ), mean concentrations early in the season and concentrations of individual soil samples throughout the growing season can be an order of magnitude higher (Chapter 2).

In the absence of ammonium or glycine, nitrate uptake was up-regulated by the presence of nitrate in the external solution (Fig. 3.2), consistent with the regulation pattern of high affinity nitrate transport exhibited by most species (Lee 1982, Siddiqi *et al.* 1990, Kronzucker, Siddiqi and Glass 1995). However, nitrate uptake was minimal in the

presence of glycine or ammonium ions. The down-regulation of nitrate uptake in the presence of ammonium has been demonstrated for other species in ammonium-dominated systems (Kronzucker, Siddiqi and Glass 1997, Kronzucker, Glass and Siddiqi 1999). It appears from the results of excised root experiments that the combined presence of ammonium, amino acids and high salinities in salt-marsh soils is likely to restrict nitrate uptake and result in a very minor contribution of nitrate to plant nutrition. Amounts of this N source are low in these saline soils in any event (Wilson and Jefferies 1996).

Overall, the results of this study provide evidence that amino acids are an important source of nitrogen for the growth of *P. phryganodes*. Roots of *P. phryganodes* respond rapidly to fluctuations in external nitrogen concentrations and edaphic conditions, and the directions and strengths of these responses on rates of nitrogen uptake differ between the nitrogen sources (Fig. 3.3). Based on the results of excised root experiments, amino acid uptake is likely at its highest relative to ammonium uptake from mid- to late- growing season when soil salinity, soil temperatures and free amino acid concentrations in the soil solution are high. A thorough understanding of the dynamics of both soluble organic and inorganic nitrogen is essential for estimating plant nitrogen availability in Arctic coastal marshes and elsewhere.

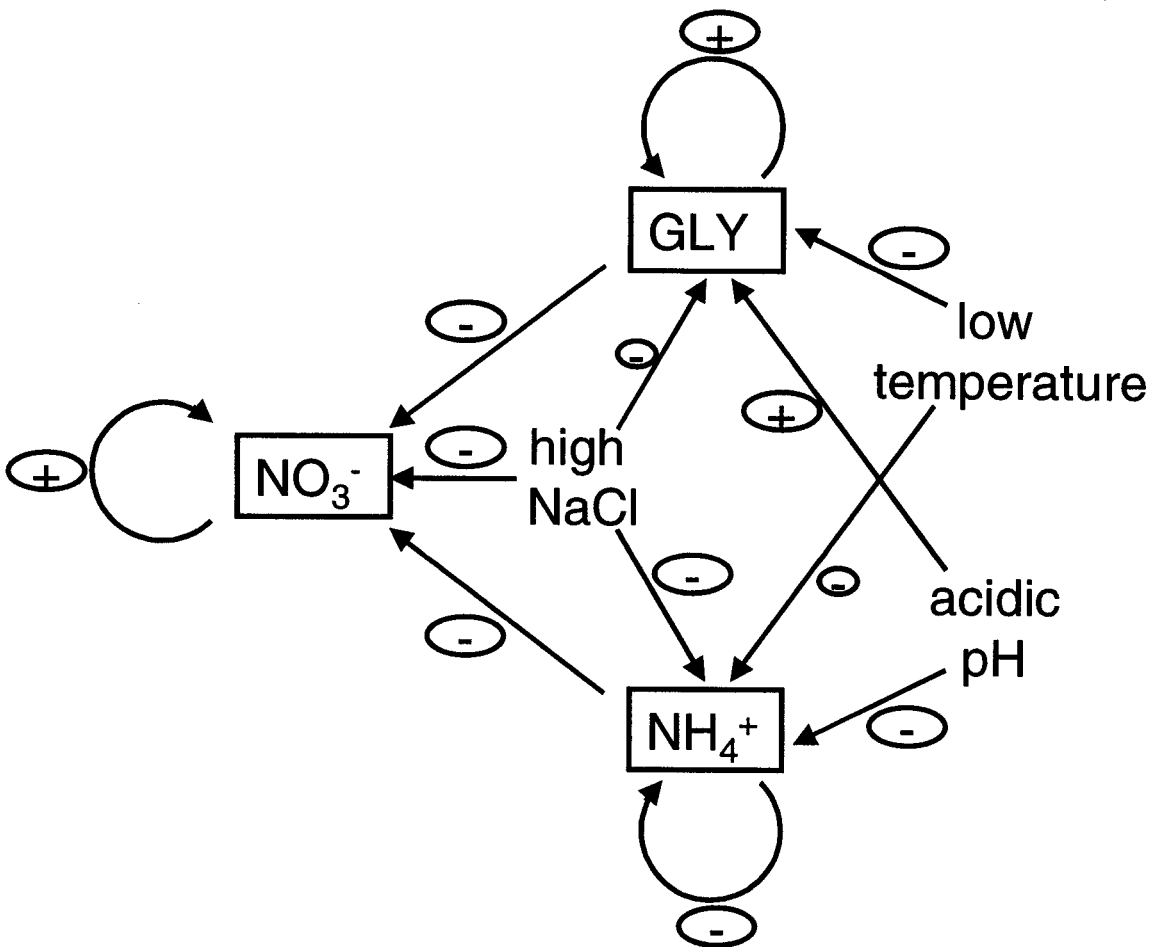

**Fig. 3.3.** Summary of effects high salinity, low temperature, acidic pH and external concentrations of glycine, ammonium and nitrate on rates of uptake of glycine, ammonium and nitrate in *Puccinellia phryganodes*. Plus symbols denote up-regulation and minus symbols denote down-regulation. Smaller ovals indicate relatively low effect. The lack of an arrow indicates that no effect was present, with the exception of the effect of the relative effect of cold temperature on nitrate uptake, which was not tested. A strong negative down-regulation of nitrate uptake under high salinity was assumed.

## **Chapter 4: Plant amino acid uptake, soluble N turnover and microbial biomass dynamics in a grazed Arctic coastal marsh**

### **4.1 Abstract**

The uptake of free amino acids by the grass *Puccinellia phryganodes* was investigated in June and July 2000 and 2001 in soils of an Arctic coastal marsh, where cold temperatures and high salinity limit inorganic nitrogen availability and the availability of soluble organic nitrogen relative to inorganic nitrogen is high. Following the injection of  $^{13}\text{C}^{15}\text{N}$ -amino acid,  $^{15}\text{N}$ -ammonium and  $^{15}\text{N}$ -nitrate tracers into soil, rates of soluble nitrogen turnover and the incorporation of  $^{13}\text{C}$  and  $^{15}\text{N}$  into plant roots and shoots were assessed. Chloroform fumigation-extraction was used to estimate the partitioning of labelled substrates into microbial biomass. Free amino acids turned over rapidly in the soil, with half-lives ranging from 8.2-22.8 h for glycine and 8.9-25.2 h for leucine, compared with ranges of 5.6-14.7 h and 5.6-15.6 h for ammonium and nitrate, respectively.  $^{15}\text{N}$  from both organic and inorganic substrates was incorporated rapidly into plant tissue and the ratio of  $^{13}\text{C}/^{15}\text{N}$  incorporation into plant tissue indicated that at least 5-11% of  $^{13}\text{C}^{15}\text{N}$ -glycine was absorbed intact. Microbial C and N per unit soil volume were 1.7 and 5.4 times higher than corresponding values for plant C and N respectively. Plant incorporation of  $^{15}\text{N}$  tracer was 56%, 83% and 68% (respectively) of the comparable incorporation by soil microorganisms of glycine, ammonium and nitrate ions respectively. These results indicate that *P. phryganodes* can absorb amino acids

intact from the soil despite competition from soil microorganisms, and that free amino acids may contribute substantially to N uptake in this grass.

## 4.2 Introduction

The availability of N in soluble forms that can be taken up by plants limits primary production in most terrestrial ecosystems (Ågren 1985, White 1993). Inorganic N is often the dominant form of N available for plant uptake; however, relatively high concentrations of free amino acids are also present in Arctic, alpine and boreal soils (Chapin, Moilanen and Kielland 1993, Kielland 1995, Raab, Lipson and Monson 1996, 1999, Nordin, Högberg and Näsholm 2001) and in some temperate soils (Mengel 1996, Schulten and Schnitzer 1998, Murphy *et al.* 2000). Many mycorrhizal and non-mycorrhizal plants absorb amino acids rapidly from hydroponic solution (Soldal and Nissen 1978, Schobert and Komor 1987, Kielland 1994, Raab, Lipson and Monson 1996, 1999, Wallenda and Read 1999, Falkengren-Grerup, Månsson and Olsson 2000, Persson and Näsholm 2001, Thornton 2001). Based on soil free amino acid concentrations and root uptake kinetics, it has been proposed that rates of organic N uptake relative to inorganic N uptake may be high in some ecosystems (Chapin, Moilanen and Kielland 1993, Atkin 1996). The direct uptake of free amino acids by plants may have important consequences for N cycling in these systems, as it would allow plants to short-circuit the conventional N cycle and would decouple primary production from rates of N mineralization (Chapin 1995).

Despite evidence that plants take up free amino acids readily from hydroponic solution, it is unclear to what extent amino acids are taken up intact by plants *in situ*,

where roots compete with soil microorganisms for organic N (Owen and Jones 2001). Dual-labelled  $^{13}\text{C}^{15}\text{N}$ - or  $^{14}\text{C}$ -amino acid tracers may be injected into soil in an attempt to detect intact amino acid uptake by roots. Several tracer studies have demonstrated high to moderate  $^{13}\text{C}$ -enrichment as a proportion of  $^{15}\text{N}$ -enrichment in plants, which suggests that substantial fractions of amino acids can be absorbed intact (Lipson and Monson 1998, Näsholm *et al.* 1998, Streeter, Bol and Bardgett 2000, Näsholm, Huss-Danell and Högberg 2000, 2001). In contrast, others have failed to demonstrate substantial  $^{13}\text{C}$ - (or  $^{14}\text{C}$ ) enrichment relative to  $^{15}\text{N}$ -enrichment, which suggests that amino acids were deaminated prior to root uptake and that  $^{15}\text{N}$  was taken up in the inorganic form (Schimel and Chapin 1996, Hodge *et al.* 1998, 1999, 2000, Owen and Jones 2001). Although this large variation in results may be explained in part by differences in experimental conditions and analytical techniques (Näsholm and Persson 2001), it also may reflect variation in the abilities of different plant species to compete for available soil organic N (Kielland 1994, Raab *et al.* 1999, Falkengren-Grerup *et al.* 2000).

Plant amino acid uptake may play an important role in the N cycling of goose-grazed Arctic coastal marshes, where high salinity, in addition to cold temperatures, limits N mineralization and inorganic N uptake (Wilson and Jefferies 1996). However, in general, amino acid turnover in saline terrestrial systems and their uptake by plants have not been examined. In goose-grazed coastal marshes, the regrowth of grass following defoliation by geese is dependent on droppings, yet estimated amounts of soluble inorganic nitrogen in faeces are inadequate in some cases to account for N sequestered in new plant growth (Hik, Sadul and Jefferies 1991). Based on bulk soil solution concentrations and the results of a continuous flow nutrient addition experiment, amino

acid uptake by the salt-marsh grass *Puccinellia phryganodes* was estimated to be as high as 57% that of the uptake of ammonium ions (Chapter 2). Free amino acids may provide an important source of nitrogen for the regrowth of salt-marsh plants grazed by geese, provided that the plants can compete effectively with soil microorganisms for amino acids *in situ*.

In the present study, heavy-isotope tracers were used to characterize the partitioning of soluble organic and inorganic N between plants and soil microorganisms in soils of an Arctic salt-marsh situated on the south-west Hudson Bay coast. Dual-labelled  $^{13}\text{C}^{15}\text{N}$ -amino acids,  $^{15}\text{N}$ -ammonium and  $^{15}\text{N}$ -nitrate were injected into soil to estimate rates of soil N turnover and to compare rates of intact amino acid and inorganic N uptake by *P. phryganodes*, the dominant goose forage grass. Chloroform fumigation extraction was used to estimate microbial immobilization of N substrates.

## 4.3 Materials and methods

### 4.3.1 Study sites

*In situ* experiments were conducted in a grazed Arctic coastal salt marsh at La Pérouse Bay, Wapusk National Park, located approximately 30 km east of Churchill, Manitoba, Canada (58° 43 N, 94° 26 W), on the south-west coast of Hudson Bay. The marsh can be subdivided into an intertidal zone, that is tidal in late summer and autumn, but not from snow melt until late July in most years, and a supratidal zone that is rarely flooded with sea water. The vegetation of the intertidal marsh is dominated by the grass, *Puccinellia phryganodes* (Trin.) Scribn. and Merr., and the sedge, *Carex subspathacea* Wormskj which form discontinuous swards because of early spring grubbing by lesser

snow geese that leads to sward destruction (Jefferies 1988a,b). Net above-ground production of intact swards has been estimated to be between 100 and 150 g m<sup>-2</sup> year<sup>-1</sup> (Cargill and Jefferies 1984b, Hik and Jefferies 1990). Further inland, the supratidal zone also is dominated in low-lying areas by swards of *P. phryganodes* and *C. subspathacea*, but low shrubs, predominately *Salix brachycarpa* Nutt., and grasses, especially *Festuca rubra* L. and *Calamagrostis deschampsoides* Trin., colonize frost-heave sites.

Nomenclature follows Porsild and Cody (1980).

Soils were classified as Regosolic Static Cryosols (Agriculture Canada Expert Committee on Soil Survey 1987, Wilson and Jefferies 1996). Soils in the intertidal zone have a greyish mineral horizon of marine sediment above which lies the top 1-2 cm that is rich organic material. Soils are often highly reduced ( $E_h$  -50 mV) in spring, especially where they are close to drainage channels (Wilson and Jefferies 1996). In the supratidal marsh, a mineral base is covered by 3-4 cm of dark brown-black highly humified organic material. Over the growing season from late May to late July, mean amino acid concentrations in soil solutions of the intertidal zone range from 32-45  $\mu$ M, while ammonium and nitrate concentrations range from 55-160 and 10-31  $\mu$ M respectively (Chapter 2). Amino acids present at high concentrations are alanine, proline, glutamic acid, leucine, tyrosine, gamma amino-butyric acid and glycine. Soil pH averages 7.12 +/- 0.04 (n=24) in both the intertidal and supratidal marshes. The salinity of extracted soil solutions can rise to as high as 40 g Na<sup>+</sup>/L in late summer in intertidal sites devoid or nearly devoid of vegetation. However, beneath intact swards the salinity of the bulk soil solution in summer is at or less than that of sea water (c.12 g Na<sup>+</sup> L<sup>-1</sup>) (Srivastava and Jefferies 1995, Wilson and Jefferies 1996). Turnover and uptake experiments were

**Table 4.1 . Summary of temperature, soil moisture and plant biomass data (n=6) for dates on which N turnover and uptake experiments were conducted in the intertidal marshes at La Pérouse Bay, Manitoba .**

	2000		2001					
	25 June	14 July	17 June	9 July				
soil temperature during incubation ( °C)	2.4 - 5.6	6.9 - 11.3	2.9 - 7.1	4.1 - 5.4				
air temperature during incubation ( °C)	1.9 - 7.4	12.3 - 23.0	5.2 - 11.8	5.4 - 7.9				
degree days since 1 June*	147	371	194	471				
	intertidal mean (s.e.)	supratidal mean (s.e.)	intertidal mean (s.e.)	supratidal mean (s.e.)	intertidal mean (s.e.)	supratidal mean (s.e.)		
soil moisture (% by dry mass)	54.8 (0.6)	63.6 (1.3)	49.7 (1.3)	58.2 (0.7)	53.0 (1.3)	63.0 (0.8)	53.9 (1.1)	60 (2.2)
root biomass (g m <sup>2</sup> of soil)	n.a.	n.a.	94.7 (6.6)	73.4 (11.0)	n.a.	n.a.	198.6 (43.7)	96.9 (15.5)
shoot biomass (g m <sup>2</sup> of soil)	n.a.	n.a.	142.2 (12.8)	91.5 (11.0)	n.a.	n.a.	141.6 (18.4)	68.4 (7.5)

\* degree days calculated by taking the sum of daily temperature maxima since 1 June

conducted in two contrasting years, 2000 and 2001, that were characterized by late and early springs respectively. Temperature, soil moisture and plant biomass data that correspond with the sampling dates are provided in Table 4.1.

#### 4.3.2 N turnover

Pairs of soil cores were collected from 3 intertidal and 3 supratidal sites on 25 June and 12 July 2000, and 17 June and 9 July 2001. Cores were collected using 7.6 cm diameter X 6 cm deep galvanized steel rings, then wrapped in plastic film and transported back to a field laboratory. All cores were injected in a 7-point hexagonal pattern with a total of 7 ml of 1 mM  $^{15}\text{N}$  solution ( $^{15}\text{NH}_4\text{Cl}$ ,  $\text{K}^{15}\text{NO}_3$ ,  $^{13}\text{C}^{15}\text{N}$ -glycine or  $^{15}\text{N}$ -leucine) using 15 cm double-sideport spinal syringes (Popper and Sons, Hyde Park, New York). Syringes were drawn up while injecting to evenly distribute the solution at all depths of the core. Immediately, soil from one core from each pair was mixed and a 15 g subsample was extracted in 75 ml of chilled 2 M KCl on ice for 1 h, then filtered through Whatman GF/A filter paper and frozen. A second subsample was collected to determine the fw/dw ratio. The second core from each pair was incubated at soil temperature for 24 hours prior to mixing and extraction as outlined above (6 h incubations were also run on 12 July 2000). A 24 h incubation period was selected to minimize respiratory losses of  $\text{CO}_2$  from plant material.

$^{15}\text{N}$  was recovered from KCl extracts using a modified ammonium diffusion technique after Stark and Hart (1996). Ammonium traps were constructed by pipetting 5 • M of 2.5 M  $\text{KHSO}_4$  onto 7 mm disks of N-leached Whatman No. 1 filter paper and by encasing the disks in folded strips of PTFE thread sealing tape. For each sample, one trap

and 0.2 g MgO were added to 8 ml of KCl extract and 20 ml of a 0.14 M NH<sub>4</sub>Cl / 2 M KCl carrier solution and placed in sealed 75 ml plastic specimen containers. Solutions were mixed daily and diffused for 6 days, after which the traps were dried and analysed for <sup>15</sup>N/<sup>14</sup>N ratio and N content using an Isochrom continuous flow stable isotope mass spectrometer (Micromass) coupled to a Carla Erba elemental analyser (CHNS-O EA1108). Isotopic analyses were performed by the University of Waterloo Environmental Isotope Laboratory, Waterloo, Ontario.

Nitrate (<sup>15</sup>NO<sub>3</sub>) was recovered from KCl extracts using an extension of the NH<sub>4</sub> diffusion method. First, 0.2 g MgO was added to open containers of extract to volatilize NH<sub>4</sub>. After 6 days, containers were sealed and provided with ammonium traps and 0.4 g Devarda's alloy to reduce NO<sub>3</sub> to NH<sub>4</sub>. <sup>15</sup>N-amino acids were recovered by adding 0.4 g of Devarda's alloy to alkaline persulphate oxidations of KCl extracts (see below) and by reducing NO<sub>3</sub> to NH<sub>4</sub> to determine total <sup>15</sup>N (10 M NaOH was substituted for MgO as a base). <sup>15</sup>NH<sub>4</sub> and <sup>15</sup>NO<sub>3</sub> were subtracted from this total to give an estimate of <sup>15</sup>N amino acid. Blanks, N standards and diffused and non-diffused <sup>15</sup>N standards were included for all diffusion analyses (the coefficient of variation of standards was < 3%).

### 4.3.3 In situ uptake

Roots and shoots of *P. phryganodes* were collected from <sup>15</sup>NH<sub>4</sub>, <sup>15</sup>NO<sub>3</sub> and <sup>13</sup>C<sup>15</sup>N-glycine-injected cores used in the N turnover experiments on 12 July 2000 and 9 July 2001. Plant materials were washed three times in 0.5 mM CaCl<sub>2</sub>, dried, ground, then analysed for <sup>13</sup>C and <sup>15</sup>N content by mass spectrometry. Separate subsamples were

collected from each core to determine the dry weight of roots and shoots per unit area of soil core.

#### **4.3.4 Microbial biomass and $^{15}\text{N}$ incorporation**

Microbial C and N were estimated on 6 June, 4 July and 26 July 2001 using a modified chloroform-fumigation extraction method developed for wetland soils (Witt *et al.* 2000). Two soil cores were collected from each of the 3 intertidal and 3 supratidal sites used in the N turnover experiment. Two 70 g subsamples were collected from each core and cleared of live plant material. The first subsample was immediately extracted in 140 ml of 0.5 M  $\text{K}_2\text{SO}_4$  for 1 h, filtered through Whatman GF/A filter paper, then frozen. The second subsample was mixed in a sealed 250 ml glass Schott bottle with 2 ml of ethanol-free chloroform. Following incubation in the dark at room temperature for 24 h, the bottles were opened and allowed to evaporate for 30 min, then extracted as described above.

Total extractable N was measured following alkaline persulphate oxidation as described by Cabrera and Beare (1993), followed by analysis for nitrate. Nitrate concentrations were determined colorimetrically using an auto analyser following reaction with Marshall's reagent after reduction to nitrite (Pulse Instrumentation Ltd. Saskatoon, Saskatchewan). Cadmium was used to reduce nitrate to nitrite (Keeney and Nelson 1982).

Extractable C was determined using a dichromate method as described by Nelson and Sommers (1996). Soil extracts (1 ml) were pipetted into boiling tubes and treated with 1 ml of 0.07 M  $\text{K}_2\text{Cr}_2\text{O}_7$ , 2 ml of 98%  $\text{H}_2\text{SO}_4$ , and 1 ml of 88%  $\text{H}_3\text{PO}_4$ . Samples

were mixed and digested at 150 °C for 30 min. After cooling, samples were titrated with 0.01 M  $\text{Fe}(\text{NH}_4)_2(\text{SO}_4)_2 \cdot 6\text{H}_2\text{O}$  in 0.4 M  $\text{H}_2\text{SO}_4$  using 120  $\mu\text{l}$  of 4.7 mM N-phenylanthranilic acid and 0.01 M of  $\text{Na}_2\text{CO}_3$  as an indicator. A glucose standard was used for calibration and values were adjusted for  $\text{Fe}^{2+}$  content (which interferes with the dichromate method), which was measured using the phenanthroline method (Loeppert and Inskeep 1996). Microbial C and N were also determined for N turnover cores injected with and  $^{13}\text{C}^{15}\text{N}$ -glycine on 9 July 2001. Excess  $^{15}\text{N}$  content in fumigated samples was determined following alkaline persulphate oxidation.

#### 4.3.5 Data analyses

For diffused samples,  $^{15}\text{N}$  enrichments were blank corrected using an isotope dilution equation that does not assume complete recovery (Stark and Hart 1996) (a minimum of 97%  $\text{NH}_4$  and 70 %  $\text{NO}_3$  were recovered, respectively). Half-lives of  $^{15}\text{N}$  loss were estimated based on concentrations of  $^{15}\text{N}$  in the extractable fraction of the soil at 0 and 24 h. Tracer incorporation into roots and shoots was estimated by subtracting background enrichment in control samples from the total enrichment present in test samples. Extractable microbial C and N were determined by subtracting non-fumigated soil concentrations from those of fumigated soil. Correction factors of 2.64 and 2.22 were used to estimate total microbial C and N from extractable C and N, respectively (Vance, Brooks and Jenkinson 1987, Witt *et al.* 2000). For dependent variables, site means were compared using ANOVA followed by Tukey's multiple comparison tests to resolve pair-wise group differences. Half-life data were  $\log_{10}$ -transformed prior to analysis to improve normality.

#### 4.4 Results

51-87% of  $^{15}\text{N}$  glycine, 48-85% of  $^{15}\text{N}$  leucine, 68-95% of  $^{15}\text{N}$ -ammonium and 62-95% of  $^{15}\text{N}$ -nitrate was removed from the soil solution over 24 h. In general, rates of ammonium turnover was most rapid, followed by rates of nitrate and amino acid turnover (Fig. 4.1). Rates of N turnover were comparable for incubations of 6 and 24 h (not shown). Turnover of  $^{15}\text{N}$  substrates was slowest on 25 June, 2000, the coldest day tested (Table 4.1).  $^{15}\text{N}$  from ammonium, nitrate and glycine was incorporated equally rapidly into plant roots and less rapidly into plant shoots, where incorporation of  $^{15}\text{N}$  from ammonium was highest (Fig. 4.2). Significant  $^{13}\text{C}$  enrichment was present in roots exposed to  $^{13}\text{C}^{15}\text{N}$ -glycine, and  $^{13}\text{C}$  as a percentage of  $^{15}\text{N}$  enrichment was 5% in 2000 and 11% in 2001.

Extractable microbial C and N and the C/N ratio were generally higher in intertidal sites than in supratidal sites (Fig. 4.3). Extractable microbial C and N increased during the growing season, although this increase was delayed for intertidal sites. On 9 July, 2001, extractable microbial C and N per unit soil volume were 1.7 and 5.4 times higher than root C and N, respectively. Microbial  $^{15}\text{N}$  enrichment did not differ significantly among treatments (Fig. 4.2). On average, from 17-29% of  $^{15}\text{N}$  injected into soil cores was recovered in plant tissue, from 28-34% was recovered in microbial N and from 11-29% remained in the soil solution (Fig. 4.4). Approximately 25% of added label was unaccounted for (not shown).

**Fig. 4.1.** Half-lives of  $^{15}\text{N}$  turnover for  $^{15}\text{N}$ -glycine,  $^{15}\text{N}$ -leucine,  $^{15}\text{NH}_4\text{Cl}$  and  $\text{K}^{15}\text{NO}_3$  injected into soil cores collected from a) the intertidal zone and b) the supratidal zone at La Pérouse Bay, Manitoba, on 25 June and 12 July, 2000 and 17 June and 9 July, 2001. Bar and lines represent mean and standard error, respectively ( $n=3$ ). Common lower case letters denote a lack of a significant difference between soluble nitrogen species within a given sampling date (Tukey's HSD test).

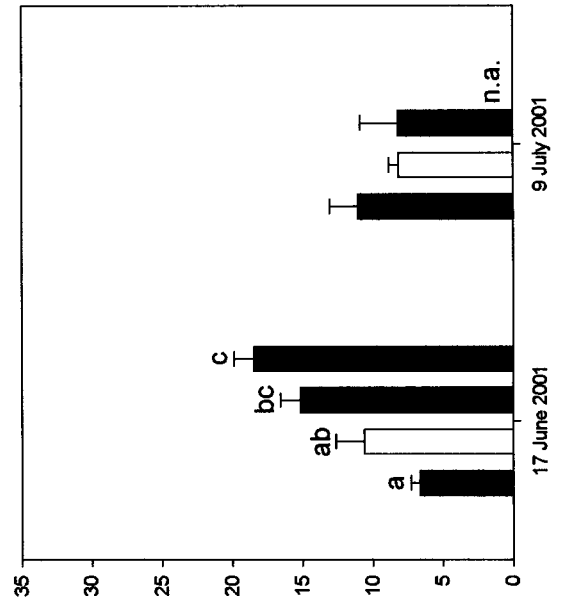
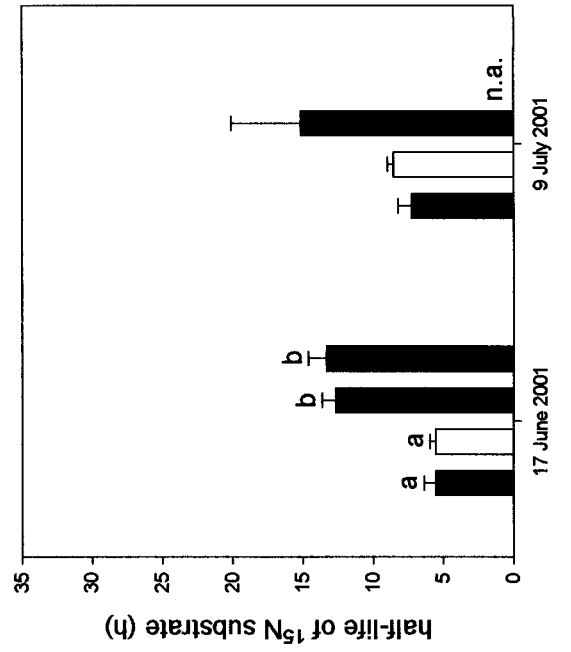
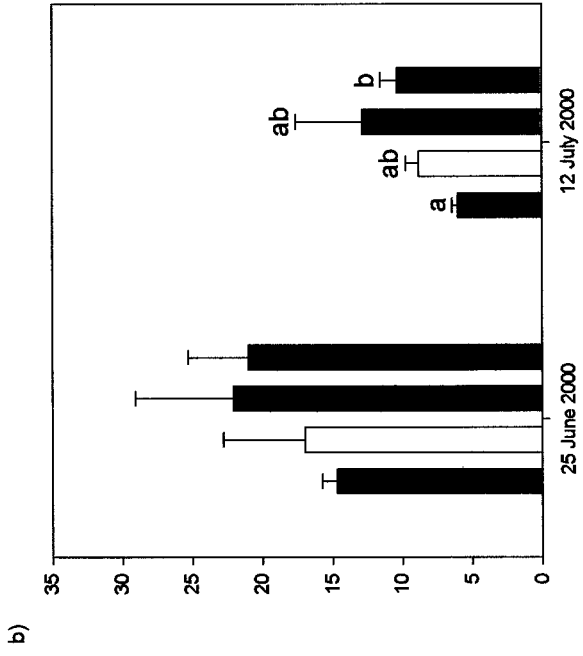
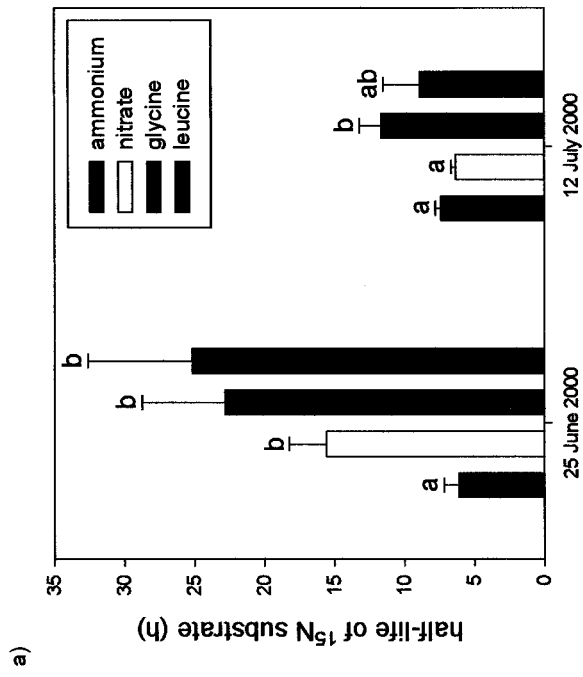

**Fig. 4.2.** Incorporation after 24 h of a)  $^{13}\text{C}$  into roots of *P. phryganodes*, b)  $^{15}\text{N}$  into shoots of *P. phryganodes*, c)  $^{15}\text{N}$  into roots of *P. phryganodes* and d)  $^{15}\text{N}$  into microbial biomass following injection of  $^{13}\text{C}^{15}\text{N}$ -glycine,  $^{15}\text{NH}_4\text{Cl}$  and  $\text{K}^{15}\text{NO}_3$  into soil cores from coastal marshes at La Pérouse Bay, Manitoba on 14 July, 2000 and 9 July, 2001. Bar and lines represent mean and standard error, respectively (n=6, data are averaged over intertidal and supratidal sites). Common lower case letters denote a lack of a significant different between soluble nitrogen species within a given sampling date (Tukey's HSD test).

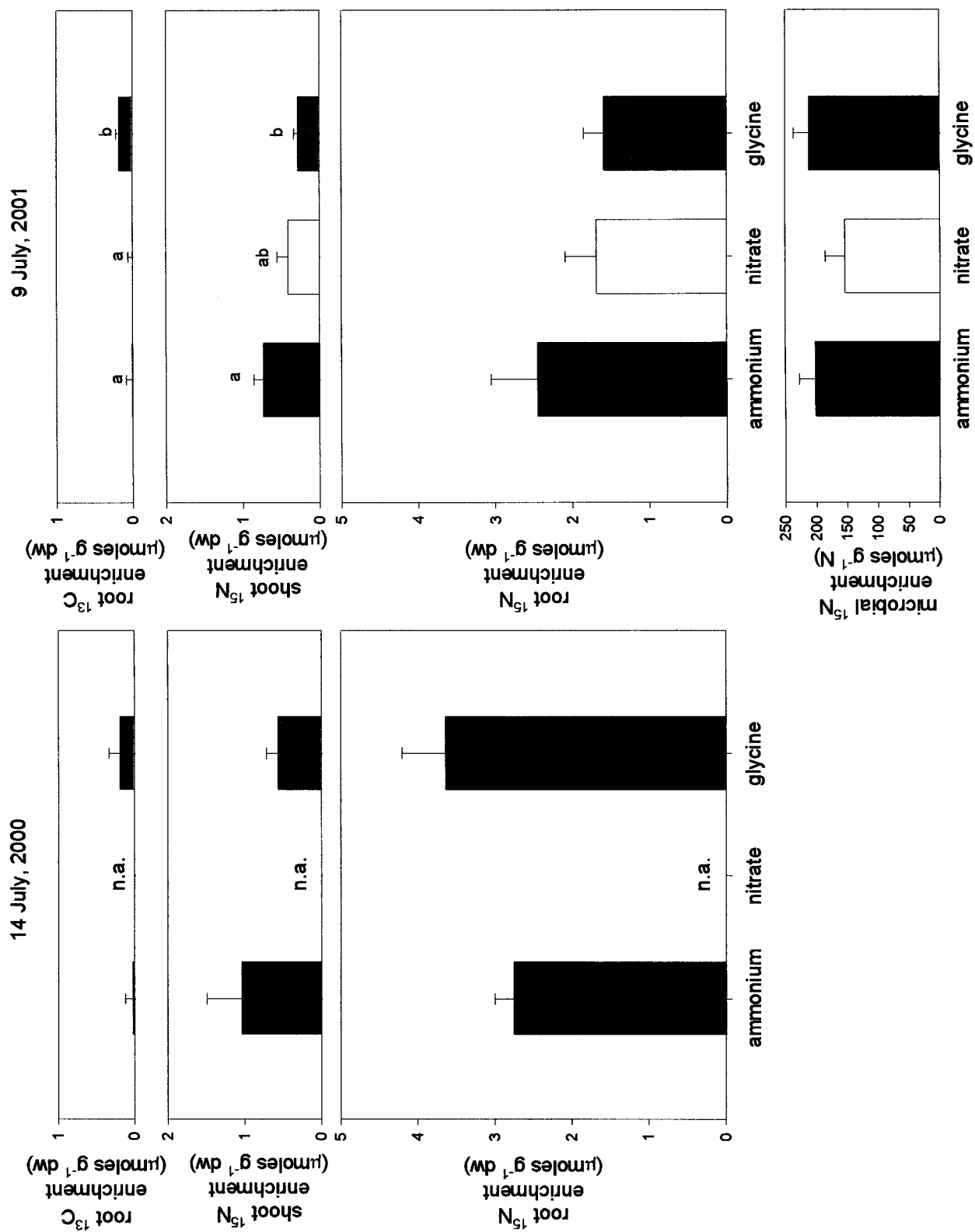

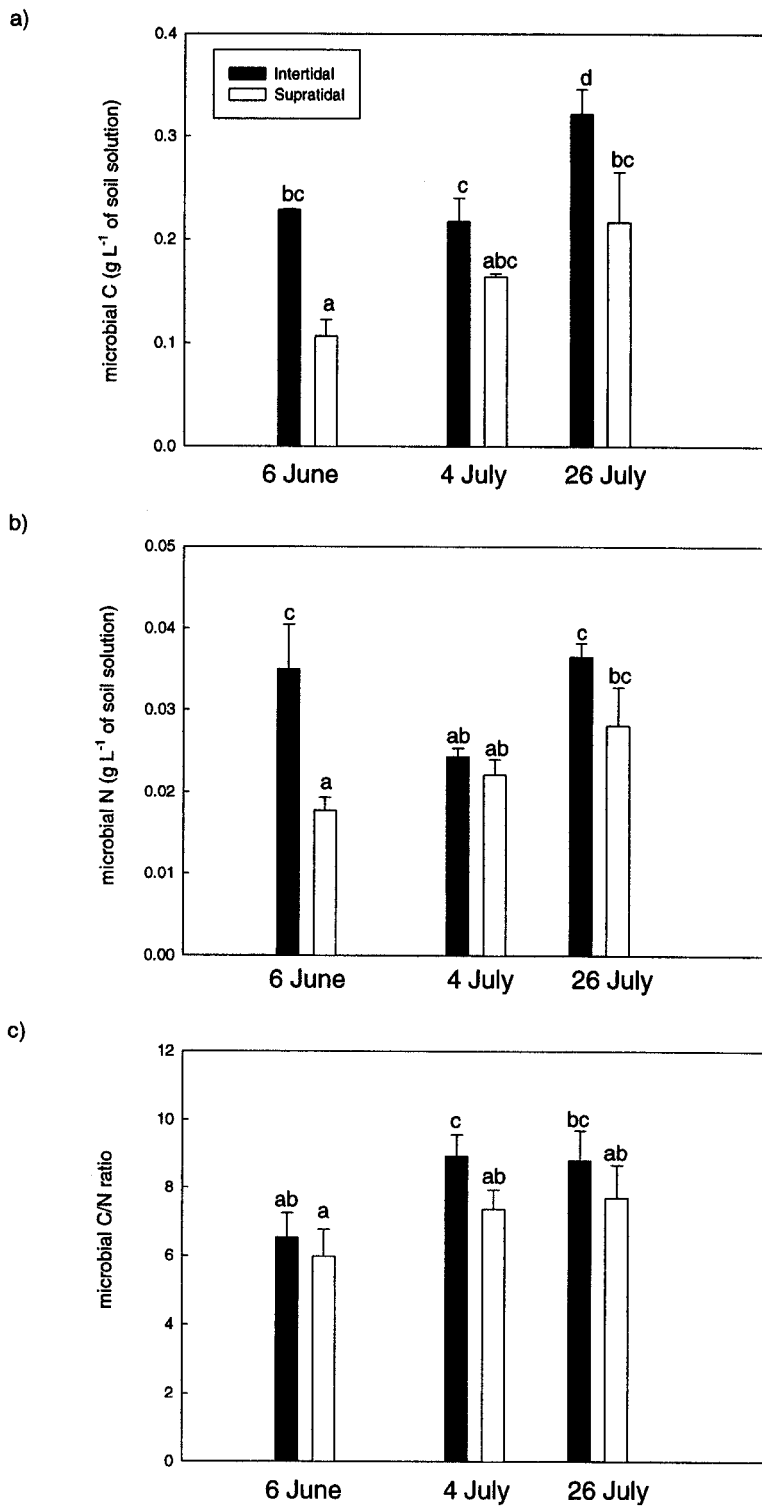

Fig. 4.3. a) Extractable microbial C, b) extractable microbial N and c) C/N ratio of microbial extracts of soil cores on 6 June, 4 July and 26 July, 2001. Bar and lines represent mean and standard error, respectively (n=3). Common lower case letters denote a lack of a significant different between soluble nitrogen species within a given sampling date (Tukey's HSD test).

## 4.5 Discussion

Free amino acids turn over rapidly in soil as a result of uptake by microorganisms and plant roots (Lipson *et al.* 2001, Vinolas, Healey and Jones 2001). In Arctic salt-marsh soils, the turnover rates of amino acids were comparable to those of inorganic N, with half-lives ranging from 8.2-22.8 h for glycine and 8.9-25.2 h for leucine, 5.6-14.7 h for  $^{15}\text{N}$ -ammonium and 5.6-15.6 h for  $^{15}\text{N}$ -nitrate. Rates of amino acid turnover were within the range of 1.7-28.7 h reported for the turnover of amino acids in other Arctic, alpine and temperate soils (Hadas *et al.* 1992, Martens and Frankenberger 1993, Kielland 1995, Jones 1999, Lipson *et al.* 2001, Jones and Kielland 2002). Rates of amino acid turnover are expected to vary with changes in soil temperature (Vinolas, Vallejo and Jones 2001). Low temperatures are associated with low plant root and microbial biomass (Fig. 4.3) and low rates of N transport per unit biomass (Jones 1999, Chapter 3). This is consistent with N turnover in salt-marsh soils, which was slowest on 25 June, 2000, the coldest of the four sampling dates. In the late fall and early spring, high soluble N concentrations are observed in salt-marsh soils (Chapter 3). These peaks in soluble nitrogen are likely the result of lower N turnover rates caused by declining temperatures coupled with the release of soluble N from lysed microbial cells and roots during freeze-thaw cycles (Skogland, Lomeland and Goksøyr 1988, Hobbie and Chapin 1996, Lipson and Monson 1998).

In addition to microbial and root uptake, soluble nitrogen is removed from the soil solution as a result of sorption to the soil solid phase (Jones and Hodge 1999). High rates of adsorption are typically observed for cations such as ammonium and acidic amino

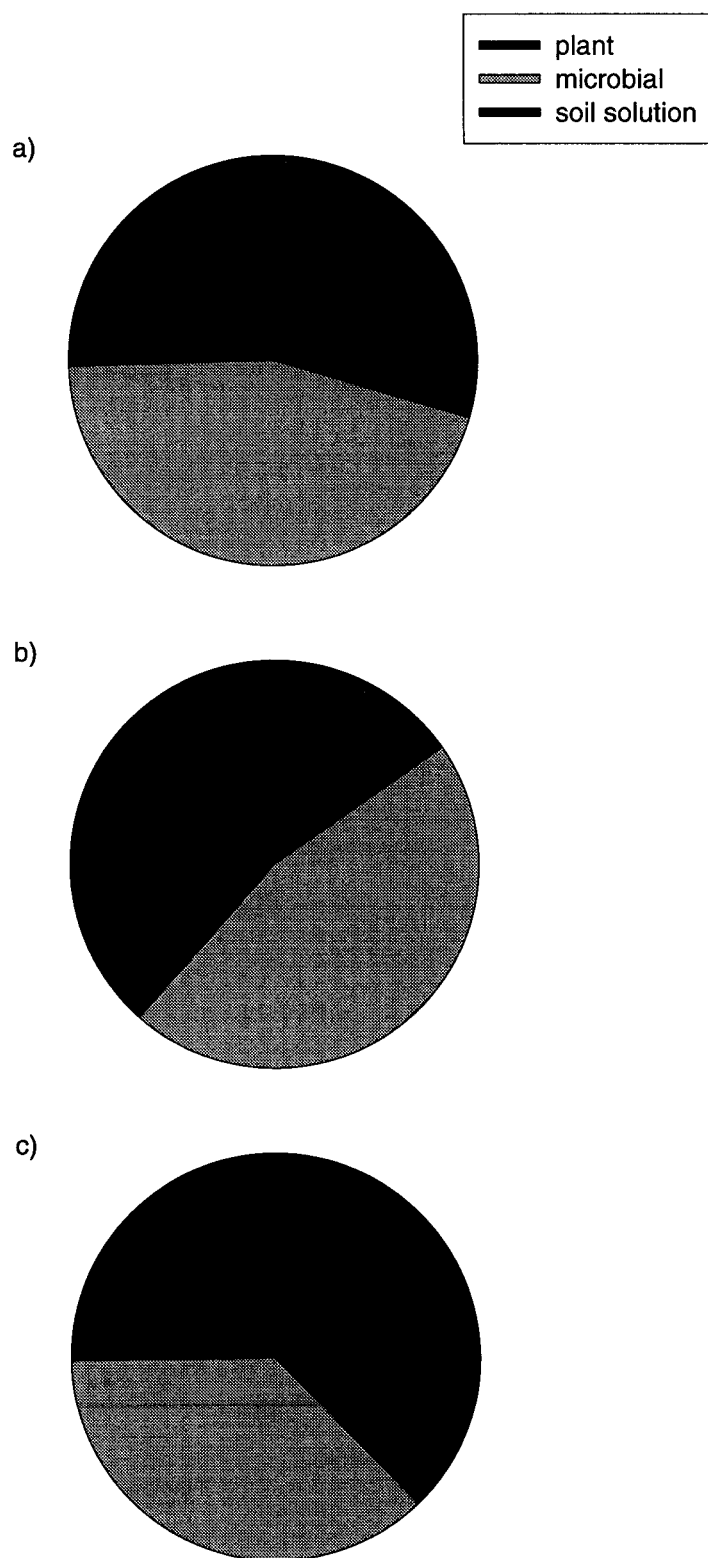

Fig. 4.4. Pie charts displaying the proportion of  $^{15}\text{N}$  partitioned into plant tissue, microbial biomass and the extractable soil fraction for injections of a) glycine, b) ammonium and c) nitrate into soil cores collected from a coastal marsh at La Pérouse Bay, Manitoba, on 9 July, 2001. Data from cores collected from supratidal and intertidal sites are pooled ( $n=6$ ).

acids (Hodge 1999, Jaeger *et al.* 1999). Because of their adsorption to the solid phase, these amino acids and ammonium are typically protected from loss in the soil (Lipson and Monson 1998, Vinolas, Vallejo and Jones 2001). In contrast, neutral and basic amino acids and nitrate are susceptible to losses through runoff and drainage of the soil solution. In saline soils, however, high concentrations of sodium ions and divalent cations such as calcium and magnesium may exclude other monovalent cations from exchange sites (McBride 1989). Therefore, ammonium and acidic amino acids may behave more like anions in salt-marsh soils, resulting in steep depletion zones of ions close to the root surface in the absence of buffering from exchangeable ions attached to the solid phase.

Although  $^{15}\text{N}$  from  $^{13}\text{C}^{15}\text{N}$ -glycine was incorporated as rapidly as  $^{15}\text{N}$  from ammonium and nitrate into roots of *P. phryganodes in situ* (Fig. 4.2), mean  $^{13}\text{C}$  incorporation was only 5% of  $^{15}\text{N}$  incorporation in 2000 and 11% in 2001. This low ratio of  $^{13}\text{C}$  incorporation suggests that a large portion of glycine may have been deaminated prior to uptake of the  $^{15}\text{N}$  fraction. However, it is expected that the ratio of  $^{13}\text{C}/^{15}\text{N}$  incorporation should provide an underestimate of intact amino acid uptake as a result of plant respiratory losses of  $^{13}\text{CO}_2$  following the decarboxylation of amino acids or their breakdown products (Schimel and Chapin 1996). Respiratory  $^{13}\text{C}$  losses were minimized in the present study by employing a relatively short incubation time of 24 h and by utilizing amino acids labelled at the 2-C position which is decarboxylated less rapidly than the 1-C position (Fokin *et al.* 1993). Nevertheless, the carbon in the 2-C position can be respired following deamination and breakdown of the C-skeleton in the Krebs cycle

(Näsholm and Persson 2001). Therefore, some  $^{13}\text{C}$  may have been lost to respiration within 24 h. Even when substantial respiratory losses of  $^{13}\text{C}$  do not occur, isotopic enrichment may be more difficult to detect for  $^{13}\text{C}$  than for  $^{15}\text{N}$  because of the high background concentration of  $^{13}\text{C}$  in plant tissue relative to  $^{15}\text{N}$  (Näsholm and Persson 2001).

The incorporation of  $^{13}\text{C}$  relative to  $^{15}\text{N}$  may also have been low as a result of the deamination of glycine by plant extracellular deaminases at the root surface. Although extracellular deaminases have not been localized on plant roots, they are present on other photosynthetic organisms such as algae (Paul and Cooksey 1979, 1981, DeBusk *et al.* 1981). Hypothetically, their presence on the surface of roots could explain why  $^{13}\text{C}$  incorporation was 50% lower than  $^{15}\text{N}$  incorporation for excised roots of *P. phryganodes* incubated in sterile hydroponic media in short term (20 min)  $^{13}\text{C}^{15}\text{N}$ -glycine uptake experiments (Chapter 3).

The simultaneous recovery of  $^{13}\text{C}$  and  $^{15}\text{N}$  in roots only provides indirect evidence for intact amino acid uptake. For example, if the amino acid glycine is deaminated by extracellular enzymes, both breakdown products ( $^{13}\text{C}$ -glyoxylate and  $^{15}\text{N}$ -ammonium) could be absorbed independently by plant roots (Näsholm and Persson 2001). Nevertheless, results from the use of gas chromatography-mass spectrometry have verified the presence of intact  $^{13}\text{C}^{15}\text{N}$  in roots following uptake by wheat (Näsholm, Huss-Danell and Högberg 2001). In the present study, excess  $^{13}\text{C}$  was recovered in roots of *P. phryganodes* but not in shoots. However, when glycine is used as a tracer, no relation between  $^{13}\text{C}$  and  $^{15}\text{N}$  label is expected in the shoot because transport of N from

roots to shoots occurs in the form of specific amino acids, such as the amides asparagine and glutamine.

Similar to rates of N turnover, microbial biomass increased as the growing season progressed but this increase occurred latest in the intertidal marsh, which indicated that microbial biomass was low for much of the season where soil temperatures were low. This result is consistent with the disruption and loss of microbial biomass as a result of frequent freeze-thaw events in early spring (Skogland *et al.* 1988, Vinolas, Healey and Jones 2001). The C/N ratio was higher in intertidal sites than in supratidal sites, which may indicate a high proportion of fungal biomass relative to bacterial biomass in intertidal soils (Paul and Clark 1989). Estimates of microbial C and N per unit soil volume were respectively 1.7 and 5.4 times greater than corresponding values for plant root C and N. However, the reliability of these estimates is questionable, given that correction factors to convert extractable microbial C and N to total microbial C and N have not been developed specifically for wetland soils (Witt *et al.* 2000).

Although soil microorganisms typically capture a relatively large proportion of the injected substrate in short-term *in situ* tracer experiments (Jackson, Schimel and Firestone 1989, Schimel, Jackson and Firestone 1989, Zak *et al.* 1990, Schimel and Chapin 1996), in some cases, substrate capture by plants and microorganisms is comparable (Lipson and Monson 1998, Norton and Firestone 1996). The latter was mostly true in the present study, where 17, 29 and 19% of the total  $^{15}\text{N}$  injected as glycine, ammonium and nitrate (respectively) were recovered in plant material and 30, 34 and 29% were recovered as microbial N. From 5-38% of  $^{15}\text{N}$  was present in soil solution extracts after 24 h of incubation. Approximately a quarter of  $^{15}\text{N}$  remained unaccounted

for in soil cores. This incomplete recovery of  $^{15}\text{N}$  may reflect error associated with the estimation of total microbial N as discussed above. In addition to potential problems associated with incomplete  $^{15}\text{N}$  recovery, chloroform fumigation-extraction does not distinguish between symbiotic microorganisms and those in competition with plants roots for nitrogen, which may cause an overestimation of microbial uptake and an underestimation of root uptake, particularly in short-term experiments (Lipson and Näsholm 2001). Residual plant root material in fumigated soil also could provide an overestimate of microbial  $^{15}\text{N}$  uptake; however, the effects of root contamination in fumigation-extraction experiments are generally minimal (Witt *et al.* 2000) and in the present study every attempt was made to remove roots prior to fumigation, although fine rootlets may have remained in the soil cores.

Overall, the results of the *in situ* labelling experiments indicate that *P. phryganodes* competes effectively with soil microorganisms for both organic and inorganic N. These results are consistent with the observation that inorganic N derived from mineralization and goose faeces are not adequate to explain the observed regrowth of plants following defoliation by geese (Hik, Sadul and Jefferies 1991). Amino acids likely provide an important source of N to *P. phryganodes* in coastal salt-marshes, where inorganic N is limiting. Given that *P. phryganodes* is a dominant salt-marsh species and the primary forage species of geese, amino acid uptake by this grass has important implications for N cycling in the entire salt-marsh system (see Chapter 5).

## **CHAPTER 5: A model of the dynamics of nitrogen movement in an Arctic salt marsh grazed and grubbed by geese**

### **5.1 Summary**

1. Foraging by increasing numbers of lesser snow geese has led to vegetation loss and exposure of sediments in intertidal marshes on the Hudson Bay coast. Earlier, a smaller population of geese maintained grazing lawns.
2. Data collected during the last 25 years on the nitrogen (N) dynamics of an intertidal marsh were used to construct annual budgets of nitrogen flow under steady-state conditions between sediments, vegetation and geese, where grazing lawns or ungrazed swards occur. These budgets were used as the basis of a simulation model of nitrogen flow under steady-state conditions both in the presence and absence of geese and when goose numbers increase over 50 years.
3. The model represents the flow of combined nitrogen from nitrogen fixation, the major nitrogen input into the system, to the yearly cohort of geese that migrate in autumn, the major output from the system. We also model the process of grubbing that leads to changes in soil and plant nitrogen and a decline in net input of N from fixation.
4. The model satisfactorily simulates the flow of N observed in the field under steady-state conditions at low goose density. However, uptake by the forage grass of both organic and inorganic N and N recycling through faeces are required for the model to produce values of plant and goose productivity that match empirical values.

5. Sensitivity analyses indicate that steady-state conditions are sensitive to changes in parameters that describe nitrogen fixation and goose biology (i.e. inputs and outputs), but they are less sensitive to similar changes in plant parameters.
6. The model shows that an increase in over-winter survival of geese can lead to a large decline in nitrogen input. This decline leads to a collapse of the system that is consistent with field data, which suggests that N dynamics are crucial in regulating the stability of the salt marsh system.

## 5.2 Introduction

Although Arctic plants have the ability to utilize both inorganic and organic forms of soluble soil N (Chapin *et al.* 1993; Kielland 1994, 1995; Atkin 1996, Chapter 2), the nitrogen (N) supply in northern ecosystems limits plant growth (Bliss *et al.* 1973; Van Cleve 1973; Babb and Whitfield 1977, Ulrich and Gersper 1978; Kielland and Chapin 1992). Application of inorganic N to Arctic vegetation results in an increase in net primary production, particularly in graminoid communities (Cargill and Jefferies 1984a; Shaver and Chapin 1986). Without such additions, plant growth rate in these ecosystems is governed ultimately by the low rate of N fixation compared to that in other ecosystems (Chapin and Bledsoe 1992).

In spite of low N fixation, herbivory is widespread in Arctic ecosystems (Jefferies *et al.* 1994). Migratory lesser snow geese (*Anser caerulescens caerulescens*) are herbivores that often breed in Arctic coastal wetlands and forage in intertidal marshes. Plant growth in these marshes is N-limited and not phosphorus-limited, except where nitrogen loading is artificially high (Cargill and Jefferies 1984a). The intertidal marshes

remain N-limited, in spite of the faecal input from lesser snow geese, which accelerates N turnover and plant growth (Bazely and Jefferies 1985; Ruess *et al.* 1989). However, over the long term, input from N fixation is necessary to sustain the annual removal of N by migrating geese (Bazely and Jefferies 1989a, Wilson 1993).

In the last two decades, the mid-continent North American population of lesser snow geese has increased in numbers at about 7 % per annum (Abraham and Jefferies 1997). This increase is probably linked to their use of agricultural crops as a food source on the wintering grounds and flyways (Abraham and Jefferies 1997; Jefferies, Henry and Abraham 2002), which has resulted in a rise in winter survival (Francis 2000). The increased densities of breeding and staging birds in marshes on the Hudson Bay coast in spring has led to considerable damage to intertidal vegetation. At present, vegetation in 2500 ha of coastal marsh in the vicinity of La Pérouse Bay has been lost or severely damaged and at present much of the surface sediment is exposed (Jano *et al.* 1998). Loss of vegetation leads to hypersalinity of sediments (Iacobelli and Jefferies 1991; Srivastava and Jefferies 1996), and depletion of soil organic matter (Wilson 1993; Wilson and Jefferies 1996). The stoloniferous grass, *Puccinellia phryganodes* (Trin) Scribn. and Merr. dominates the remaining intertidal salt-marsh vegetation (Fig 5.1a). The soils of the intertidal marsh have a thin surface Ah horizon (0-3 cm below the surface), in which most of the soil humus is located. The soil surface in the graminoid sward is colonized by cyanobacteria, some of which fix atmospheric N (Bazely and Jefferies 1989a). Geese remove entire plants through the process of grubbing (Fig 5.1b). Where bare sediments occur as a result of grubbing, or where swards are not grazed, fixation rates are lower.

a)

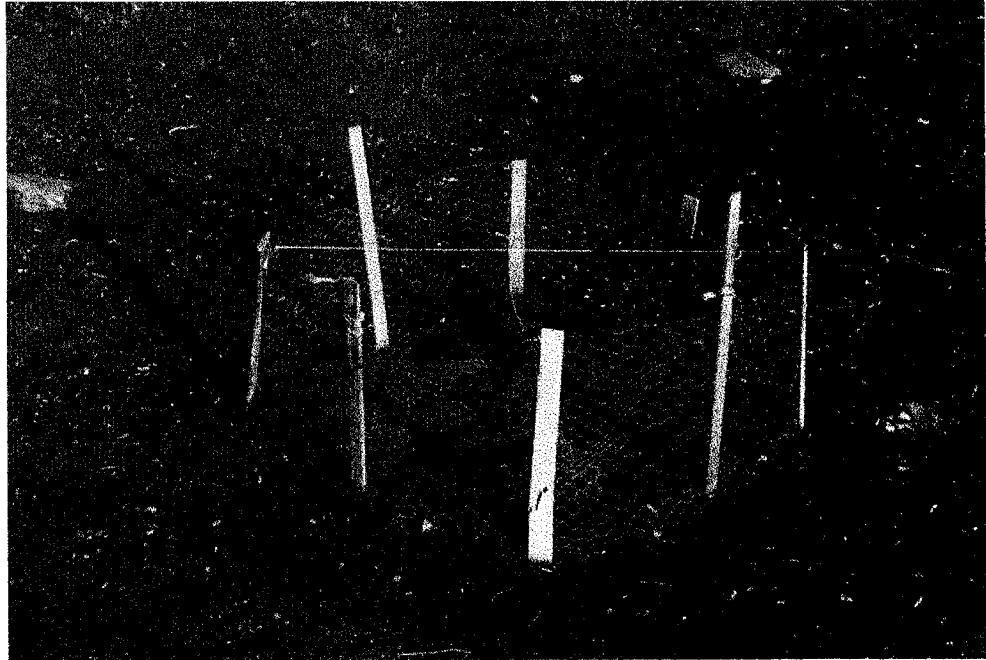

b)



**Fig. 5.1.** a) Representative sward of graminoid vegetation in the intertidal zone of the salt-marsh at La Pérouse Bay, Manitoba. Both goose-grazed (unexclosed) and ungrazed (exclosed) portions of sward are visible. b) Bare sediments exposed as a result of goose grubbing.

In recent years, models have been developed to simulate interactions between climate, biogeochemical cycling and ecosystem functioning, such as the CENTURY model (Parton *et al.* 1967) and the GEM model (Rastetter *et al.* 1991). Other models also have been produced that are often specific to a given ecosystem. Some of them simulate the flow of nitrogen in relation to disturbances that include grazing and fire (Risser and Parton 1982; Seagle *et al.* 1992; Pastor *et al.* 1998), while others are models of grazed swards (e.g. Thornley and Cannel 2000). None of these models is entirely appropriate to simulate the effects of density of geese on the flow of N within grazed Arctic intertidal marshes. In particular, there is a need to model the effects of high goose density, which leads to loss of salt marsh and establishment of an alternative stable state, represented as exposed sediment (Hik *et al.* 1992; Handa *et al.* 2002). Previously, alternative stable state models have emphasized saturation of herbivore feeding (Noy-Meir 1975) or enhancement of nitrogen losses (Rietkerk and van de Koppel 1997) as explanations for multiple stable states and catastrophic behaviour in systems. Many of these models only describe the qualitative behaviour of systems and do not allow for quantitative predictions. Recently, Sundell *et al.* (200N) have described a novel two-patch model of an alternative stable state salt marsh system. Their model is particularly interesting as it focuses on goose behaviour and provides a choice of resource patches, a process we have ignored here. Since the output of their model can lead to clumping of grazers it is clearly relevant in studying the effects of density-dependent processes on resource availability. Their model does not simulate explicitly the movement of N (a limiting resource) and as a consequence is not tied to the physics of the system (e.g. has no time-scale). In their model, the loss of vegetation and soil degradation are the outcome of heavy grazing of

ungrubbed patches of vegetation, which results in hypersalinity and a reduced plant growth rate.

Here we present a simulation model (LPBN) of N flow in a single patch of the Arctic intertidal marsh described above. Annual nitrogen budgets for grazed and ungrazed states of this system, based on empirical data, are used as the basis for the construction of the model. In essence, LPBN simulates changes in these budgets in time. It both interpolates and extrapolates, to provide day-by-day and year-by-year summaries of N compartments and flows. It represents the foraging of geese as a combination of grazing and grubbing. The primary objective of the model is to demonstrate how the disruption of N fixation as a result of low sward area can cause a rapid collapse of the system that is consistent with field data.

### **5.3 Methods**

#### **5.3.1 Site description**

LPBN was developed and its parameter values were chosen to describe N transport in the intertidal salt marsh at La Pérouse Bay, Manitoba, Canada (58°45'N, 93°30'W). The model was based on data from the marsh, which has been extensively studied for more than 25 years (Jefferies 1988; Bazely and Jefferies 1996). It is representative of the extensive intertidal salt marshes that occur along the coast of the Hudson Bay Lowlands - a consequence of isostatic uplift and availability of sediment (Andrews 1973; Kershaw 1976; Martini 1982). However, we emphasize that the model is general in its structure and application.

### 5.3.2 Nitrogen budgets

Data on N pools and fluxes in this marsh were collected between 1978 and 2001 and used to establish a yearly N budget for the system. The budget is based on steady-state grazing conditions where there is neither a net gain nor a net loss of N from the system over the year. Amounts of N in the initial standing crop, in the net primary production of above-ground biomass (NAPP), in plant tissue removed by geese, in faeces, and in the biomass of geese were measured or estimated collectively by Cargill and Jefferies (1984a, b), Bazely and Jefferies (1985), Bazely and Jefferies (1989a,b), Hik and Jefferies (1990) and Wilson (1993). Data of the volatilization of N from faeces are given in Ruess *et al.* (1989). Some N is lost from the system via denitrification (G. Blicher- Mathiesen, unpublished data). Plant litter was calculated as NAPP less that removed by grazing. Amounts of N in rainfall and imported or exported by tides, or lost at spring run-off were measured directly (R.L. Jefferies, unpublished data), or estimated from the elemental composition of Arctic rainfall (Nadelhoffer *et al.* 1992).

N is lost from the system in the bodies of geese that do not return, but on a long-term basis an equal amount is returned by cyanobacterial fixation (Fig 5.2a) (Bazely and Jefferies 1989a, Wilson 1993). Total soil N in the intertidal marsh in 1991 was  $165 \text{ g m}^{-2}$ , by far the largest N pool in the system. In LPBN, the total soil N pool was set at  $85 \text{ g m}^{-2}$ , which is the amount of N present in the top 2.7 cm of soil, where most of the humus and graminoid roots were located. The amount of N mineralized in the N budget ( $2.27 \text{ g m}^{-2}$ ) was approximately half of that measured in 1991 and more than double that measured in the cold, short summer of 1992. Hence the value is a reasonable approximation of mean annual net N mineralization.

A tentative budget for an ungrazed intertidal marsh is shown in Fig 5.2b. The initial standing crop in June (and hence aboveground plant N) is higher than that in the grazed marsh. The rate of N fixation is lower by a factor of 5 as a result of the higher standing crop and increased shading of cyanobacteria. NAPP is reduced by about 20 % compared to grazed sites, because of the absence of faecal recycling.

### **5.3.3 Model description**

Since growth of both plants and geese at the chosen site was N-limited (Cargill and Jefferies 1984a), the entire system was modelled as far as possible on the basis of its nitrogen contents and flows alone. As presented, LPBN does not provide for spatial heterogeneity; it represents a uniform area of indefinite size. Grazer density and grazing process in the steady state are also represented as uniform, both in space and in time, within the limits of a structured calendar describing the model year. The calendar provides a year of 120 days, that represents the 'season', the period from 20 May (goose arrival, Cargill and Jefferies 1984b), to 15 September (the onset of heavy frosts). LPBN is intended to describe

- a) the steady state observed in the past, when N resources used by the geese were regenerated annually,
- b) the quasi-steady state in the absence of grazers (e.g. in exclosures) and
- c) the effects of "over-grazing" brought about by increased numbers of geese described above.

**Fig. 5.2.** Annual N budgets for a) a grazed and b) an ungrazed intertidal salt marsh at La Pérouse Bay, Manitoba. Arrows represent flows of nitrogen in  $\text{g m}^{-2} \text{y}^{-1}$ . The boxes represent pools of N in above-ground biomass and in soil in  $\text{g m}^{-2}$ .

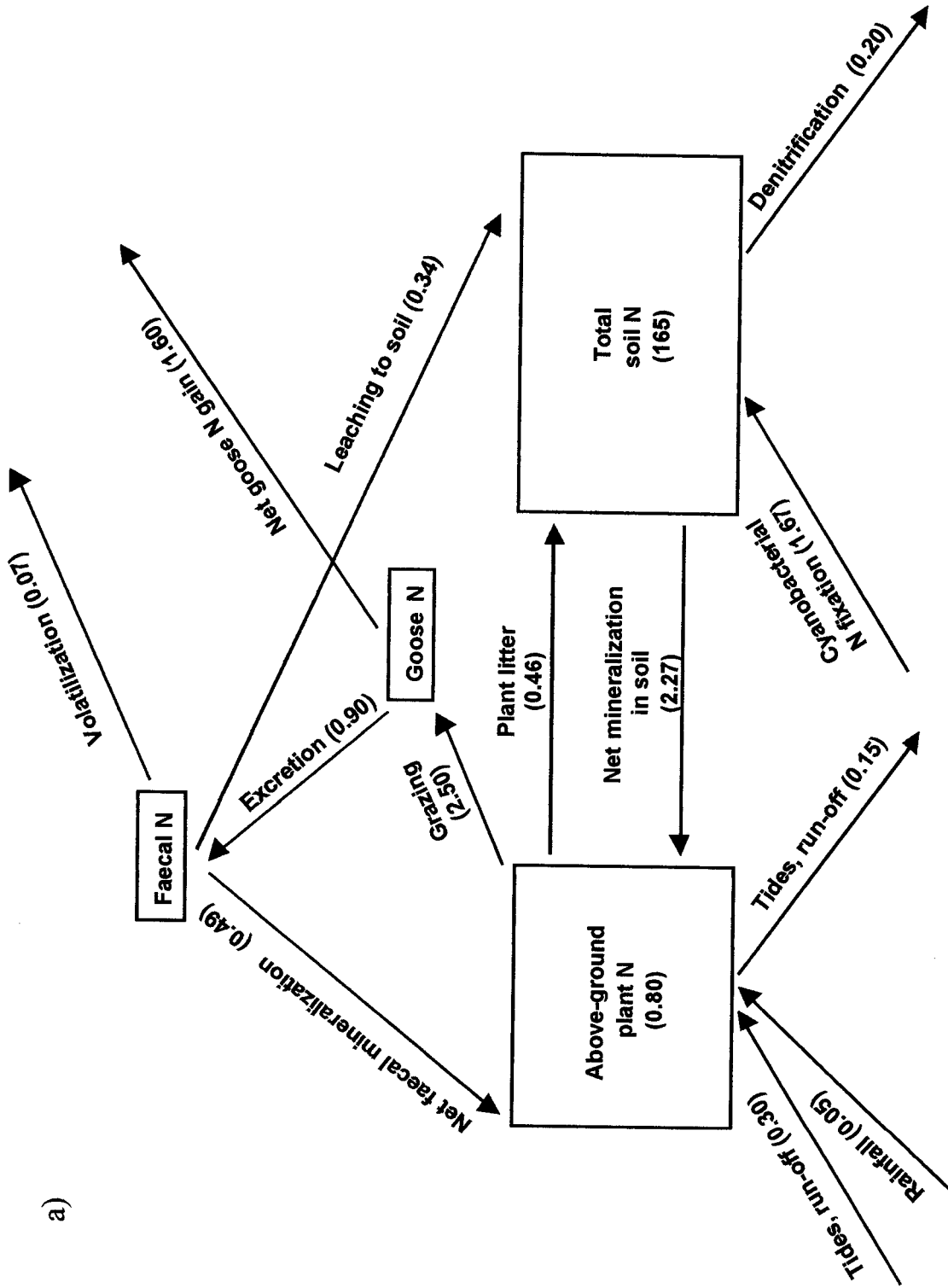

a)

b)

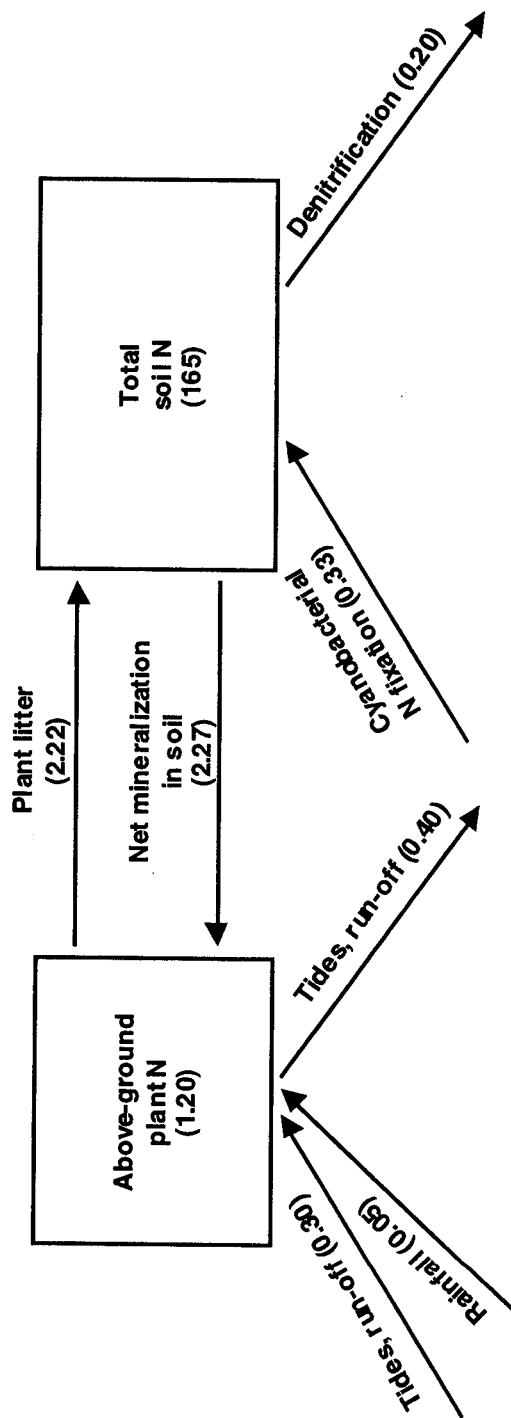

The model is intended to represent both intra-annual and long-term trends in N levels in the system over periods of the order of 1 - 50 years. It is not meant to simulate changes beyond this, as it does not represent the long-term processes brought about by isostatic uplift and vegetation change.

LPBN runs under MATLAB™ 5.1, and was constructed using the SIMULINK™ 2 toolkit (both from The Math Works Inc., Natick, MA, USA). Integration is done with MatLab 5.1's built-in solver ode15s: other built-in solvers also worked well. Although not optimized for speed, it runs very fast on a modern PC. A set of files for defining the model and for setting its parameter values, supervising the runs and presenting the results, is available from N. Alan Walker (alanw@mail.usyd.edu.au).

### **5.3.3.1 The compartments**

LPBN is an 8-state model, representing a system of seven compartments (Fig. 5.3a), open to the outside world. These compartments represent N in:

unavailable organic materials in soil (H)

available organic solutes in the soil solution (O)

available inorganic solutes in the soil solution (I)

plant shoots (S)

plant roots, rhizomes and stolons (R)

bodies of geese (G)

goose faeces (F)

A further state (Fig. 5.3b) represents sward area (A), the fraction of the area of the modelled site occupied by sward, as opposed to exposed (grubbed) soil. Note that there is

**Fig. 5.3.** a) Flow of N among compartments in the Arctic salt-marsh N transport model. Boxes denote quantities, circles denote inputs and outputs and arrows denote the direction of net N flow. Script text refers to the description of functional relationships in Table 1. b) Gains and losses in sward area. Positive (+) and negative (-) effects on fixation are displayed.

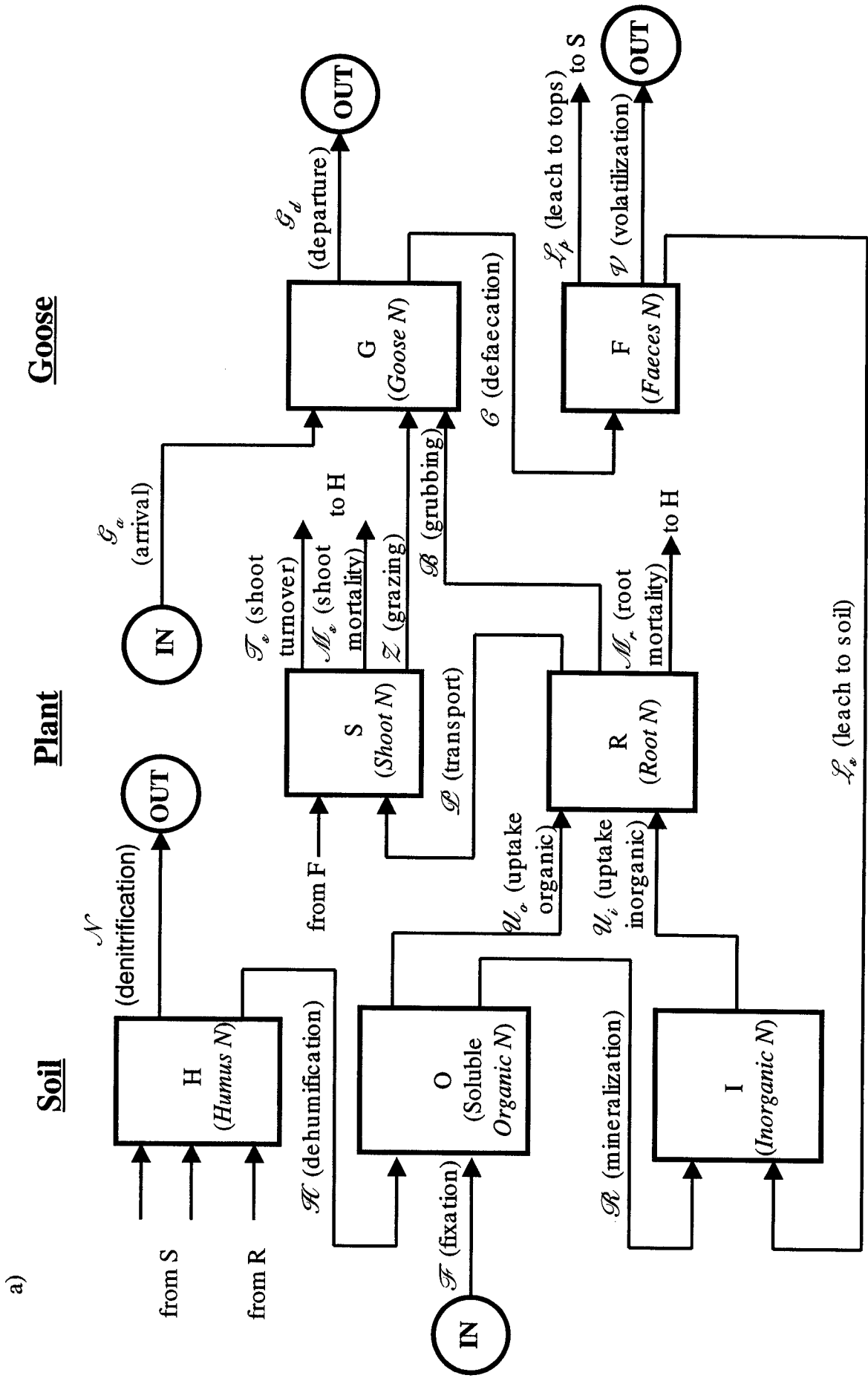

b)

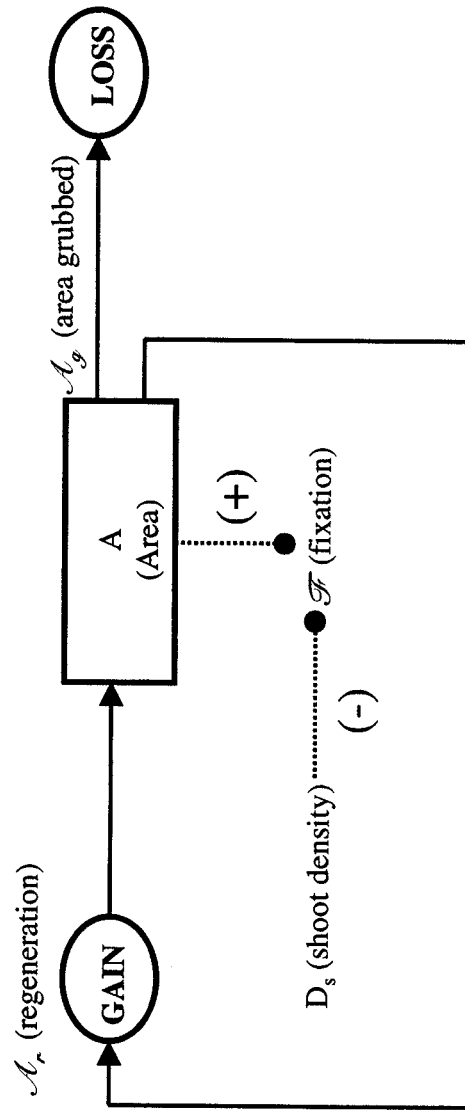

**Table 5.1.** a) State Equations for LPBN. Equations for the model year b) Rate equations for LPBN c) Equations for linking successive integrations (model years, for year t).

a)

$$H \text{ (humus N)} = \int_0^{120} (M_s + M_r + T_s - N - \mathcal{H}) dt$$

$$O \text{ (soluble organic N)} = \int_0^{120} (\mathcal{F} + \mathcal{H} - U_o - R) dt$$

$$I \text{ (inorganic N)} = \int_0^{120} (R + L_s - U_i) dt$$

$$S \text{ (shoot N)} = \int_0^{120} (L_p + \mathcal{P} - T_s - M_s - \mathcal{Z}) dt$$

$$R \text{ (root N)} = \int_0^{120} (U_o + U_i - \mathcal{P} - \mathcal{B} - M_r) dt$$

$$G \text{ (goose N)} = \int_0^{120} (G_a + \mathcal{Z} + \mathcal{B} - G - G_d) dt$$

$$F \text{ (faeces N)} = \int_0^{120} (G - L_s - L_p - \mathcal{V}) dt$$

$$A \text{ (area)} = \int_0^{120} (A_r - A_g) dt$$

b)

$$A_r \text{ (regeneration)} = A e$$

$$A_g \text{ (area grubbed)} = A \mathcal{B} / R$$

$$\mathcal{B} \text{ (grubbing)} = Q_g D_r b$$

$$G \text{ (defaecation)} = G t_g + (\mathcal{B} + \mathcal{Z}) (1 - r)$$

$$\mathcal{F} \text{ (fixation)} = A f_{\max} - S f_s$$

$$G_a \text{ (arrival)} = Q_g$$

$$G_d \text{ (departure)} = G$$

$$\mathcal{H} \text{ (dehumification)} = H h$$

$$\begin{aligned}
\mathcal{L}_p \text{ (leach to shoots)} &= F I_p \\
\mathcal{L}_s \text{ (leach to soil)} &= F I_s \\
\mathcal{M}_r \text{ (root mortality)} &= R t_r \\
\mathcal{M}_s \text{ (shoot mortality)} &= S t_s \\
\mathcal{N} \text{ (denitrification)} &= H n \\
\mathcal{P} \text{ (transport)} &= A I R p \\
\mathcal{R} \text{ (mineralization)} &= O m \\
\mathcal{T}_s \text{ (shoot turnover)} &= S t_p \\
\mathcal{U}_i \text{ (inorganic uptake)} &= R I u_i \\
\mathcal{U}_o \text{ (organic uptake)} &= R O u_o \\
\mathcal{V} \text{ (volatilization)} &= F v \\
\mathcal{Z} \text{ (grazing)} &= Q_g g_{\max} / [1 + (A k_g / s)^3]
\end{aligned}$$

where

$$\begin{aligned}
D_s \text{ (shoot density)} &= S / A \\
D_r \text{ (root density)} &= R / A
\end{aligned}$$

c)

$$\begin{aligned}
\frac{A}{0}^t &= A_{120}^{t-1} \\
\frac{F}{0}^t &= F_{120}^{t-1} \\
\frac{G}{0}^t &= \sigma G_{120}^{t-1} \\
\frac{H}{0}^t &= \gamma H_{120}^{t-1} \\
\frac{I}{0}^t &= \gamma I_{120}^{t-1} \\
\frac{O}{0}^t &= \gamma O_{120}^{t-1} \\
t & \quad t-1
\end{aligned}$$

$$R_0 = \rho R_{120}$$

$$S_0^t = \zeta S_{120}^{t-1}$$

---

no explicit representation of plant or animal numbers or biomass - the compartments represent N density in mass per unit area. The content of each compartment is given by the solution of a differential equation (Table 5.1a) in the rates of flow (Table 5.1b).

### 5.3.3.2 The rates and functional relationships

The model involves many flows, represented as functions of the contents of the relevant compartments (Figs 5.2a,b, Table 5.1b). Few of these functional relationships are known, though the available annual budgets give average annual rates for many of the flows. In the absence of experimental evidence, we have often assumed for simplicity that the flow is proportional to the content of N in the source compartment for that flow.

### 5.3.3.3 Arrival, departure, feeding, excretion

N in geese (G) is increased from zero and decreased to zero by the timed processes of arrival ( $\mathcal{G}_a$ ) and departure ( $\mathcal{G}_d$ ) (Tables 5.1a,b, 5.2). Between these events, the processes of feeding and excretion affect G. Feeding includes grubbing ( $\mathcal{G}$ ) of root N (R) early in the model year and thereafter grazing ( $\mathcal{Z}$ ) on shoot N (S). The grubbing rate, in the absence of a detailed study, is assumed to be proportional to G, and the process is assumed to occur on days 1 - 24 after the geese arrive. There are no studies that define the rate equation for grazing by snow geese, so we have assumed the rate to be

given by a generalized Michaelis-Menten function (Johnson and Parsons 1985). We take the change in grazing rate on day 36 (hatch) to be proportional to the change in number of grazers, rather than to goose  $N$ , on the basis of a study that shows gosling growth rate to be nearly linear in time after hatching (Gadallah and Jefferies 1995). After day 36 (Table 5.2), grazing by goslings and adult females is assumed to increase the grazing rate by a factor of 5. This is based on an average clutch size of approximately four and a gosling summer mortality of about 0.5 (Cooch, Rockwell and Brault 2001). We have for simplicity assumed a clutch of four with one death at hatch, i.e. an equivalent clutch size of three, and a second gosling death after departure, which is included in the over-winter

**Table 5.2.** Timings of processes during the model year. Times in days at which individual processes are changed in rate during the model year of 120 days. Processes not listed are on at constant rate the whole year. Day 1: goose arrival; Day 24: plant growth; Day 36: hatch; Day 84: departure in autumn.

---

Process	begins:	increases:	decreases:	ends:
$\mathcal{G}_a$ (arrival)	1			7
$\mathcal{G}_d$ (departure)	83			85
$\mathcal{Z}$ (grazing)	24	36		83
$\mathcal{B}$ (grubbing)	1			24
$\mathcal{P}$ (transport)	24		84	120
$\mathcal{U}_i$ and $\mathcal{U}_o$ (uptake)	24		84	120
$\mathcal{T}_s$ and $\mathcal{M}_s$ (death of shoots)		whole year and over-winter		
loss of soil N*		over-winter		

---

\* due to loss of sward area

---

mortality. The parameter of over-winter goose survival ( $\sigma$ ) is multiplied by departing goose N on day 120 ( $G_{120}$ ) in order to calculate the initial G on arrival in the following model year (Table 5.1c). The excretion rate ( $\mathcal{E}$ ) is the sum of ingested N ( $\mathcal{I} + \mathcal{Z}$ ) not retained by digestion and the goose protein turnover rate ( $t_p$ ). The rate of ingested N retention is proportional to the rate of ingestion and that of N turned over is proportional to G. Retention ( $r$ ) is set at 0.67, and  $t_p$  was estimated from data for Barnacle geese (Prop and Black, 1997), from the intercept of their linear regression of excretion against ingestion rates.

#### 5.3.3.4 Volatilization, leaching

Constant daily fractions of faecal N (F) are either volatilized ( $\mathcal{V}$ ), or leached into the soil ( $\mathcal{L}$ ) and plant compartments ( $\mathcal{P}$ ). When sward area is  $< 1$  as a result of grubbing, all faecal N is assumed to land on the area of the intact sward.

#### 5.3.3.5 Root and shoot death, denitrification, dehumification, mineralization

Humus N (H) increases as a result of the daily turnover of S and year end mortality of S and R, and decreases as a result of denitrification ( $\mathcal{N}$ ) and dehumification ( $\mathcal{D}$ ), the rates of which are assumed to be proportional to H. Denitrification leads to a loss of N from the system. Dehumification is defined in the model as a flow from H to the available organic N (O). N is lost from O to R as a result of mineralization ( $\mathcal{M}$ ). Mineralization, which is assumed to be proportional to organic N, describes the net effect of the turnover of the soil microbial N pool, a small rapid-cycling pool not explicitly

represented in LPBN. Input of N to inorganic N (I) is the sum of the mineralization rate and leaching of faeces (F).

### 5.3.3.6 Uptake

R increases as a result of uptake from I and O, ( $\mathcal{U}_i$  and  $\mathcal{U}_o$  respectively) at rates proportional to  $R \times I$  or  $R \times O$  respectively. If R can be taken to represent root size, i.e. the explored volume, and all inorganic and organic N in this volume is taken up, these two rate constants should have the same values. Although the uptake kinetics of organic and inorganic N by *Puccinellia* roots saturate at high concentrations, uptake over the range of concentrations present in the soil solution is approximately linear (Chapter 3). S increases by transport ( $\mathcal{E}$ ) and as a result of leaching of F. The sum of these gains in S is used to calculate net above-ground primary production. Uptake and transport processes start on model day 24, slow to 24 % of their initial rates at day 84 (Cargill and Jefferies 1984b) and stop completely on day 120. Over winter, 20 % of S and 80 % of R is carried over on the next year, and the remainder is transferred to H, representing senescence.

### 5.3.3.7 Area grubbing, regeneration

Complete cover by a sward corresponds to a relative sward area (A) of 1.0. When grubbing occurs, there is an immediate proportional loss of R and A. Also, a proportion of area regenerates over time. We assume that soil N is lost through grubbing only if the relevant area lost does not regenerate in the same season. That is, we assume that the fraction of soil N uncovered by grubbing and not reclaimed by sward regeneration in the same growing season is permanently removed during the winter.

### 5.3.3.8 Nitrogen fixation

Higher rates of N fixation are known to occur at lower shoot N, but little is known about the form of the dependence. For simplicity, we have assumed a fixation rate that diminishes linearly with increase of shoot N. The N fixation rate per unit area of sward is multiplied by area to give the net N fixation rate. It is assumed that N fixed on exposed soil is negligible or lost from the system.

### 5.3.4 Parameter values, initial conditions and calibration

The choice of parameter values and initial conditions was based, where possible, on the results of previous studies conducted in the intertidal zone at La Pérouse Bay (Table 5.3). Specifically, rates of N mineralization and denitrification, and pool sizes of H, N and S were obtained from Wilson and Jefferies (1996), N fixation rates and measures of N leaching from faeces were provided by Bazely and Jefferies (1989a) and by Ruess *et al.* (1989). N uptake kinetics and pool sizes for I and O (primarily soluble amino acids) were obtained from Chapter 2. An active soil depth of 2.7 cm was used to convert data in volume-specific units to area-specific units. Grazing rates were taken from Hik and Jefferies (1990), Hik *et al.* (1991) and Gadallah and Jefferies (1995). Unpublished studies of the regeneration of sward by J. McLaren suggest a rate of about 1 cm yr<sup>-1</sup> for regrowth perpendicular to a cut edge. We have arbitrarily assumed for simplicity that grubbing exposes 1 m of edge in each square metre of sward. Thus  $A_e$ , the area regeneration parameter, is about 10<sup>-4</sup> d<sup>-1</sup>. Volatilization data (Ruess *et al.* 1989) were obtained from a study conducted in marshes at La Pérouse Bay.

In the absence of empirical data, other parameter values were derived from non-empirical estimates, carefully examined for plausibility. For example, shoot and root

**Table 5.3.** a) parameters and b) initial conditions for LPBN to match the budgets.

---

a)

$\gamma$	$1 - A_{120}^{t-1} / A_{120}^t$	
$\rho$	$1 - t_r$	
$\sigma$	0.4	
$\zeta$	$1 - t_s$	
$b$	$1.2 \times 10^{-3}$	$\text{g}^{-1}\text{m}^2\text{d}^{-1}$
$e$	$3.0 \times 10^{-4}$	$\text{d}^{-1}$
$f_{\max}$	$3.1 \times 10^{-2}$	$\text{g}^{-1}\text{m}^2\text{d}^{-1}$
$f_s$	$3.0 \times 10^{-2}$	$\text{d}^{-1}$
$g_{\max}$	$7.8 \times 10^{-2}$	$\text{d}^{-1}$
$h$	$2.0 \times 10^{-4}$	$\text{d}^{-1}$
$k_g$	0.35	$\text{g m}^{-2}$
$l_p$	$3.0 \times 10^{-2}$	$\text{d}^{-1}$
$l_s$	$7.0 \times 10^{-2}$	$\text{d}^{-1}$
$m$	$2.0 \times 10^{-2}$	$\text{d}^{-1}$
$n$	$1.6 \times 10^{-5}$	$\text{d}^{-1}$
$p$	$1.2 \times 10^{-2}$	$\text{d}^{-1}$
$Q_g$	1.0	$\text{g m}^{-2}$
$r$	0.67	
$t_g$	$2.5 \times 10^{-3}$	$\text{d}^{-1}$
$t_p$	$8.0 \times 10^{-3}$	$\text{d}^{-1}$
$t_r$	0.8	
$t_s$	0.2	
$u_i$	$3.0 \times 10^{-2}$	$\text{g}^{-1}\text{m}^2\text{d}^{-1}$
$u_o$	$3.0 \times 10^{-2}$	$\text{g}^{-1}\text{m}^2\text{d}^{-1}$
$v$	$1.0 \times 10^{-3}$	$\text{d}^{-1}$

b)

		grazed	not grazed
$A_0^0$	=	1	1
$F_0^0$	=	0.001 g m <sup>-2</sup>	0
$G_0^0$	=	0	0
$H_0^0$	=	86 g m <sup>-2</sup>	86 g m <sup>-2</sup>
$I_0^0$	=	0.29 g m <sup>-2</sup>	0.18 g m <sup>-2</sup>
$O_0^0$	=	0.42 g m <sup>-2</sup>	0.39 g m <sup>-2</sup>
$R_0^0$	=	3.9 g m <sup>-2</sup>	2.7 g m <sup>-2</sup>
$S_0^0$	=	0.18 g m <sup>-2</sup>	0.30 g m <sup>-2</sup>

---

over-winter survival ( $\zeta$  and  $\rho$ ) were based on the comparison of values of late-season biomass with early-season values. The grubbing rate parameter (b), for which consistent data were not available, was adjusted to allow the regeneration of the sward, expressed on an area basis, to match grubbing losses under steady-state conditions in the presence of geese. The grazing affinity ( $k_g$ ) was set to give a grazing rate near saturation at documented values of S, which seems intuitively reasonable. The power in the equation for  $\mathcal{Z}$  was set at 3 (Johnson and Parsons, 1985), but trials at 1, 2, 3 and 4 showed no large consistent differences. The model's initial conditions and parameter values were adjusted

to reproduce the compartment contents and the annual fluxes given in the empirically derived N budgets (Wilson 1993), under two sets of conditions.

1. In a steady state, in the presence of geese at pre-soil degradation densities of geese, and
2. In an alternate, quasi-steady, state, in the absence of geese, with humus N rising over time (Table 5.4). Over-winter goose survival ( $\sigma$ ) was set at 0.4 for the former, the value at which the population growth is zero if the clutch size is 3 (see above).

**Table 5.4.** Comparison of model output with data from N budgets in the presence and absence of geese (Figs. 5.2a, 5.2b)

annual values (g N m <sup>-2</sup> )	geese present		geese absent	
	N budget	model	N budget	model
net gain in goose N	1.6	1.6	-	-
$\mathcal{Z}$ (grazed) and $\mathcal{B}$ (grubbed)	2.5	3.3	-	-
primary production	3.11	4.0	2.62	2.15
peak S	0.8	0.9	1.2	1.5
peak R	n.a.	4.7	n.a.	2.7
N fixed	1.67	1.84	0.33	0.9

### 5.3.5 Sensitivity analyses

Sensitivity analyses were performed to quantify the relative influence of changes in input parameters and initial conditions on the steady-state output values of net goose N gain, net plant primary production and sward area. Parameter values and initial

conditions were modified independently to correspond to plus or minus ten percent of their values under steady-state goose grazing, and the percent deviations in output relative to the steady-state were plotted over a 50-year time course. A more in-depth sensitivity analysis was performed to explore the effect of goose survival on reduction of sward area. For this analysis, the sward area at the end of the season was plotted over a 50-year time course for 0.02 unit increments of over-winter survival of geese starting at a value of 0.4. The model was also re-parameterized to run under steady-state conditions in the absence of organic N uptake by plants, in order to assess the ability of the model to match empirically derived N budgets under these conditions. In addition, the model was run in the absence of N leaching from faeces in order to assess the contribution of faecal N recycling to the availability of goose forage following grazing.

## **5.4 Results**

### **5.4.1 LPBN - General observations**

The model, like the budgets it was based on, describes a system with a dominant source, N fixation, and a dominant sink, departure of the cohort of geese that hatched in a given year. In any true steady state, these must be equal, i.e. in the steady state, the model describes throughput of N from fixation to the net gain in goose N. There is also a dominant buffer in the system, the humus, which can take up differences in these rates over many decades. On a decadal time-scale, the contents of other soil and plant compartments simply adjust to give the required throughput, at least within the range of stability of the model system. On a time-scale of one to two years, however, the contents of these intermediate compartments are critical in determining the behaviour of the

model. Setting it to represent a steady state requires a number of cycles of adjustment of  $S_0$ ,  $R_0$ ,  $I_0$  and  $O_0$ .

#### 5.4.2 Steady-state simulations

We found, as hoped, that the steady-state annual fluxes between major N pools in the model, with values of 0 or 1.0 g m<sup>-2</sup> for initial goose N ( $Q_g$ ), could be brought into agreement with those in the empirically-derived static budgets for grazed or ungrazed conditions (Table 5.4). G and peak S reached the same values for the model and the budget, although the model over-estimated fixation and seasonal (annual) primary production by 10% and 38% respectively. With  $Q_g$  at 0, the model was qualitatively correct in showing lower fixation and primary production and higher S than the respective values with  $Q_g$  at 1.0. However, the model did overestimate fixation with  $Q_g$  at 0. Intra-annual variation in N pools (Fig. 5.4) was quantitatively consistent with trends typically observed in the field (Cargill and Jefferies 1984b, Bazely and Jefferies 1989a, b). S reached a maximum at day 36, after which it fell to a stable value. After departure, S increased again until the end of the model year. Soil N increased rapidly at the beginning but fell with time. H also declined during the model year, but recovered with the influx of N in plant litter at the end of the year. Intra-annual trends in compartment contents were similar with  $Q_g$  at 0 or 1.0 g m<sup>-2</sup>, except that S increased in the absence of grazing until the end of the year (Fig. 5.4). S in the absence of grazing also differed from that when geese were present. With either value of  $Q_g$ , all compartments were in a steady state from year to year except H, which showed a steady gain in the absence of grazing as reported by Wilson (1993).

**Fig. 5.4.** Intra-annual trends in N compartment sizes for the salt-marsh N transport model a) in the presence of geese and b) in the absence of geese. Some timed seasonal events are noted at the top.

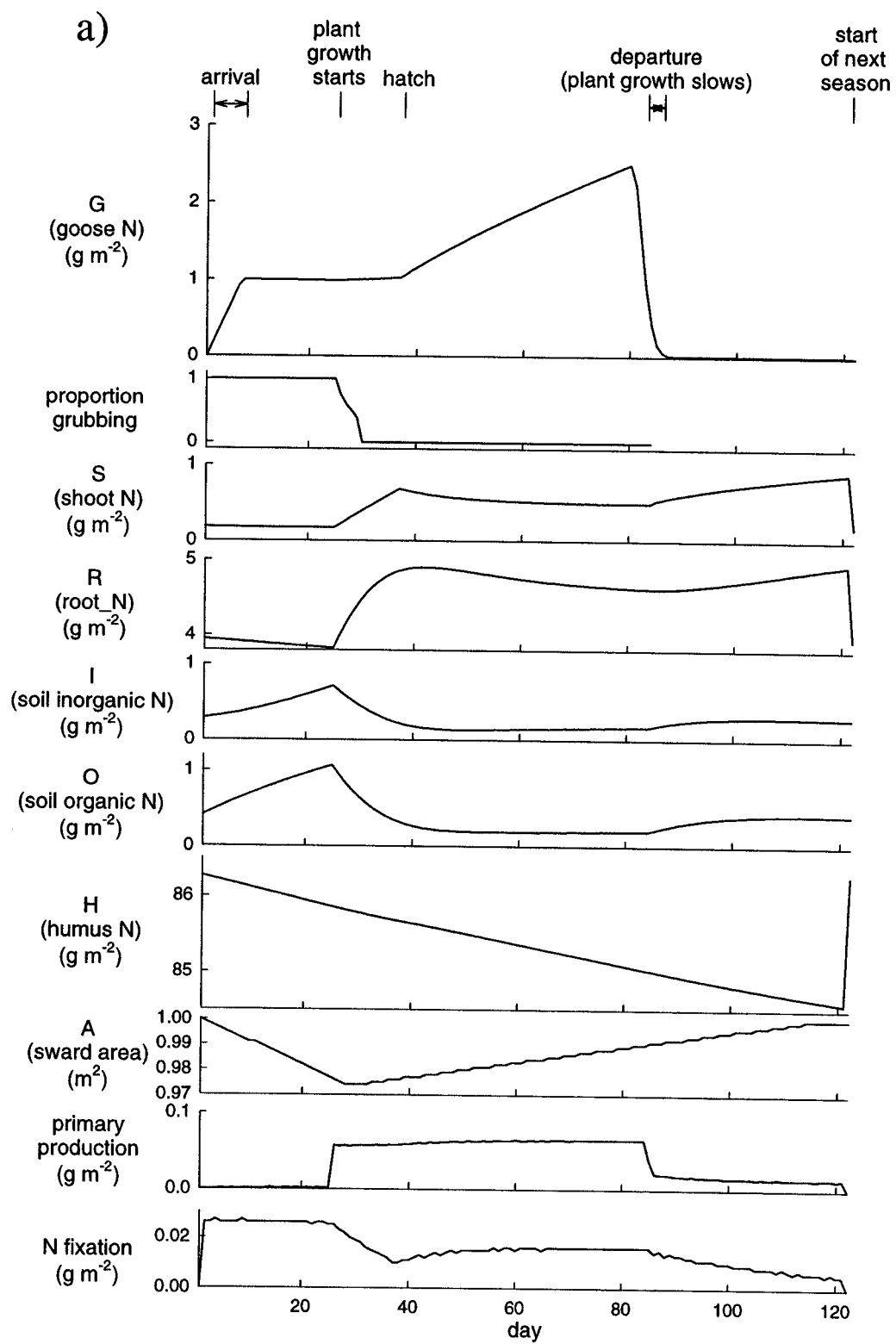

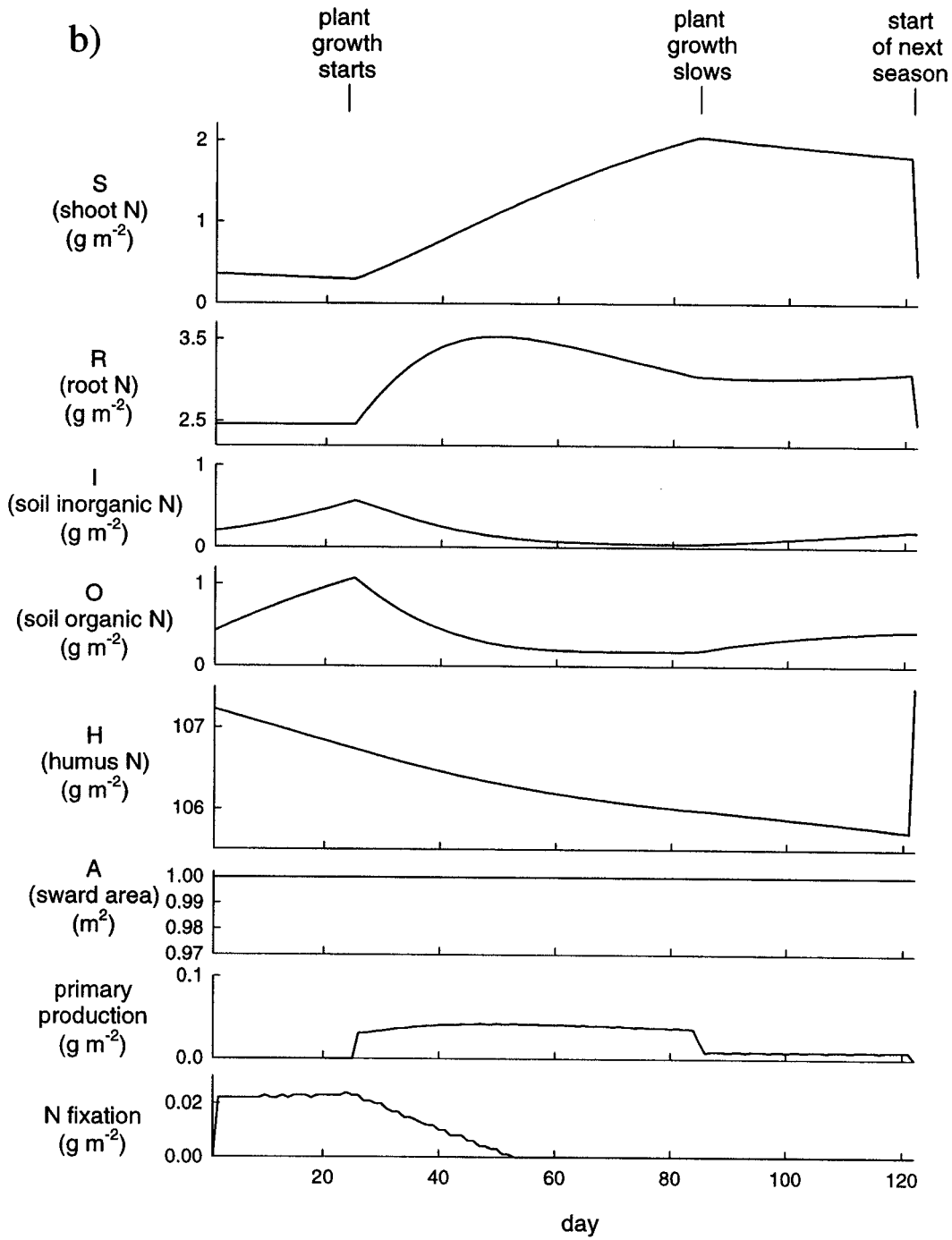

### 5.4.3 Sensitivity analyses

The net gain in goose N was found to be highly sensitive to increases in most goose parameters, several soil parameters and the initial conditions, but relatively insensitive in the long-term (> 5 years) to changes in plant parameters, which elicited only short-term, low amplitude responses (Fig. 5.5a). Specifically, (annual) net goose N gain was sensitive to changes in retention ( $r$ ), turnover ( $t_g$ ), grazing ( $g_{\max}$  and  $k_g$ ), fixation ( $f_{\max}$  and  $f_s$ ), dehumification ( $h$ ) and initial humus ( $H_0$ ). Increased goose overwinter survival ( $\sigma$ ) resulted in a strong initial increase in output of net goose N gain, but over the long term a decrease occurred as a result of a decrease in A and S.

The sensitivity of net above-ground primary production (NAPP) to changes in goose parameters differed from that of output of net goose N gain (Fig. 5.5b). In particular, increases in retention resulted in decreases in NAPP. Increases in NAPP with increased  $g_{\max}$  and  $\sigma$  were proportionally lower than those exhibited by net goose N gain. The sensitivity of NAPP to changes in soil and plant parameters and initial conditions (not shown) was similar to that of net goose N gain. A was sensitive to increases in  $\sigma$  and moderately so to changes in fixation ( $f_{\max}$ ), grazing ( $g_{\max}$  and  $k_g$ ) and grubbing ( $b$  and  $e$ ) (Fig. 5.6a). Decreases in A with increased  $\sigma$  were approximately linear up to a value of 0.48. Above that value of  $\sigma$ , the system declined sharply after 10 years or less (Fig. 5.6b).

The model could be re-parameterized to represent the steady-state budget without any uptake from O. In this situation neither net goose N gain nor NAPP were affected. However, in the runs without uptake from O,  $R$  needed to be higher ( $2.25 \text{ g m}^{-2} \text{ y}^{-1}$ ) than the highest empirical estimates ( $0.43 - 1.72 \text{ g m}^{-2} \text{ y}^{-1}$ , Wilson and Jefferies 1996) in order

**Fig. 5.5.** a) Relative Net Goose N gain for 10 % increases in individual i) goose parameters (b - grubbing;  $g_{\max}$  and  $k_g$  - grazing; r - retention;  $t_g$  - turnover;  $\sigma$  - survival), ii) soil parameters ( $f_{\max}$  and  $f_s$  - fixation; h - dehumification;  $l_s$  - leach to soil; m - mineralization; n - denitrification), iii) plant parameters (e - regeneration (-10 %);  $l_s$  - leach to shoot; p - transport;  $t_p$  - turnover;  $t_s$  - winter survival;  $u_i$  - inorganic uptake;  $u_o$  - organic uptake) and iv) initial conditions ( $A_0$  - area;  $G_0$  - goose N;  $H_0$  - humus N;  $I_0$  - Inorganic N;  $O_0$  - organic N;  $R_0$  - root N;  $S_0$  - shoot N) relative to steady-state net Goose N gain in the presence of grazing. b) Primary production for 10 % increases in individual i) goose parameters (see a,i) relative to steady-state primary production in the presence of grazing.

a)

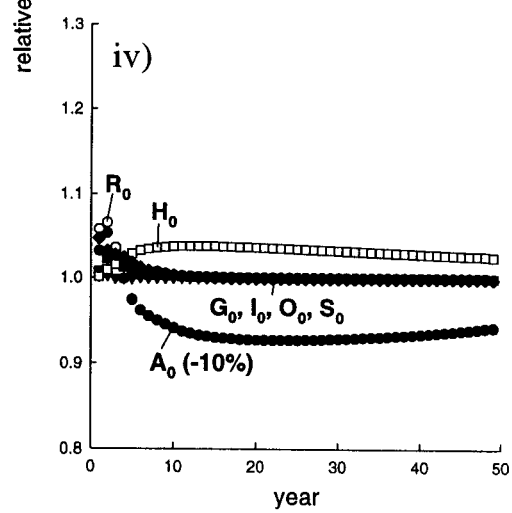
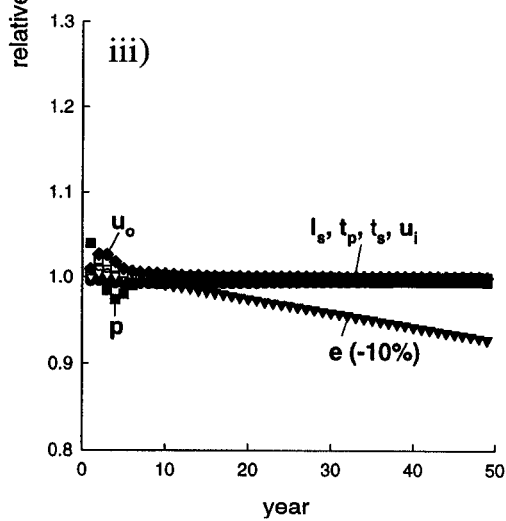
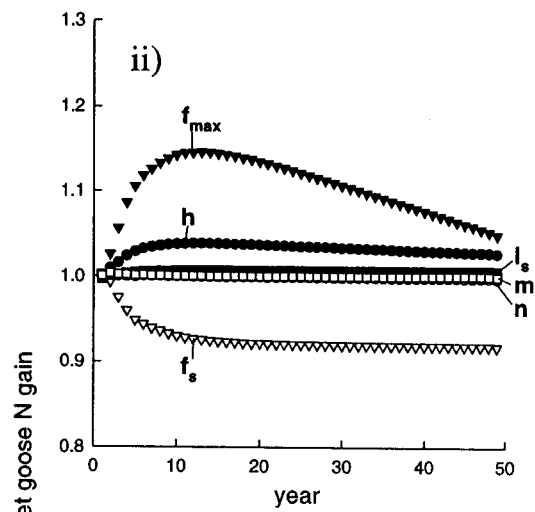
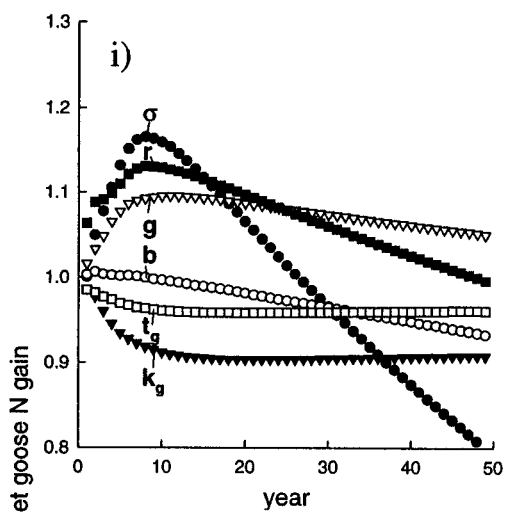

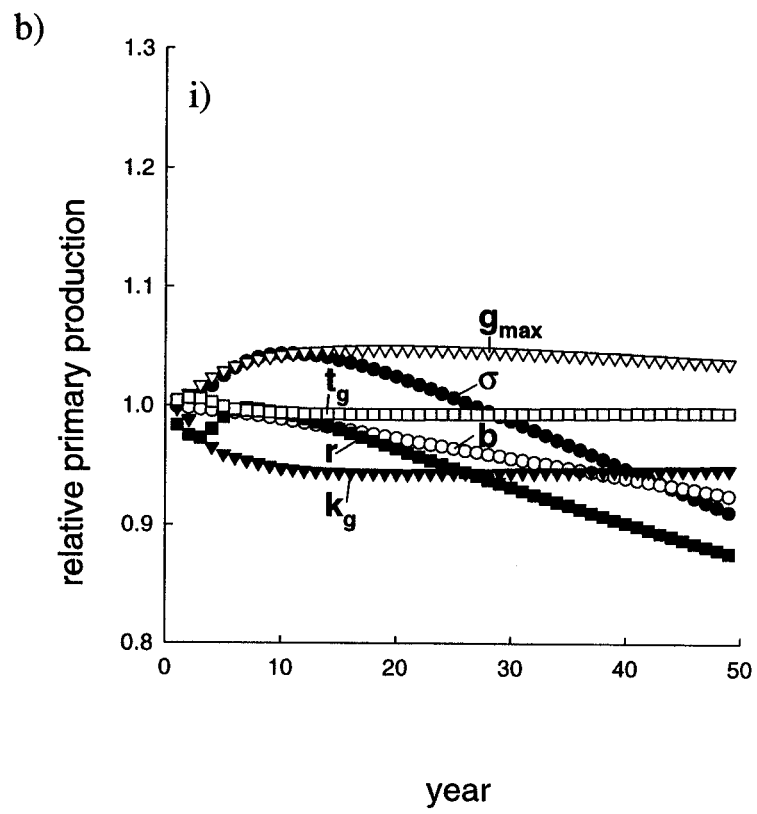

**Fig. 5.6.** a) Relative sward area remaining (end of the season values) for 10% changes in model input parameters (b - grubbing; e - regeneration (-10 %);  $k_g$  and  $g_{max}$  - grazing;  $f_{max}$  - fixation; r - retention;  $\sigma$  - survival. Only parameters eliciting a decrease in area of more than 0.5% after 50 years are shown. b) Relative sward area remaining at the end of the growing season for increments of 0.02 in goose survival. c) Relative sward area remaining after 50 years (end of season values) as a function of grubbing rate for increments of 0.02 in goose survival.

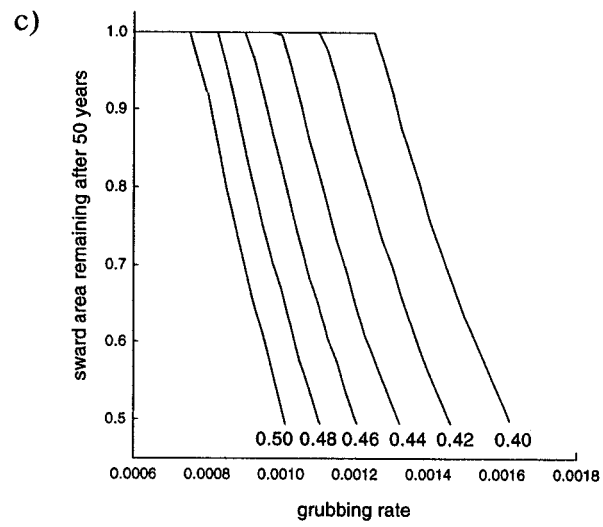
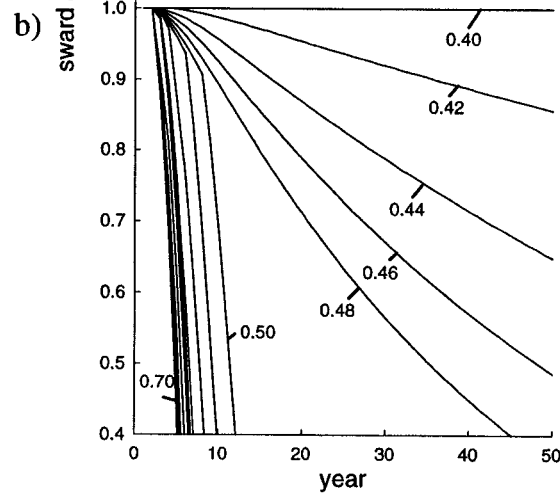
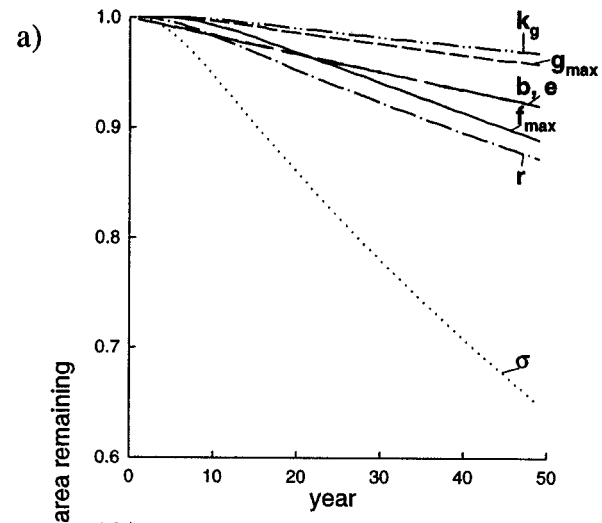

to support this level of NAPP. Mineralization in runs with organic N uptake ( $0.68 \text{ g m}^{-2} \text{ y}^{-1}$ ) was within the range of empirical estimates.

The model could also be re-parameterized to run under a steady-state in the absence of N leaching from faeces. In the absence of faecal N leaching, NAPP ( $2.9 \text{ g m}^{-2} \text{ y}^{-1}$ ) was 27% lower and the net gain in goose N ( $0.95 \text{ g m}^{-2} \text{ y}^{-1}$ ) was 41% lower than values obtained in the presence of faecal N leaching. These decreases in NAPP and net gain in goose N occurred despite a 10% increase in N fixation, which was  $2.02 \text{ g m}^{-2} \text{ y}^{-1}$  in the absence of faecal N leaching.

## 5.5 Discussion

Most models of plant growth explicitly include carbon dynamics. However, in this modelled sward of grazed graminoid vegetation, plant growth is unlikely to be carbon limited. The modelled sward, which is only about 2.5 cm high, has a leaf-area index that is about 0.2 (Bazely 1984). Consequently, PAR is little attenuated at the ground surface and plant leaves in the sward receive direct sunlight. Even in ungrazed exclosures, attenuation of PAR is minimal. Thus plant growth is unlikely to be carbon-limited. These findings and those indicating N limitation of primary production strongly support the decision to model only the dynamics of N transport and not those of N and C together.

When parameters were increased by 10% from their steady-state values, the individual effects on both N removed when the geese depart and on primary production are different (Fig. 5.5). Net goose N gain was sensitive to a wide range of variables. These included not only survival of birds, but also those processes that influenced N flow

directly or indirectly to the geese, such as increases in grubbing rate, in the retention and turnover of N by geese and in the maximum rate of nitrogen fixation. Even after 50 years, new steady state conditions were not established in the above cases. In contrast, when most plant and soil variables were increased by 10%, a new steady state was established after 15 years, although in the first 5 years changes in N removed compared to the original steady state were often abrupt (Fig. 5.4a, ii, iv). Ongoing increases or decreases in these plant and soil parameters may be expected to generate continuous non-steady state conditions that have the potential to lead to catastrophic shifts. Plant primary production is particularly sensitive to goose survival and retention of N by geese. An increase in retention leads to a rise in goose numbers and an increase in utilization of primary production by geese. Although this is not a spatially-explicit model, the model predicts that the decline in plant N caused by grubbing with increasing goose N reduces the area available for N fixation. It also reduces the size of the soil N pool, and consequently further reduces plant N. There is field evidence that the extent of grubbing in any one year is linked to adverse weather conditions farther north in early spring that force birds migrating to the High Arctic to stage longer in coastal areas of the Hudson Bay Lowlands (Skinner *et al.* 1999; Jefferies and Rockwell 2002). Where these events are restricted to one year, they may create only minor perturbations in the system, but if they are sustained over a number of years they could lead to catastrophic shifts as outlined above.

At low goose density, LPBN represents a remarkably stable system, which changes little over a range of goose densities. However one of its most interesting features is that it can be in a state where a small increase in goose survival can elicit a

progressive decrease in sward area, leading to the collapse of the system (Figs 5.6b, c).

An increase in survival from 0.4 to 0.5 shifts the system from a steady state to one where it collapses in less than 12 years. If the survival is increased to 0.7 then the collapse occurs in 7 years. These rapid effects reflect the historic changes that have occurred in the intertidal marsh in the late 1980's and the early 1990's (Jefferies and Rockwell 2002).

An additional factor, not yet modelled, is that in early spring in the late 1980s the marsh often was used by large numbers of staging birds, in addition to the breeding population of geese. This led to a temporary large increase in the population of birds before the growth of above-ground vegetation, and grubbing was intensive. This effect must be carefully modelled based on much-needed quantitative studies of grubbing behaviour. At present, we cannot determine how near the system was to collapse prior to the spring staging birds damaging the vegetation of the intertidal marsh in the late 1980's and 1990's.

Intensive grubbing resulted in much of the intertidal marsh changing to mud flats, recognised as an alternative stable state of the marsh. A state and transition model can be used to show that changes leading to this alternative stable state are effectively irreversible (Handa *et al.* 2002). In the model increased survival accounted for the increased foraging pressure of the geese, whereas field results indicate that the change came about because of the presence of large numbers of staging birds that were present at the site during several springs. In both cases the changes to the system occurred within a few years leading to the collapse of the system. The outcome is similar to those predicted by the mathematical models of catastrophic shifts in systems and alternative stable states by Van de Koppel *et al.* (1997) and Van de Koppel *et al.* (2001) for semi-arid grasslands

and tidal flats. However, in the present model, the collapse of the system is precipitated by a disruption of N fixation rather than the enhancement of nitrogen losses through erosion.

LPBN models the nitrogen flux through the plants as driven by the availability of both organic and inorganic soil N, since it has been found that the sward grass, *Puccinellia phryganodes*, can readily take up soluble organic N (Chapters 2 and 3). The model shows that if plant uptake were based solely on inorganic N then the rate of mineralization would have to be higher than observed. Hence, we believe that the model correctly accounts for the dual inputs of soluble organic and inorganic N to plants. Contributions from faeces to the soil soluble N pool may enhance plant growth provided that faecal material is not washed away by tides before it has been leached of N (Bazely and Jefferies 1985; Ruess *et al.* 1989). Although tidal export of faeces was not modelled explicitly, runs of the model in which faecal N leaching was absent show that this additional N sink reduces NAPP and makes the system less able to provide net goose N gain, despite the increase in the rate of N fixation that results from lower shoot density. The model predicts a crash at what would otherwise be a sustainable goose density.

## 5.6 Future work

Our experience with LPBN emphasizes the requirement for further experimental studies, especially of the properties of the major sources and sinks of N, which are critical in determining the stability of the modelled system. Quantitative studies of the rate of nitrogen fixation as a function of plant density (over the range from ungrazed swards to bare mud) are badly needed. We also need quantitative data of the grubbing and grazing

behaviour of geese, which at present is modelled only with the help of a number of arbitrary assumptions. Measurements are required of N turnover and N retention by geese of different ages, so that the stability of the system can be more precisely assessed. Additional data on below-ground N pools, root N turnover rate, transfer of root N to humus N and protease activity are required to improve the modelling of short-term changes in the system. In particular, studies of changes in N distribution during the winter resulting from frequent freeze-thaw cycles are needed (Hobbie and Chapin 1996) as in the Cape Churchill region 16 or more freeze-thaw cycles occur, on average, each winter (R. Bello, personal observation).

We have not included historical data on goose arrival into LPBN, although there is scope to develop such historical changes in the model. At present LPBN is not a spatially explicit model, but it could be extended to include spatial dimensions along which variation in properties and grazer choice occurs. The effects of intense grazing (Sundell *et al.* 2002), as opposed to the effects of grubbing, might be included, but quantitative data are required of the functional response of geese to the availability of forage species. Finally, there is scope for the study of effects of climate change with the model.

## Chapter 6: General Discussion

### 6.1 Overview

The availability of nitrogen in forms that can be taken up by plants limits the primary productivity of Arctic coastal salt-marshes in spite of inputs of N from sedimentation (Cargill and Jefferies 1984a). As a result of low temperatures, low precipitation and high soil salinity, inorganic forms of nitrogen are in short supply in Arctic systems in general (Atkin 1996, Lee 1999). The results presented in this thesis demonstrate that the availability of soluble organic N relative to inorganic N is high in salt-marsh soils (Chapters 2,4) and that direct uptake of organic nitrogen as free amino acids is likely an important source of N for the growth of the salt-marsh grass, *P. phryganodes* (Chapters 2,3,4). The uptake of free amino acids by this species, which accounts for a large proportion of the total plant biomass of intertidal areas, has important consequences for primary production in this system. Given that *P. phryganodes* is a major forage plant of the lesser snow goose, the dominant salt-marsh herbivore, the growth of *P. phryganodes* is closely linked with the overall productivity of the entire system (Chapter 5). In the following chapter, results presented in this thesis are synthesized, in order to address the availability of soluble nitrogen for plant uptake in Arctic salt-marsh soils, the ability of *P. phryganodes* to take up soluble nitrogen (or otherwise) and the implications of soluble organic uptake by plants for ecosystem N dynamics. Key technical limitations that currently hinder the study of amino acids uptake by plants are also discussed and directions for future research proposed.

## 6.2 Availability of soluble nitrogen for plant uptake in Arctic salt marsh soils

In contrast with most temperate agriculture soils where nitrate concentrations in the soil solution can exceed free amino acid concentrations by several orders of magnitude (Schobert and Komor 1987, Schobert *et al.* 1988, Wolt 1994), concentrations of free amino acids and soluble ammonium ions in the salt marsh at La Pérouse Bay generally were within the same order of magnitude during the growing season, whereas nitrate concentrations were low (Chapter 2). Free amino acid concentrations relative to those of inorganic nitrogen in the soil solution were highest in the intertidal zone, where the median ratio of amino acid nitrogen to ammonium nitrogen was 0.36 and amino acid concentrations exceeded those of ammonium ions in 24 % of samples. Mean nitrate concentrations were lower than free amino acid concentrations on all sampling dates. In addition to amino acids, other soluble organic N compounds, principally proteins and peptides, were present in salt-marsh soils at concentrations approximately equal to free amino acid concentrations. Some species of plants can grow on proteins or peptides as sole sources of N; however, the ability to use these organic sources appears to be dependent on the presence of mycorrhizae (Stribley and Read 1980, Abuzinadah and Read 1986, 1989, Turnbull *et al.* 1995, Chalot and Brun 1998). While plants possess transporters for small peptides and ureides (Frommer *et al.* 1994), their potential contribution to total N uptake has not been established.

Although bulk soil solution measures indicated that organic nitrogen represents a substantial proportion of the soluble N pool in Arctic salt-marsh soils, the use of bulk soil solution measures to infer plant available nitrogen has been criticized on several grounds. First, a high concentration of a given substrate in the bulk soil solution could result from

slow turnover, which could indicate low uptake rates of this substrate by both soil microorganisms and plant roots (Ingestad and Lund 1986, Ingestad 1988). This criticism does not apply to glycine in Arctic salt-marsh soils, given that glycine turned over quickly and was taken up rapidly by plant roots (Chapter 4). A second criticism of bulk soil solution measures is that they are not representative of concentrations of the different N species present at the surface of plant roots (Leadley, Reynolds and Chapin 1997, Vinolas *et al.* 2001). Substrate depletion occurs in the rhizosphere as a result of uptake by roots and root-associated microorganisms (Nye 1969, Tinker 1969). Although nitrogen concentrations at the root surface of *P. phryganodes* could not be measured directly *in situ*, results from the continuous flow experiment indicated that at typical soil concentrations of 100  $\mu\text{M}$  total nitrogen, observed transpiration rates were insufficient to replenish nitrogen at the root surface via mass flow alone assuming steady state conditions (Chapter 2). Therefore, diffusion must have contributed to nitrogen movement to the root surface in these experiments. Replenishment of root depletion zones by diffusion is more rapid for acidic amino acids and ammonium, which are well buffered in the soil solution, than for neutral and basic amino acids and nitrate (Nye 1969, Tinker 1969, Jones and Hodge 1999). However, the diffusive properties of amino acids have not been quantified for many soils (Leadley *et al.* 1997). Clearly, such data are necessary to model successfully the supply of amino acids to the root surface.

There was substantial variation in the relative concentrations of amino acids and ammonium ions among soil solution samples within salt-marsh sites (Chapter 2). Based on the results of the continuous flow experiment, free amino acids could supply tillers with adequate nitrogen for growth in soil patches where ammonium concentrations are

low. Although soil nitrogen heterogeneity is a common phenomenon at most spatial scales (Jackson and Caldwell 1993, Cain *et al.* 1999), it may be amplified in goose-grazed marshes as a result of the scattered release of goose faecal droppings, which are rapidly leached of soluble nitrogen (Ruess, Hik and Jefferies 1989). Averaged over sites, temporal variation in the overall free amino acid concentration was low over much of the growing season. In addition to amino acids leached from goose faeces, most of the amino acids at this time are likely the products of extracellular protease action on plant and microbial necromass, which is thought to be the greatest contributor to the soil free amino acid pool in Arctic soils (Kielland 1995, Hobbie and Chapin 1996, Lipson *et al.* 2001). In the late fall and early spring, the peak in soluble nitrogen concentrations that occurs is likely the result of rapid rates of microbial and root cell lysis during freeze-thaw cycles (Hobbie and Chapin 1996).

The relatively high availability of free amino acids in tundra soils may have important implications for the amino acid nutrition of geese, which ingest soil while grubbing for plant roots and rhizomes in spring. Of the 20 L-amino acids that birds incorporate into proteins, nine cannot be synthesized by bird enzymes (Klasing 1998). These amino acids, referred to as essential amino acids, are arginine, isoleucine, leucine, lysine, methionine, phenylalanine, threonine, tryptophan and valine. In addition, although histidine, glycine and proline can be synthesized, the rate is insufficient to meet a bird's metabolic demand in some situations and tyrosine and cysteine can only be synthesized when the ingestion of the essential amino acid precursors, phenylalanine and methionine, is adequate (Klasing 1998).

During reproduction and moult, birds have additional amino acid requirements beyond those of normal body maintenance. For birds that lay many large eggs, the requirement for oviduct growth and yolk synthesis may increase by more than six times maintenance levels for critical amino acids, such as methionine and leucine (Krapu and Reinecke 1992). During moult, the sulphur amino cysteine and methionine, and to a lesser extent the branched-chain amino acids valine and leucine, are required in great quantities for feather replacement (Mitchell 1959). When sulphur amino acid deficiency occurs during moult, these amino acids may be withdrawn from pectoral muscle (Hanson 1962) or converted from chondroitin sulphate and keratin sulphate from the tarsometatarsi (Herring 1973), with a resultant catabolic wasting of the donor tissues (Mitchell 1964). It has been calculated that between 2.9 and 3.6g of tissue protein must be mobilized for each gram of feather in penguins due to the mismatch in the amino acid composition of body protein and that of feather protein (Cherel *et al.* 1994). The contribution of free soil amino acids to the amino acid nutrition of geese during reproduction and moult has not been determined, but intensive grubbing occurs in late spring and also in late July and early August (time of moult) in most years. Aside from roots, the intake of sediment rich in cyanobacteria and diatoms and other microorganisms may provide “a cocktail” of essential amino acids. In recent years, increased degradation of *P. phryganodes* swards and their underlying organic substrate and a reduction in grubbing at the time of moult have coincided with the delayed development of primary feathers in goslings (Rockwell and Cooch, unpublished data). In general, the overall body mass of goslings has declined (Cooch *et al.* 1991). However, at some non-intertidal sites where the mean body mass of goslings has not decreased, this delay in feather

production may be indicative of a deficiency in sulphur-containing amino acids in the gosling diet, as the birds appear to be otherwise well-fed. Feather growth bars that denote 24 h periods of growth and feather amino acid composition may be used as indicators of nutritional status (Grubb 1989, Murphy *et al.* 1990). The presence of 'fault bars,' translucent bands in feathers caused by the defective formation of barbules, have also been attributed to dietary deficiencies; however, these do not appear to result from a deficiency in sulphur amino acids (King and Murphy 1984).

### **6.3 Uptake of soluble nitrogen by *Puccinellia phryganodes***

The ability of roots to absorb intact amino acids is ubiquitous (Fischer *et al.* 1998); however, rates of amino acid uptake relative to rates of ammonium and nitrate uptake vary substantially among species (Kielland 1994, Raab *et al.* 1999). The uptake kinetics of amino acids by roots are typically characterized by providing them with  $^{15}\text{N}$  or  $^{14}\text{C}$ -labelled substrates dissolved in hydroponic media. Although these experiments cannot reproduce the conditions experienced by plants in the field, they provide a direct comparison of amino acid and inorganic nitrogen uptake rates at set external nitrogen concentrations under controlled conditions. In *P. phryganodes*, the relative rates of uptake of amino acids, ammonium and nitrate were highly sensitive to the form of nitrogen present in the culture solution prior to excision (Chapter 3). Ammonium uptake was up-regulated in response to ammonium starvation, whereas glycine uptake was up-regulated in the presence of external glycine. When amino acids, ammonium and nitrate were provided in the growth medium, glycine uptake was equal to the combined uptake of ammonium and nitrate. Therefore, unlike nitrate uptake, which is generally low for

plants in ammonium-dominated systems (Kronzucker, Siddiqi and Glass 1997, Kronzucker, Glass and Siddiqi 1999) and which was strongly down-regulated by external glycine or ammonium ions, glycine uptake by *P. phryganodes* remained high in the presence of ammonium ions. These results cannot be extrapolated directly to predict rates of uptake by *P. phryganodes* in the field because the regulation status of field-grown roots is unknown (roots cannot be removed from the mineral substrate without incurring substantial damage). However, they do indicate that rates of glycine uptake may be comparable to rates of ammonium uptake if both substrates are present at similar concentrations at the root surface.

The incorporation of  $^{13}\text{C}$  into the roots of *P. phryganodes* following the injection of  $^{13}\text{C}^{15}\text{N}$ -labelled glycine into soils indicated that some glycine was absorbed intact by roots *in situ*; however, the low ratio of  $^{13}\text{C}$  incorporation relative to  $^{15}\text{N}$  incorporation indicated that much of the  $^{15}\text{N}$  may not have been absorbed as the intact amino acid (Chapter 4). When excised roots of *P. phryganodes* were immersed in hydroponic medium over a short-time course of 20 min,  $^{13}\text{C}$  incorporation was only half that of  $^{15}\text{N}$  incorporation (Chapter 2). The latter result was unexpected, given that microorganisms were not present in the hydroponic medium (with the possible exception of root surface contamination, which appeared to be minimal). Furthermore, the time course of the experiment was too short for large respiratory  $^{13}\text{C}$  losses to have occurred (see below). In many algae and fungi, extracellular deamination of amino acids can occur at the cell surface, followed by uptake of ammonium ions (Paul and Cooksey 1979, 1981, DeBusk *et al.* 1981, Munoz-Blanco, Hidalgo-Martínez and Cárdenas 1990). Although extracellular deaminases have not been localized on the surface of root cell membranes,

hypothetically, their presence could explain the low  $^{13}\text{C}$  incorporation of  $^{13}\text{C}^{15}\text{N}$ -amino acids from hydroponic media and could also explain part of the discrepancy between  $^{13}\text{C}$  and  $^{15}\text{N}$  incorporation in the field. Extracellular deamination of amino acids by soil microorganisms also could potentially lead to an overestimation of intact uptake by roots if both deamination products ( $^{13}\text{C}$  and  $^{15}\text{N}$ ) are absorbed. However, the use of gas chromatography-mass spectrometry confirmed that  $^{13}\text{C}^{15}\text{N}$ -amino acids remained intact following uptake by the roots of wheat (Näsholm, Huss-Danell and Högberg 2001). Alternatively, the extent of intact amino acid uptake could likely be resolved by examining the synchrony of  $^{13}\text{C}$  and  $^{15}\text{N}$  incorporation into roots over a short-time course.

There are numerous alternative explanations for why the ratio of  $^{13}\text{C}$  to  $^{15}\text{N}$  incorporation may underestimate the proportion of amino acids absorbed intact *in situ*. Foremost,  $^{13}\text{C}$  absorbed as intact amino acid may be lost as a result of respiration (Schimel and Chapin 1996). In the present study, respiratory losses were minimized by employing a relatively short incubation time of 24 h and by using amino acids labelled in the 2-C position rather than the 1-C position, which is prone to rapid respiratory decarboxylation (Fokin *et al.* 1993). Nevertheless, the carbon in the 2-C position can still be respired following deamination and breakdown of the C-skeleton in the Krebs cycle (Näsholm and Persson 2001) and as a result some  $^{13}\text{C}$  may have been lost to respiration within 24 h. Respiratory  $^{13}\text{CO}_2$  losses remain an inherent problem associated with the use of dual-labelled amino acids to infer intact amino acid uptake.

A further explanation for the apparently low uptake of  $^{13}\text{C}$  uptake by roots *in situ* is the large error associated with the high dilution of  $^{13}\text{C}$  in plant material. The dilution of  $^{13}\text{C}$  in plants is 60 -150 times that of  $^{15}\text{N}$  as a result of high carbon to nitrogen ratios in

plant tissue and the relatively high natural abundance of  $^{13}\text{C}$  relative to  $^{15}\text{N}$  (Näsholm and Persson 2001). Therefore, when realistically low levels of substrate are added to the soil,  $^{13}\text{C}$  enrichment in plants may be low relative to natural variation and analytical error. In short-term labelling experiments, tracers absorbed by roots are predominately present in soluble compounds. Recently, a technique has been developed whereby the proportion of tracer in samples is amplified by removing the insoluble fraction of plant material prior to isotopic analyses (Näsholm, Huss-Danell and Högberg 2001). The concentration of  $^{13}\text{C}$  obtained is 10 times higher than that obtained using dried plant materials and as a result greater  $^{13}\text{C}$  uptake is discernable.

The uptake of free amino acids by plants *in situ* largely reflects the outcome of competition between roots and soil microorganisms. Soil microorganisms are ubiquitous in the soil, possess high surface area to volume ratios and often exhibit high relative growth rates. They also may be located closer than roots to the location of extracellular protease activity. As a result, typically they have been expected to outcompete roots for soil amino acids (Kaye and Hart 1997). Tillers of *P. phryganodes* captured 17% of amino acid  $^{15}\text{N}$  added to soil, as compared with 30% captured by soil microbial biomass (Chapter 4). In comparison, *P. phryganodes* captured 29 and 19% of  $^{15}\text{N}$  from ammonium and nitrate ions, respectively, and the soil microbial biomass captured 34 and 29%. These results indicate that roots of *P. phryganodes* competed well for both amino acids and inorganic nitrogen. In short-term uptake experiments, root uptake may be underestimated relative to microbial uptake because  $^{15}\text{N}$  present in mycorrhizae is included in the soil microbial fraction when roots are removed and hyphae tear loose and remain in the soil (Näsholm and Persson 2001). Further efforts must be made to

distinguish between uptake by plant symbionts and competing soil microorganisms.

In long-term experiments, plant  $^{15}\text{N}$  uptake relative to microbial uptake is higher than that in short-term experiments as a result of the rapid turnover time of microbial biomass relative to root biomass (i.e.  $^{15}\text{N}$  may cycle through the microbial biomass numerous times and eventually be absorbed by roots). Therefore, the competitive abilities of plants for nitrogen in the long-term may ultimately be determined by their abilities to capture nitrogen liberated by microbial turnover. However, it is not possible in long-term experiments to distinguish intact amino acid uptake from inorganic N uptake.

Variation in the relative competitive abilities of plants and microorganisms for ammonium and nitrate ions may reduce plant-microbial competition for N (Norton and Firestone 1996). Likewise, plant-microbial competition may be further reduced as a result of variation in competitive abilities for organic and inorganic nitrogen (Lipson and Monson 1998). In the present study, inorganic versus organic uptake differed between plants and soil microorganisms (Chapter 4). The outcome of competition between plants and microorganisms can also vary substantially among different amino acids (Lipson *et al.* 1999) and temporal partitioning in amino acid use between plants and microorganisms may further reduce plant-microbial competition (Lipson and Monson 1998).

While both amino acids and ammonium appear to contribute substantially to N uptake in *P. phryganodes*, the contribution of nitrate to N uptake is less clear. Based on the low uptake rates of nitrate from hydroponic solution (Chapter 3) and the relatively low concentration of nitrate in the bulk soil solution (Chapter 2), it was expected that rate of nitrate uptake by this species in the soil would be low. Nitrate reductase activity in roots of *P. phryganodes* is also relatively low, even when soils are amended with 50 mM

potassium nitrate (R. L. Jefferies, *pers. comm.*). However, root  $^{15}\text{N}$  enrichment was high following the injection of  $\text{K}^{15}\text{NO}_3$  to the soil (Chapter 4) and in a sand culture nutrient-addition experiment, tillers grew equally well on  $\text{KNO}_3$  and  $\text{NH}_4\text{Cl}$  at low  $\text{NaCl}$  concentrations (unpublished data). These results imply that either nitrate was taken up directly by roots in the field, or it was reduced to ammonium in the soil prior to uptake or absorbed by mycorrhizae (mycorrhizae did not appear to be associated with roots in hydroponic solution, where rates of nitrate uptake were low).

Sodium chloride typically interferes more severely with nitrate uptake than with ammonium uptake (Cram 1973, Deane-Drummond and Glass 1982, Xu *et al.* 2000); however, its effect on amino acid uptake by plant roots has not been explored previously. In *P. phryganodes*, rates of amino acid uptake relative to ammonium uptake were greatest at high salinities. Therefore, *P. phryganodes* can likely capitalize on the relatively high ratio of free amino acids to ammonium present in the soil from mid-to-late growing season, with the onset of high salinity. Rates of glycine uptake increased slightly with decreasing  $\text{NaCl}$  concentration in the external solution, likely due to the alleviation of adverse osmotic effects. However, the rate of glycine uptake peaked at low salinity (5-10 mM), and declined at lower external  $\text{NaCl}$  concentrations (unpublished data - variation in uptake rates between replicates was high at low external  $\text{NaCl}$  concentrations). While any explanation for this apparent effect remains speculative, this decline in amino acid uptake at very low  $\text{NaCl}$  concentrations may reflect the presence of sodium co-transport of amino acids, a phenomenon that is common in animals and bacteria yet remains to be demonstrated in plants (Fischer *et al.* 1998).

Ammonium uptake is less cold-temperature sensitive than nitrate uptake in many Arctic species (Chapin *et al.* 1986, Atkin and Cummins 1994). Reductions in nitrogen uptake at low temperatures may result from a direct effect on nitrogen transport sites or the fluidity of the cell membrane (Clarkson and Warner 1979), or they may be mediated through indirect effects on nitrogen demand caused by a low relative growth rate (Atkin and Cummings 1994). Nevertheless, it remains unclear why these suppressive effects are stronger for nitrate uptake than for ammonium uptake. In *P. phryganodes*, the uptake of ammonium was less sensitive to low temperatures than the uptake of glycine (Chapter 3). This result, coupled with the relative insensitivity of glycine uptake to NaCl, reinforces the hypothesis that amino acid uptake relative to inorganic nitrogen uptake is likely highest during the mid-to-late growing season. Although the effects of temperature were not tested formally *in situ*, the ratio of  $^{13}\text{C}$  relative to  $^{15}\text{N}$  in plant tissue following injection of dual-labelled  $^{13}\text{C}^{15}\text{N}$ -glycine into the soil was significantly higher in 2001 (a warm year) than in 2000 (a cold year) (Chapter 4). Early in the season, high rates of ammonium uptake relative to glycine uptake at low temperatures coincide with a pulse in high ammonium concentrations in the soil solution (Chapter 2). However, given the low quantity of live microbial and root biomass present at this time, much of this nitrogen may be lost from the system in spring runoff (Hobbie and Chapin 1996, Lipson and Monson 1998).

The relative uptake of free amino acids and ammonium ions by plant roots can vary depending on the pH of the external solution (Soldal and Nissen 1978, Falkengren-Grerup, Månsson and Olsson 2000, Thorton 2001). In *P. phryganodes*, uptake of glycine increased with decreasing pH, whereas the uptake of ammonium ions decreased (Chapter

3). Plants that absorb nitrogen primarily as ammonium rather than nitrate tend to promote acidification of the rhizosphere (Nye 1981). In *P. phryganodes*, this would favour amino acid uptake over ammonium uptake; however, root zone acidification in this species has not been explored.

Overall, the effects of pH, salinity and temperature on nitrogen uptake in the field remain speculative. Nevertheless, the sensitivity of N uptake by *P. phryganodes* roots to changes in these factors in hydroponic media suggests that the relative rates of amino acid and ammonium uptake may vary substantially with variation in climatic and edaphic conditions. Furthermore, this sensitivity emphasizes the importance of carefully selecting and controlling the conditions of the hydroponic media in uptake experiments and cautions against comparing uptake rates between studies.

In the long term, the balance of inorganic and soluble organic N in soils could shift substantially as a result of climate warming (Lipson and Näsholm 2001). It is currently predicted based on general circulation models that the mean global temperature will increase by 1.4-5.8 °C in the next 50-100 years, with greater warming occurring at higher latitudes (IPCC 2001). Although responses to climate warming vary widely among systems, warming generally leads to increases in soil respiration, net N mineralization rates and plant productivity (Rustad *et al.* 2001). Increased mineralization rates would likely favour the availability of inorganic N over soluble organic N in soil. The relative competitive abilities of plants for inorganic versus organic N vary widely (Kielland 1994, Raab *et al.* 1999, Falkengren-Grerup *et al.* 2000, Persson and Näsholm 2001), and temporal and spatial variation in soil inorganic and soluble organic N concentrations are also common (Kielland 1995, Lipson *et al.* 1999, Chapter 2). In Arctic plant

communities, the spatial or temporal partitioning of organic and inorganic nitrogen sources among species can reduce competition and promote species diversity (McKane *et al.* 2002). This partitioning of N between species would likely be disrupted by a shift in the balance of inorganic and soluble organic N in Arctic soils as a result of climate warming.

Despite increases in precipitation, Arctic soils are also expected to become drier because soil moisture is determined more by temperature (i.e. evapotranspiration) than by rainfall (Rowntree 1997). Presently, the combination of waterlogged soils and low temperatures results in slow organic matter decomposition and high soil acidity in many northern systems (Atkin 1996). Both soil acidity and low temperatures inhibit nitrification more severely than the ammonification of organic matter and as a result many northern soils are dominated by ammonium (and free amino acids), with the exception calcareous soils, which are often dominated by nitrate (Nadelhoffer *et al.* 1991). Warmer temperatures and drier soils are expected to decrease soil acidity and increase the availability of nitrate as a proportion of total available N, which would potentially shift many Arctic systems away from ammonium dominance (Nadelhoffer *et al.* 1992). However, nitrification rates still may remain low in Arctic salt-marshes as a result of increased rates of evapotranspiration and an increase in soil salinity.

Increases in the rate of nitrogen cycling within ecosystems may occur directly as a result of the effect of warmer temperatures on microbial activity or indirectly through warming-induced shifts in plant species composition (Hobbie 1996, Shaver *et al.* 2001). With climate warming, the combination of increased rates of N turnover and a shift to nitrate-dominated soils would favour fast-growing plant species from fertile sites over

inherently slow-growing species which have fixed, conservative demands for N and a limited ability to induce nitrate reductase activity under field conditions (Atkin 1996). In particular, the results of artificial warming experiments indicate that deciduous shrubs and particularly graminoids tend to be favoured over cryptogams (Cornelissen *et al.* 2001, Graglia *et al.* 2001). Changes in cryptogam abundance will have important consequences for future carbon and nitrogen cycling, since cryptogam litter, is extremely recalcitrant and has a low potential to mobilize N relative to graminoid litter (Hobbie 1996). In addition, many northern plants that occur naturally on soil enriched in ammonium, such as ericaceous species and many conifers, show a clear preference for ammonium over nitrate (Pearson and Stewart 1993). These species do not appear to suffer from ammonium toxicity, yet they exhibit low rates of nitrate uptake and accumulation as a result of high rates of nitrate efflux (Kronzucker, Siddiqi and Glass 1997, Min *et al.* 1999). A shift in northern systems away from ammonium dominance would likely result in the replacement of these species by those better capable of absorbing and utilizing nitrate.

#### **6.4 Implications of soluble organic uptake for ecosystem N dynamics**

Although organic nitrogen uptake by plants may play a pivotal role in terrestrial nitrogen cycling in some ecosystems (Chapin 1995), studies on plant organic nitrogen have rarely been extended quantitatively to address the consequences of organic nitrogen uptake by plants at the ecosystem level. Given that *P. phryganodes* is a primary forage species of the lesser snow goose, the dominant salt-marsh herbivore at La Pérouse Bay, processes that affect its growth are expected to impact the productivity of the entire salt-

marsh system. This hypothesis was tested with the use of a model to describe the movement of nitrogen within the salt-marsh system (Chapter 5).

In the model, two response variables were used to describe the growth of plants and geese respectively: a) net annual primary production and b) net (annual) goose nitrogen gain. Both variables were highly sensitive to changes in nitrogen fixation parameters, which regulated the input of nitrogen into the system, and changes in goose grazing, grubbing, nitrogen retention and survival parameters, all of which regulated the loss of nitrogen from the system. In contrast, net annual primary production and net goose nitrogen gain were relatively insensitive to changes in soil turnover and plant uptake, both of which regulated the internal transport of nitrogen within the system. This relative insensitivity of the model to internal transport parameters occurred as a result of changes in nitrogen pool sizes that quickly re-established initial steady-state flows of nitrogen to plants and geese. For example, if the root organic nitrogen uptake parameter was decreased, then the pool size of organic nitrogen increased, causing the mineralization rate to rise. This increased rate of mineralization then increased both the inorganic nitrogen pool size and the rate of root inorganic nitrogen uptake, which returned plant production and net goose nitrogen gain to their initial steady-state levels.

Although the model was relatively insensitive to changes in root uptake parameters, it would be erroneous to infer that root amino acid uptake has a negligible effect on the productivity of the system. Specifically, if root organic nitrogen uptake was excluded altogether, the rate of nitrogen mineralization needed to maintain plant production and net goose nitrogen gain at realistic levels exceeded the range of mineralization rates that have been measured in the field. Therefore, although the model

was relatively insensitive to changes in the parameterization of organic nitrogen uptake, the inclusion of root organic nitrogen uptake in the model was essential to obtain values of plant primary production and net goose nitrogen gain that were consistent with the empirically-derived static nitrogen budget (Wilson 1993).

Despite the ability of the model to produce realistic intra-annual variation in nitrogen pools and steady-state annual fluxes between nitrogen pools, stronger empirical data are required for describing fixation rates as a function of plant density. Root nitrogen pool sizes and root turnover and the grazing and grubbing behaviour of geese also need to be more precisely quantified in order to improve the predictive value of the model. In addition to obtaining better descriptions of functional relationships already present in the model, the inclusion of an explicit microbial nitrogen pool would be useful to explore the consequences of competition between soil microorganisms and plant roots for organic nitrogen. In the current model, microbial biomass is only modelled indirectly through its effect on soil nitrogen turnover processes. Regardless of the rate of N turnover, both soluble organic and inorganic nitrogen are ultimately taken up by plant roots. This may be approximate to a certain extent to what happens in the field, where the soil microbial biomass turns over quickly relative to root biomass. However, organic nitrogen capture by plants can have important consequences for nitrogen retention within ecosystems, particularly in those systems where inorganic nitrogen deposition is low and dissolved organic nitrogen comprises a large portion of nitrogen runoff losses (Perakis and Hedin 2002, Van Breeman 2002). As evident from the empirical data on soil soluble N concentrations (Bazely 1984, Chapter 2), a large pulse in soluble nitrogen, derived in part from the lysis of microbial cells, appears to be lost from the system each spring.

Such losses are not currently incorporated into the model. Root organic nitrogen uptake may allow plants to co-opt a larger fraction of the total soluble nitrogen pool, such that less nitrogen is lost from the system as a result of microbial lysis during freeze-thaw events. Further efforts must be made to identify periods of rapid microbial turnover and to assess the abilities of plants to capture nitrogen liberated from microorganisms before it is lost from the system. N runoff losses from ecosystems must also be considered with respect to global warming and the latter's probable influence on the timing and frequency of freeze-thaw events.

## 6.5 Conclusions

Overall, the results presented in this thesis demonstrate that the availability of soluble organic N relative to inorganic N is high in salt-marsh soils and that the direct uptake of organic nitrogen as free amino acids is likely an important contribution to the growth of the salt-marsh grass *P. phryganodes*. This is the first study to demonstrate free amino acid uptake by an Arctic halophyte and one of the first to model the effects of plant amino acid uptake on N cycling processes at the ecosystem level. Given that the direct uptake of organic N contributes substantially to plant growth in many Arctic, alpine and boreal systems, the differential use of organic and inorganic N by different species may structure plant community composition. Furthermore, perturbations such as climate change or soil degradation may affect the balance of soluble organic and inorganic N in soils, which not only affects the growth of primary producers but also may influence the nutrition and growth of organisms at higher trophic levels. Clearly, the widespread use of organic N by plants raises many questions that are central to the field

of ecology and the uptake of organic N must be routinely included in studies of N dynamics in terrestrial ecosystems (Lipson and Näsholm 2001).

## Appendix 1. Preparation of Hoagland's solution for hydroponic media

### Reagents:

1. 0.5 M  $K_2SO_4$
2. 1 M  $CaCl_2 \cdot 2H_2O$
3. 1 M  $KH_2PO_4$
4. 1 M  $MgSO_4 \cdot 8H_2O$
5. 0.02 M Fe-EDTA
6. 1 M  $NH_4NO_3$

### Procedure:

1. To obtain 1 L of 10X stock solution, fill 1 L volumetric flask with 600-700 mL of water and add the following quantities of the above stock solutions:

- 40 mL  $K_2SO_4$
- 40 mL  $CaCl_2 \cdot 2H_2O$
- 20 mL  $KH_2PO_4$
- 10 mL  $MgSO_4 \cdot 8H_2O$
- 10 mL Fe-EDTA
- 80 mL  $NH_4NO_3$

2. Mix and top up flask to 1 L.
3. Dilute to 0.1X for hydroponic media by diluting 1:100 with clean, fast-flowing river water.
4. 10X stock can be stored for several weeks by transferring it to clean container and storing in a cool, dark place.

(modified from Hoagland and Arnon 1950)

## Appendix 2. Uptake of $^{15}\text{N}$ -substrates by excised roots

### Reagents:

1. 1 M  $\text{CaCl}_2 \cdot 2\text{H}_2\text{O}$
2. 1 M KCl
3. 10 mM  $^{15}\text{N}$ -substrates

### Procedure:

1. Acid wash all glassware, plastic beakers and trays that will be used in experiment.
2. Dilute 1 M  $\text{CaCl}_2$  stock 1:2000 with deionized water to obtain an appropriate quantity (3-4 L) of 0.5 mM  $\text{CaCl}_2$ . This will be used as a base solution throughout the experiment. For salt-marsh plants,  $2.922 \text{ g L}^{-1}$  NaCl may be added to obtain a final concentration of 50 mM NaCl.
3. Excise roots from plants grown in hydroponic media. Place in small quantity of base solution.
4. For each replicate, select new, white roots and weigh into a bundle of 180 mg f.w. Encase loosely in cheesecloth 'teabag' closed with a plastic bread clip attached to a string. Allow roots to equilibrate for 20 min in aerated 0.5 mM  $\text{CaCl}_2$  holding solution at desired temperature. Save 300-400 mg root material as a control.
5. Place teabags at timed intervals into plastic beakers containing 200 mL 0.5 mM  $\text{CaCl}_2$  and the desired concentration of  $^{15}\text{N}$ -substrate (0.2 mL of 10 mM  $^{15}\text{N}$  stock added to 200 mL should provide  $10 \mu\text{M } ^{15}\text{N}$ ). Solution should be aerated vigorously by immersing a pasteur pipette attached to an airline.
6. After 20 min of incubation, remove each teabag, rinse briefly in 0.5 mM  $\text{CaCl}_2$  then immerse in a solution of 0.5 mM  $\text{CaCl}_2$  and 5 mM KCl for 5 min.
7. Spin teabag to remove excess solution, blot on filter paper and remove roots.
8. Dry roots at  $60^\circ\text{C}$  for 3-4 days.
9. Grind roots into fine powder and weigh approximately 3 mg at a precision of  $1 \mu\text{g}$  into 3.5 mm X 5 mm tin capsules. Analyse for  $^{15}\text{N}/^{14}\text{N}$  using a mass spectrometer.

(modified from Epstein, Schmid and Rains 1963)

### **Appendix 3. Total N determination using alkaline persulfate oxidation**

#### **Reagents:**

1. Prepare oxidizing reagent by dissolving 25 g low-N  $K_2S_2O_8$  and 15 g  $H_3BO_3$  in 50 mL of 3.75 M NaOH and making up volume to 500 mL with deionized water.

#### **Procedure:**

1. Pipette 2 mL of soil extract and 2 mL of oxidizing reagent into a glass tube and seal immediately with a screw cap containing a PTFE liner.
2. Weigh tubes and place in autoclave for 30 min at 120 °C. Reweigh tubes to determine water loss, if any.
3. Analyze nitrate concentration of solution.

(modified from Cabrera and Beare 1993)

## Appendix 4. $^{15}\text{N}$ turnover and uptake by plants *in situ*

### Reagents:

1. 1 mM  $^{15}\text{N}$ -substrates
2. 2 M KCl
3. 0.5 M  $\text{CaCl}_2$
4. 2.5 M  $\text{KHSO}_4$
5. MgO
6. 0.14 M  $\text{NH}_4\text{Cl}$  / 2 M KCl
7. Devarda's alloy
8. 10 M NaOH

### Procedure:

1. Collect pairs of soil cores using 7.6 cm diameter X 6 cm deep galvanized steel rings, then wrap in plastic film and transport back to field laboratory.
2. Inject cores in a 7-point hexagonal pattern with a total of 7 ml of 1 mM  $^{15}\text{N}$  solution using 15 cm double-sideport spinal syringes. Draw up syringe while injecting to evenly distribute the solution at all depths of the core.
3. a) Immediately, mix soil from one core and extract a 15 g subsample in 75 ml of chilled 2 M KCl on ice for 1 h, filter through Whatman GF/A filter paper, then freeze. Collect a second subsample to determine the fw/dw ratio. Incubate the second core at soil temperature for 24 hours prior to mixing and extraction.  
  
b) Collect subsamples of plant root and shoot material and rinse 3 times in 0.5 M  $\text{CaCl}_2$ . Dry plant materials at 60 °C for 3-4 days, grind into fine powder and weigh approximately 3 mg at a precision of 1  $\mu\text{g}$  into 3.5 mm X 5 mm tin capsules. Analyse for  $^{15}\text{N}/^{14}\text{N}$  in mass spectrometer.
4. To recover  $\text{NH}_4^+$ , construct traps by pipetting 5  $\mu\text{M}$  of 2.5 M  $\text{KHSO}_4$  onto 7 mm disks of N-leached Whatman No. 1 filter paper and by encasing the disks in folded strips of PTFE thread sealing tape.
5. For each sample, add one trap and 0.2 g MgO to 8 ml of KCl extract and 20 ml of a 0.14 M  $\text{NH}_4\text{Cl}$  / 2 M KCl carrier solution and place in sealed 75 ml plastic specimen containers.

6. Diffuse for 6 days and mix solutions daily.
7. Dry traps in a dessicator over  $\text{H}_2\text{SO}_4$  and analyse for  $^{15}\text{N}/^{14}\text{N}$  ratio and N content using a mass spectrometer.
8. To recover  $\text{NO}_3^-$ , first add 0.2 g MgO to open containers and allow  $\text{NH}_4$  to volatilize for 6 days.
9. Add 0.4 g Devarda's alloy and an ammonium trap to each container and follow steps 6 and 7.
10. To recover  $^{15}\text{N}$ -amino acids, add 0.4 g of Devarda's alloy to alkaline persulfate oxidations of KCl extracts (Appendix 3) to determine total  $^{15}\text{N}$  (substitute 10 M NaOH for MgO as a base). Subtract  $^{15}\text{NH}_4$  and  $^{15}\text{NO}_3$  from this total to give an estimate of  $^{15}\text{N}$  amino acid.
11. Include blanks, N standards and diffused and non-diffused  $^{15}\text{N}$  standards for all diffusion analyses.

(modified from Hart *et al.* 1994 and Stark & Hart 1996)

## Appendix 5. Microbial C and N estimation using chloroform fumigation extraction

### Reagents:

1. 0.5 M  $K_2SO_4$
2. ethanol-free chloroform
3. 0.07 M  $K_2Cr_2O_7$
4. 98%  $H_2SO_4$
5. 88%  $H_3PO_4$
6. 0.01 N  $Fe(NH_4)_2(SO_4)_2 \cdot 6H_2O$  in 0.4 M  $H_2SO_4$
7. 4.7 mM N-phenylanthranilic acid
8. 0.01 M of  $Na_2CO_3$

### Procedure:

1. For each replicate, collect two 70 g subsamples and clear of live plant materials.
2. Immediately extract the first subsample in 140 ml of 0.5 M  $K_2SO_4$  for 1 h, filter through Whatman GF/A filter paper, then freeze.
3. Mix the second subsample in a sealed 250 ml glass Schott bottle with 2 ml of ethanol-free chloroform. Following incubation in the dark at room temperature for 24 h, open the bottle and allow to evaporate for 30 min, then extract as described above.
4. Measure total extractable N as nitrate following alkaline persulfate oxidation (Appendix 3).  $^{15}N$  substrates may be recovered using the  $NH_4^+$  diffusion method described in Appendix 4.
5. a) To measure extractable C, pipette 1 mL of soil extracts into a boiling tube and treated with 1 ml of 0.07 M  $K_2Cr_2O_7$ , 2 ml of 98%  $H_2SO_4$ , and 1 ml of 88%  $H_3PO_4$ . Calibrate values using a glucose standard.  
b) Mix and digest at 150 °C for 30 min.  
c) After cooling, titrate samples with 0.01 N  $Fe(NH_4)_2(SO_4)_2 \cdot 6H_2O$  in 0.4 M  $H_2SO_4$  using 120  $\mu$ l of 4.7 mM N-phenylanthranilic acid and 0.01 M of  $Na_2CO_3$  as an indicator.

(modified from Witt *et al.* 2000)

## References

- Abraham, K.F. and Jefferies, R.L. (1997) High goose populations, causes, impacts and implications. *Arctic Ecosystems in Peril: Report of the Arctic Goose Habitat Working Group*. A Special Publication of the Arctic Goose Joint Venture of the North American Waterfowl Management Plan (ed. B.D.J.Batt), pp. 7-72, Paulsen, Memphis, Tennessee.
- Abuarghub, S.M. and Read, D.J. (1988) The biology of mycorrhiza in the Ericaceae XII. Quantitative analysis of individual free amino acids in relation to time and depth in the soil profile. *New Phytologist* **108**: 433-442.
- Abuzinadah, R.A. and Read, D.J. (1986) The role of proteins in the nitrogen nutrition of ectomycorrhizal plants I. Utilization of peptides and proteins by ectomycorrhizal fungi. *New Phytologist* **103**: 481-493.
- Abuzinadah, R.A. and Read, D.J. (1989) The role of proteins in the nitrogen nutrition of ectomycorrhizal plants IV. The utilization of peptides by birch (*Betula pedula* L.) infected with different mycorrhizal fungi. *New Phytologist* **112**: 55-60.
- Ågren, G.I. (1985) Limits to plant production. *Journal of Theoretical Ecology* **113**: 89-92.

- Agriculture Canada Expert Committee on Soil Survey (1987) The Canadian System of Soil Classification. 2nd. ed. Agriculture Canada Publication 1646.
- Andrews, J.T. (1973) The Wisconsin Laurentide ice-sheet: dispersal centers, problems of rates of retreat, and climatic interpretations. *Arctic and Alpine Research* **2**: 115-134.
- Aslam, M., Travis, R.L., Rains, D.W. and Huffaker, R.C. (1996) Effect of root perturbation and excision on nitrate influx and efflux in barley (*Hordeum vulgare*) seedlings. *Physiologia Plantarum* **97**: 425-432.
- Atkin, O.K. (1996) Reassessing the nitrogen relations of Arctic plants: A mini-review. *Plant, Cell & Environment* **19**: 695-704.
- Atkin, O.K. and Cummins, W.R. (1994) The effect of root temperature on the induction of nitrate reductase activities and nitrogen uptake rates in arctic plant species. *Plant and Soil* **15**: 187-197.
- Babb, T.A and Whitfield, D.W.A. (1977) Ecosystem Models. Truelove Lowland, Devon Island, Canada. *A High Arctic Ecosystem*. (ed. L.C.Bliss), pp. 587-620. The University of Alberta Press, Edmonton.

- Bajwa, R. and Read, D.J. (1985) The biology of mycorrhizae in the Ericaceae. IX. Peptides as nitrogen sources for the ericoid endophyte and for mycorrhizal and non-mycorrhizal plants. *New Phytologist* **101**: 459-467.
- Barak, P., Molina, J.A.E., Hadas, A. and Clapp, C.E. (1990) Mineralization of amino acids and evidence of direct assimilation of organic nitrogen. *Soil Science Society of America Journal* **54**: 769-774.
- Bazely, D.R. (1984) Responses of salt-marsh vegetation to grazing by lesser snow geese (*Anser caerulescens caerulescens*). MSc. thesis, Department of Botany, University of Toronto.
- Bazely, D.R. and Jefferies, R.L. (1985) Goose faeces: a source of nitrogen for plant growth in a grazed salt-marsh. *Journal of Applied Ecology* **22**: 693-703.
- Bazely, D.R. and Jefferies, R.L. (1989a) Lesser snow geese and the nitrogen economy of a grazed salt marsh. *Journal of Ecology* **77**: 24-34.
- Bazely, D.R. and Jefferies, R.L. (1989b) Leaf and shoot demography of an arctic stoloniferous grass, *Puccinellia phryganodes*, in response to grazing. *Journal of Ecology* **77**: 811-822.

Bazely, D.R. and Jefferies, R.L. (1996) Trophic Interactions in Arctic Ecosystems and the Occurrence of a Terrestrial Trophic Cascade. *Ecology of Arctic Environments* (eds S.J. Woodin and M. Marquiss), pp.183-207, Special Publication of the British Ecological Society, Blackwell Scientific Publications, Oxford.

Beevers, L. (1976) Nitrogen metabolism in plants. Edward Arnold Ltd., London.

Bidlingmeyer, B.A., Cohen, S.A., Tarvin, T.L. and Frost, B. (1987) A new, rapid, high-sensitivity analysis of amino acids in food type samples. *Journal of the Association of Analytical Chemistry* **70**: 241-247.

Bliss, L.C., Courtin, G.M., Pattie, D.L., Riewe, R.R., Whitfield, D.W.A. and Widden, P. (1973). Arctic tundra ecosystems. *Annual Review of Ecology and Systematics* **4**: 359-399

Block, R.J. (1956) Amino acid handbook; methods and results of protein analysis. Thomas, Springfield, IL.

Bloom, A.J. and Caldwell, R.M. (1988) Root excision decreases nutrient absorption and gas fluxes. *Plant Physiology* **87**: 794-796.

- Bollard, E.E. (1959) Utilisation of nitrogen and its compounds by plants. Symposium volume of the Society for Experimental Biology, no. XIII. Academic Press, New York.
- Boorer, K.J., Frommer, W.B., Bush, D.R., Kreman, M., Loo, D.F. and Wright, E.M. (1996) Kinetics and specificity of a H<sup>+</sup>/amino acid transporter from *Arabidopsis thaliana*. *Journal of Biological Chemistry* **271**: 2213-2220.
- Boorer, K.J. and Fischer, W.N. (1997) Specificity and stoichiometry of the *Arabidopsis* H<sup>+</sup>/amino acid transporter AAP5. *Journal of Biological Chemistry* **272**: 13040-13046.
- Bradley, P.M. and Morris, J.T. (1990) The influence of salinity on the kinetics of ammonium uptake in *Spartina alterniflora*. *Oecologia* **85**: 375-380.
- Britto, D.T., Siddiqi, M.Y., Glass, A.D.M. and Kronzucker, H.J. (2001) Futile transmembrane NH<sub>4</sub><sup>+</sup> cycling: A cellular hypothesis to explain ammonium toxicity in plants. *Proceedings of the National Academy of Sciences of the United States of America* **98**: 4255-4258.
- Brooks, P.D., Williams, M.W. and Schmidt, S.K. (1998) Inorganic nitrogen and microbial biomass dynamics before and during spring snowmelt. *Biogeochemistry* **43**: 1-15.

- Buchanan, B.B., Gruissem, W. and Jones, R.L. (2000) *Biochemistry and Molecular Biology of Plants*. American Society of Plant Physiologists, Rockville, Maryland.
- Cabrera, M.L. and Beare, M.H. (1993) Alkaline persulfate oxidation for determining total nitrogen in microbial biomass extracts. *Soil Science Society of America Journal* **57**: 1007-1012.
- Cain, M.L., Subler, S., Evans, J.P. and Fortin, M. (1999) Sampling spatial and temporal variation in soil nitrogen availability. *Oecologia* **118**: 397-404.
- Calvert, C.C., Klasing, K.C. and Austic, R.E. (1982) Involvement of food intake and amino acid catabolism in the branched-chain amino acid antagonism in chicks. *Journal of Nutrition* **112**: 627-635.
- Cargill, S.M. and Jefferies, R.L. (1984a) Nutrient limitation of primary production in a sub-arctic salt marsh. *Journal of Applied Ecology* **21**: 657-668.
- Cargill, S.M. and Jefferies, R.L. (1984b) The effects of grazing by lesser snow geese on the vegetation of a sub-arctic salt-marsh. *Journal of Applied Ecology* **21**: 669-686.
- Cerezo, M., Garcia-Agustin, P.G., Serna, M.D. and Primo-Millo, E. (1999) Kinetics of nitrate uptake by *Citrus* seedlings and inhibitory effects of salinity. *Plant Science* **126**: 105-112.

- Chalot, M. and Brun, A. (1998) Physiology of organic nitrogen acquisition by ectomycorrhizal fungi and ectomycorrhizas. *Federation of European Microbiological Societies Microbiology Reviews* **22**: 21-44.
- Chambers, R.M., Mozdzer, T.J. and Ambrose, J.C. (1998) Effects of salinity and sulfide on the distribution of *Phragmites australis* and *Spartina alterniflora* in a tidal saltmarsh. *Aquatic Botany* **62**: 161-169.
- Chapin, F.S. III. (1995) New cog in the nitrogen cycle. *Nature* **377**: 199-200.
- Chapin, D.M. and Bledsoe, C.S. (1992) Nitrogen Fixation in Arctic Plant Communities. In: *Arctic Ecosystems in a Changing Climate*. (eds F.S. Chapin III, R.L. Jefferies, J.F. Reynolds, G.R. Shaver, J. Svoboda), pp.301-319, Academic Press, San Diego, California.
- Chapin, F.S. III, Moilanen, L. and Kielland, K. (1993) Preferential use of organic nitrogen for growth by a non-mycorrhizal arctic sedge. *Nature* **361**: 150-153.
- Chapin, F.S. III, Van Cleve, K. and Tyron, P.R. (1986) Relationship of ion absorption to growth rate in taiga trees. *Oecologia* **69**: 238-242.

- Cherel, Y., Charrassin, J.B. and Challet, E. (1994) Energy and protein requirements for molt in the king penguin *Aptenodytes patagonicus*. *American Journal of Physiology* **266**: R1182-R1188.
- Clarkson, D.T. and Warner, A.J. (1979) Relationships between root temperature and the transport of ammonium and nitrate ions by italian and perennial ryegrass (*Lolium multiflorum* and *Lolium perenne*). *Plant Physiology* **64**: 557-561.
- Clarkson, D.T., Hopper, M.J. and Jones, L.H.P. (1986) The effect of root temperature on the uptake of nitrogen and the relative size of the root system in *Lolium perenne*. I. Solutions containing both  $\text{NH}_4^+$  and  $\text{NO}_3^-$ . *Plant, Cell & Environment* **9**: 535-545.
- Clarkson, D.T., Jones, L.H.P. and Purves, J.V. (1992) Absorption of nitrate and ammonium ions by *Lolium perenne* from flowing solution cultures at low root temperatures. *Plant, Cell & Environment* **15**: 99-106.
- Cooch, E.G., Lank, D.B., Rockwell, R.F. and Cooke, F. (1991) Long-term decline in body size in a snow goose population: evidence of environmental degradation? *Journal of Animal Ecology* **60**: 483-496.

- Cooch, E., Rockwell, R.F. and Brault, S. (2001) Retrospective analysis of demographic responses to environmental change: a lesser snow goose example. *Ecological Monographs* **71**: 377-400.
- Cornelissen, J.H.C., Callaghan, T.V., Alatalo, J.M., Michelsen, A., Graglia, E., Hartley, A.E., Hik, D.S., Hobbie, S.E., Press, M.C., Robinson, C.H., Henry, G.H.R., Shaver, G.R., Phoenix, G.K., Gwynn Jones, D., Jonasson, S., Chapin, F.S. III, Molau, U., Neill, C., Lee, J.A., Melillo, J.M., Sveinbjörnsson, B. and Aerts, R. (2001) Global change and arctic ecosystems: is lichen decline a function of increases in vascular plant biomass? *Journal of Ecology* **89**: 984-994.
- Cram, W.J. (1973) Internal factors regulating nitrate and chloride influx in plant cells. *Journal of Experimental Botany* **24**: 328-341.
- Deane-Drummond, C.E. and Glass, A.D.M. (1982) Studies of nitrate influx into barley roots by the use of  $^{36}\text{ClO}_3^-$  as a tracer for nitrate. I. Interactions with chloride and other ions. *Canadian Journal of Botany* **60**: 2147-2153.
- DeBusk, R.M., Brown, D.T., DeBusk, A.G. and Penderghast, R.D. (1981) Alternate mechanism for amino acid entry into *Neurospora crassa*: extracellular deamination and subsequent keto acid transport. *Journal of Bacteriology* **146**: 163-169.

Eisenthal, R. and Cornish-Brown, A. (1974) The direct linear plot. *Biochemical Journal*

**139**: 715-720.

Epstein, E. (1965) Mineral metabolism. In: *Plant Biochemistry*. (eds J. Bonner and J.E.

Varner), pp. 438-466, Academic Press, New York.

Epstein, E., Rains, D.W. and Elzam, W.E. (1963) Resolution of dual mechanisms of

potassium absorption by barley roots. *Proceedings of the National Academy of*

*Science* **49**: 684-692.

Epstein, E., Schmid, W.E. and Rains, D.W. (1963) Significance and technique of short-

term experiments on solute absorption by plant tissue. *Plant and Cell Physiology*

**4**: 79-84.

Falkengren-Grerup, U., Månsson, K.F. and M.O. Olsson. (2000) Uptake capacity of

amino acids by ten grasses and forbs in relation to soil acidity and nitrogen

availability. *Environmental and Experimental Botany* **44**: 207-219.

Fischer, W., André, B., Rentsch, D., Krolkiewicz, S., Tegeder, M., Breitzkreuz, K. and

Frommer, W.B. (1998) Amino acid transport in plants. *Trends in Plant Science* **3**:

188-195.

- Flowers, T.J., Troke, P.F. and Yeo, A.R. (1977) The mechanism of salt tolerance in halophytes. *Annual Review of Plant Physiology* **28**: 89.
- Fokin, A.D., Knyazev, D.A. and Kuzyakov, Y.V. (1993) Destruction of  $^{14}\text{C}$  and  $^{15}\text{N}$ -labeled amino acids and nucleic bases in soil and the supply of their transformation products to plants. *Eurasian Soil Science* **25**: 109-122.
- Francis, C.M. (2000) The relative impact of a spring hunt on Snow Goose population dynamics. *Population modelling and management of Snow Geese*. Occasional Paper Number **102**, Canadian Wildlife Service, Ottawa.
- Frommer, W.B., Hummel, S. and Riesmeier, J.W. (1993) Expression cloning in yeast of a cDNA encoding a broad specificity amino acid permease from *Arabidopsis thaliana*. *Proceedings of the National Academy of Sciences of the USA* **90**: 5944-5948.
- Frommer, W.B., Kwart, M., Hirner, B., Fischer, W.N., Hummel, S. and Ninnemann, O. (1994) Transporters for nitrogenous compounds in plants. *Plant Molecular Biology* **26**: 1651-1670.
- Frommer, W.B., Hummel, S., Unseld, M. and Ninnemann, O. (1995) Seed and vascular expression of a high affinity transporter for cationic amino acids in *Arabidopsis*. *Proceedings of the National Academy of Sciences of the USA* **92**: 12036-12040.

- Gadallah, F.L. and Jefferies, R.L. (1995) Forage quality in brood of the lesser snow goose and the growth of captive goslings. *Journal of Applied Ecology* **32**: 276-287.
- Giblin, A.E., Nadelhoffer, K.J., Shaver, G.R., Laundre, J.A. and McKerrow, A.J. (1991) Biogeochemical diversity along a riverside toposequence in arctic Alaska. *Ecological Monographs* **61**: 415-436.
- Glass, A.D.M., Erner, Y., Hunt, T., Kronzucker, H.J., Okamoto, M., Rawat, S., Silim, S., Schjoerring, J.K., Siddiqi, M.Y., Vidmar, J.J., Wang, M.Y. and Zhuo, D. (1999) Inorganic nitrogen absorption by plant roots: Physiology and Molecular Biology. In: Plant Nutrition - Molecular Biology and Genetics (eds. G. Gissel-Nielsen and A. Jensen), pp. 1-16. Kluwer Academic Publishers, Dordrecht, NL.
- Graglia, E., Jonasson, S., Michelsen, A., Schmidt, I.K., Havström, M. and Gustavsson, L. (2001) Effects of environmental perturbations on abundance of subarctic plants after three, seven and ten years of treatments. *Ecography* **24**: 5-12.
- Groffman, P.M., Zak, D.R., Christensen, S., Mosier, A. and Tiedje, J.M. (1993) Early spring nitrogen dynamics in a temperate forest landscape. *Ecology* **74**: 1579-1585.
- Grubb, T.C. (1989) Ptilochronology: feather growth bars as indicators of nutritional status. *Auk* **106**: 314-320.

- Hadas, A., Sofer, M., Molina, J.A.E., Barak, P. and Clapp, C.E. (1992) Assimilation of nitrogen by soil microbial population:  $\text{NH}_4^+$  versus organic N. *Soil Biology and Biochemistry* **24**: 137-143.
- Handa, I.T., Harmsen, R. and Jefferies, R.L. (2002) Patterns of vegetation change and the recovery potential of degraded areas in a coastal marsh system of the Hudson Bay lowlands. *Journal of Ecology* **90**: 86-99.
- Hanson, H.C. (1962) The dynamics of conditions factors in Canada geese and their relation to seasonal stresses. *Arctic Institute of North America Technical Paper* **12**.
- Hart, S.C., Stark, J.M., Davidson, E.A. and Firestone, M.K. (1994) Nitrogen mineralization, immobilization, and nitrification. In: *Methods of Soil Analysis. Part 2 - Microbiological and biochemical properties* (eds R.W. Weaver, J.S. Angle and P.S. Bottomley), pp. 985-1018. Soil Science Society of America, Madison, Wisconsin.
- Henry, H.A.L. and Jefferies, R.L. (2002) Free amino acid, ammonium and nitrate concentrations in soil solutions of a grazed coastal marsh in relation to plant growth. *Plant, Cell & Environment* **25**: 665-676.

- Henry, H.A.L. and Jefferies, R.L. (*in review*) Interactions in the uptake of amino acids, ammonium and nitrate ions in the arctic salt-marsh grass, *Puccinellia phryganodes*. *Plant, Cell & Environment*.
- Herring, G.M. (1973) The mucosubstances of bone. In: *Biological Mineralization* (ed. I. Zipkin), pp. 75-94. John Wiley and Sons, New York.
- Hik, D.S. and Jefferies, R.L. (1990) Increases in the net above-ground primary production of a salt-marsh forage grass: a test of the predictions of the herbivore-optimization model. *Journal of Ecology* **78**: 180-185.
- Hik, D.S., Jefferies, R.L. and Sinclair, A.R.E. (1992) Grazing by geese, isostatic uplift and the occurrence of multiple stable states of salt-marsh vegetation. *Journal of Ecology* **80**: 395-406.
- Hik, D.S., Sadul, H.A. and Jefferies, R.L. (1991) Effects of timing of multiple goose grazing by geese on net above-ground primary production of swards of *Puccinellia phryganodes*. *Journal of Ecology* **79**: 715-730.
- Hirner, B., Fischer, W.B., Rentsch, D., Kwart, M. and Frommer, W.B. (1998) Developmental control of H<sup>+</sup>/amino acid permease gene expression during seed development of *Arabidopsis*. *Plant Journal* **14**: 535-544.

Hoagland, D.R. and Arnon, D.I. (1950) The water-culture method of growing plants without soil. California Agricultural Experiment Station Circular **347**.

Hobbie, S.E. (1996) Temperature and plant species control over litter decomposition in Alaskan tundra. *Ecological Monographs* **66**: 503-522.

Hobbie, S.E. and Chapin, F.S. (1996) Winter regulation of tundra litter carbon and nitrogen dynamics. *Biogeochemistry* **35**: 327-338.

Hodge, A., Stewart, J., Robinson, D., Griffiths, B.S. and Fitter, A.H. (1998) Root proliferation, soil fauna and plant nitrogen capture from nutrient-rich patches in soil. *New Phytologist* **139**: 479-494.

Hodge, A., Stewart, J., Robinson, D., Griffiths, B.S. and Fitter, A.H. (1999) Plant, soil fauna and microbial responses to N-rich organic patches of contrasting temporal availability. *Soil Biology and Biochemistry* **31**: 1517-1530.

Hodge, A., Stewart, J., Robinson, D., Griffiths, B.S. and Fitter, A.H. (2000) Spatial and physical heterogeneity of N supply from soil does not influence N capture by two grass species. *Functional Ecology* **14**: 645-653.

Horton, H.R., Moran, L.A., Ochs, R.S., Rawn, J.D. and Scrimgeour, K.G. (1993) Principles of Biochemistry. Prentice-Hall, New Jersey.

- Hsu, L., Chiou, T., Chen, L. and Bush, D.R. (1993) Cloning a plant amino acid transporter by functional complementation of a yeast amino acid transport mutant. *Proceedings of the National Academy of Science of the USA* **90**: 7441-7445.
- Huang, Z., Yan, X., Jalil, A., Norlyn, J.D. and Epstein, E. (1992) Short-term experiments on ion transport by seedlings and excised roots. *Plant Physiology* **100**: 1914-1920.
- Hultén, E. (1968) Flora of Alaska and neighbouring territories. Stanford University Press, Stanford, CA.
- Iacobelli, A. and Jefferies, R.L. (1991) Inverse salinity gradients in coastal marshes and the death of stands of *Salix*: the effects of grubbing by geese. *Journal of Ecology*, **79**: 61-73.
- Ingestad, T. (1988) A fertilization model based on the concepts of nutrient flux density and nutrient productivity. *Scandinavian Journal of Forest Research* **3**: 157-173.
- Ingestad, T. and Lund, A.B. (1986) Theory and techniques for steady-state mineral nutrition and growth in plants. *Scandinavian Journal of Forest Research* **1**: 439-453.

- Intergovernmental Panel on Climate Change (IPCC) (2001) *Climate Change 2001: The scientific basis*. J.T. Houghton, Y. Ding, D.J. Griggs, M. noguer, P.J. van der Linden, X. Dai, K. Maskell and C.A. Johnson (eds.). Cambridge University Press, Cambridge.
- Ivarson, K.L. and Sowden, F.J. (1970) Effect of frost action and storage of soil at freezing temperatures on the free amino acids, free sugars and respiratory activity of soil. *Canadian Journal of Soil Science* **50**: 191-198.
- Jackson, L.E., Schimel, J.P. and Firestone, M.K. (1989) Short-term partitioning of ammonium and nitrate between plants and microbes in an annual grassland. *Soil Biology and Biochemistry* **21**: 409-415.
- Jackson, R.B. and Caldwell, M.M. (1993) The scale of nutrient heterogeneity around individual plants and its quantification with geostatistics. *Ecology* **74**: 612-614.
- Jaeger III, C.H., Monson, R.K., Fisk, M.C. and Schmidt, S.K. (1999) Seasonal partitioning of nitrogen by plants and soil microorganisms in an alpine ecosystem. *Ecology* **80**: 1883-1891.
- Jano, A.P., Jefferies, R.L. and Rockwell, R.F. (1998) The detection of vegetational change by multitemporal analysis of LANDSAT data: the effects of goose foraging. *Journal of Ecology* **86**: 93-99.

- Jefferies, R.L. (1988a) Pattern and process in arctic coastal vegetation in response to foraging by lesser snow geese. In: *Plant Form and Vegetation Structure* (eds M.J.A. Werger, P.J.M. van der Aart, H.J. During and J.T.A. Verhoeven), pp. 281-300. SPB Academic Publishing, The Hague.
- Jefferies, R.L. (1988b) Vegetational mosaics, plant-animal interactions and resources for plant growth. In: *Plant Evolutionary Biology* (eds L.D. Gottlieb and S.K. Jain), pp. 341-369. Chapman & Hall, London.
- Jefferies, R.L., Henry, H. and Abraham, K.F. (2002) Agricultural nutrient subsidies to migratory geese and ecological change to Arctic coastal habitats. *Food Webs at the Landscape Level* (eds G.Huxel and M.E.Power), University of Chicago Press, Chicago (in press).
- Jefferies, R.L., Klein, D.R. and Shaver, G.R. (1994) Herbivory and northern plant communities: reciprocal influences and responses. *Oikos* **71**: 193-206.
- Jefferies, R.L. and Rockwell, R.F. (2002) Foraging geese, vegetation loss and soil degradation in an Arctic salt marsh. *Applied Vegetation Science* **5**: 7-16.

- Johnson, I.R. and Parsons, A.J. (1985) Use of a model to analyse the effects of continuous grazing managements on seasonal patterns of grass production. *Grass and Forage Science* **40**: 449-458.
- Jones, D.L. 1999. Amino acid biodegradation and its potential effects on organic nitrogen capture by plants. *Soil Biology and Biochemistry* **31**: 613-622.
- Jones, D.L. and Darrah, P.R. (1994) Amino acid influx at the soil-root interface of *Zea mays* L. and its implications in the rhizosphere. *Plant and Soil* **163**: 1-12.
- Jones, D.L. and Hodge, A. (1999) Biodegradation kinetics and sorption reactions of three differently charged amino acids in soil and their effects on plant organic nitrogen availability. *Soil Biology and Biochemistry* **31**: 1331-1342.
- Jones, D.L. and Kielland, K. (2002) Soil amino acid turnover dominates the nitrogen flux in permafrost-dominated taiga forest soils. *Soil Biology and Biochemistry* **34**: 209-219.
- Kaye, J.P. and Hart, S.C. (1997) Competition for nitrogen between plants and soil microorganisms. *Trends in Ecology and Evolution* **12**: 139-143.
- Keeney, D.R. and Nelson, D.W. (1982) Nitrogen-inorganic forms. In: Methods of soil analysis. Part 2, 2<sup>nd</sup> edition, Agronomy Monograph 9 (ed. A.L. Page), pp. 643-

698. American Society of Agronomy and Soil Science Society of America,  
Madison, WI.

Kershaw, K.A. (1976) The vegetational zonation on the East Pen Island salt marshes,  
Hudson Bay. *Canadian Journal of Botany* **54**: 5-13.

Kielland K. (1994) Amino acid absorption by arctic plants: implications for plant  
nutrition and nitrogen cycling. *Ecology* **75**: 2373-2383.

Kielland K. (1995) Landscape patterns of free amino acids in arctic tundra soils.  
*Biogeochemistry* **31**: 85-98.

Kielland, K. and Chapin, F.S. (1992) Nutrient absorption and accumulation in arctic  
plants. In: Arctic Ecosystems in a Changing Climate. An Ecophysiological  
Perspective (eds F.S. Chapin, R.L. Jefferies, J.F. Reynolds, G.R. Shaver and J.  
Svoboda), pp. 281-300. Academic Press Inc., San Diego.

King, J.R. and Murphy, M.E. (1984) Fault bars in the feathers of white-crowned  
sparrows: dietary deficiency or stress of captivity and handling. *Auk* **101**: 168-  
169.

Klasing, K.C. (1998) Comparative Avian Nutrition. CAB International, New York.

- Kotanen, P.M. (2002) Constraints on nutrient cycling in fresh-water arctic ecosystem grazed by snow geese: the role of mosses. *Arctic and Alpine Research* **34**: 219-225.
- Krapu, G.L. and Reinecke, K.J. (1992) Foraging ecology and nutrition. In: Ecology and Management of Breeding Waterfowl (eds B.D.J. Batt, A.D. Afton, M.G. Anderson, C.D. Ankney, D.H. Johnson, J.A. Kadlec and G.L. Krapu), pp. 1-29. University of Minnesota Press, Minneapolis.
- Kronzucker, H.J., Glass, A.D.M. and Siddiqi, M.Y. (1999) Inhibition of nitrate uptake by ammonium in barley. Analysis of component fluxes. *Plant Physiology* **120**: 283-291.
- Kronzucker, H.J., Siddiqi, M.Y. and Glass, A.D.M. (1995) Kinetics of  $\text{NO}_3^-$  influx in spruce. *Plant Physiology* **109**: 319-326.
- Kronzucker, H.J., Siddiqi, M.Y. and Glass, A.D.M. (1996) Kinetics of  $\text{NH}_4^+$  influx in spruce. *Plant Physiology* **110**: 773-779.
- Kronzucker, H.J., Siddiqi, M.Y. and Glass, A.D.M. (1997) Conifer root discrimination against soil nitrate and the ecology of forest succession. *Nature* **385**: 59-61.

Kwart, M., Hirner, B., Hummel, S. and Frommer, W.B. (1993) Differential expression of two related amino acid transporters with differing substrate specificity in *Arabidopsis thaliana*. *Plant Journal* **4**: 993-1002.

Lawes, J.B. and Gilbert, J.H. (1881) On the amount and composition of the rain and drainage waters collected at Rothamstead. Part II. The amount and composition of the drainage waters from unmanured fallow land. *Journal of the Royal Agricultural Society of England* **17**: 311-350.

Lea, P.J. and Ireland, R.J. (1999) Nitrogen Metabolism in higher plants. In: *Plant Amino Acids. Biochemistry and Biotechnology* (ed. B.K. Singh), pp. 1-48. Marcel Dekker, New York.

Leadley, P.W., Reynolds, J.F. and Chapin, F.S. III. (1997) A model of nitrogen uptake by *Eriophorum vaginatum* roots in the field: ecological implications. *Ecological Monographs* **67**: 1-22.

Lee, C. (1988) Amino acid and amine biogeochemistry in marine particulate material and sediment. In: *Nitrogen cycling in Coastal Marine Environments* (eds T.H. Blackburn and J. Sørensen), pp. 125-141. Wiley, New York.

- Lee, J.A. (1999) Arctic plants: adaptations and environmental change. In: Physiological Plant Ecology (eds M.C. Press, J.D. Scholes and M.G. Barker), pp. 313-330. Blackwell Science, London.
- Lee, R.B. (1982) Selectivity and kinetics of ion uptake by barley plants following nutrient deficiency. *Annals of Botany* **50**: 429-449.
- Lee, R.B. and Rudge, K.A. (1986) Effects of nitrogen deficiency on the absorption of nitrate and ammonium by barley plants. *Annals of Botany* **57**: 471-486.
- Li, Z. and Bush, D.R. (1990) pH-dependent amino acid transport into plasma membrane vesicles isolated from sugar beet leaves. *Plant Physiology* **94**: 268-277.
- Li, Z. and Bush, D.R. (1991) pH-dependent amino acid transport into plasma membrane vesicles isolated from sugar beet (*Beta vulgaris* L.) leaves. *Plant Physiology* **96**: 1338-1344.
- Li, Z. and Bush, D.R. (1992) Structural determinants in substrate recognition by proton-amino acid symporters in plasma membrane vesicles isolated from sugar beet leaves. *Archives of Biochemistry and Biophysics* **294**: 519-526.

- Lipson, D.A. and Monson, R.K. 1998. Plant-microbe competition for soil amino acids in the alpine tundra: effects of freeze-thaw and dry-rewet events. *Oecologia* **113**: 406-414.
- Lipson, D.A. and Näsholm, T. (2001) The unexpected versatility of plants: organic nitrogen use and availability in terrestrial ecosystems. *Oecologia* **128**: 305-316.
- Lipson, D.A., Raab, T.K., Schmidt, S.K. and Monson, R.K. (1999) Variation in competitive abilities of plants and microbes for specific amino acids. *Biology and Fertility of Soils* **29**: 257-261.
- Lipson, D.A., Raab, T.K., Schmidt, S.K. and R.K. Monson. (2001) An empirical model of amino acid transformations in an alpine soil. *Soil Biology and Biochemistry* **33**: 189-198.
- Loeppert, R.H. and Inskeep, W.P. (1996) Iron. In: Methods of Soil Analysis. Part 3 - Chemical Methods (ed. D.L. Sparks), pp. 639-664. Soil Science Society of America, Madison, Wisconsin.
- Martens, D.A. and Frankenberger, W.T. (1993) Stability of microbial-produced auxins derived from L-tryptophan added to soil. *Soil Science* **155**: 263-271.

- Martin, M.M. and Kukor, J.J. (1984) Role of mycophagy and bacteriophagy in invertebrate nutrition. Pgs 257-263 in M.J. Klug and C.A. Reddy, eds. *Current Perspectives in Microbial Ecology*. American Society of Microbiology, Washington DC.
- Martini, I.P. (1982) Geomorphological features on the Ontario coast of the Hudson Bay. *Naturaliste canadien* **109**: 415-429.
- McBride, M.B. (1989) Surface chemistry of soil minerals. In: *Minerals in Soil Environments* (eds J.B. Dixon and S.B. Weed), pp. 35-88. Soil Science Society of America, Madison, Wisconsin.
- McClung, G. and Frankenberger, W.T. (1985) Soil nitrogen transformations as affected by salinity. *Soil Science* **139**: 405-411.
- McKane, R.B., Johnson, L.C., Shaver, G.R., Nadelhoffer, K.J., Rastetter, E.B., Fry, B., Giblin, A.E., Kielland, K., Kwiatkowski, B.L., Laundre, J.A. and Murray, G. (2002) Resource-based niches provide a basis for plant species diversity and dominance in arctic tundra. *Nature* **415**: 68-71.
- Mengel, K. (1996) Turnover of organic nitrogen in soils and its availability to crops. *Plant and Soil* **181**: 83-93.

- Miettinen, K.J. (1959) Assimilation of amino acids in higher plants. In: Symposium of the Society of Experimental Biology 13, pp. 210-230. Academic Press, New York.
- Min, X., Siddiqi, M.Y., Guy, R.D., Glass, A.D.M. and Kronzucker, H.J. (1999) A comparative study of fluxes and compartmentation of nitrate and ammonium in early-successional tree species. *Plant, Cell and Environment* **22**: 821-830.
- Mitchell, H.H. (1959) Some species and age differences in amino acid requirements. In: *Protein and Amino Acid Nutrition* (ed. A.A. Albanese), pp. 11-43. Academic Press, New York.
- Mitchell, H.H. (1964) *Comparative Nutrition of Man and Domestic Animals*. Academic Press, New York.
- Mopper, K and Zika, R.G. (1987) Free amino acids in marine rains: evidence for oxidation and potential role in nitrogen cycling. *Nature* **325**: 246-249.
- Morgan, M.A. and Jackson, W.A. (1988) Inward and outward movement of ammonium in roots systems: transient responses during recovery from nitrogen deprivation in presence of ammonium. *Journal of Experimental Botany* **39**: 197-191.

- Munoz-Blanco, J., Hidalgo-Martínez and Cárdenas, J. (1990) Extracellular deamination of L-amino acids by *Chlamydomonas reinhardtii* cells. *Planta* **182**: 194-198.
- Murphy, D.V., Macdonald, A.J., Stockdale, E.A., Goulding, K.W.T., Fortune, S., Gaunt, J.L., Poulton, P.R., Wakefield, J.A., Webster, C.P. and Wilmer, W.S. (2000) Soluble organic nitrogen in agricultural soils. *Biology and Fertility of Soils* **30**: 374-387.
- Murphy, M.E., King, J.R., Taruscio, T.G. and Geupel, G.R. (1990) Amino acid composition of feather barbs and rachises in three species of pygoscelid penguins: nutritional implications. *Condor* **92**: 913-921.
- Nadelhoffer, K.J., Giblin, A.E., Shaver, G.R. and Laundre, J.A. (1991) Effects of Temperature and Substrate Quality on Element Mineralization in Six Arctic Soils. *Ecology* **72**: 242-253.
- Nadelhoffer, K.J., Giblin, A.E., Shaver, G.R. and Linkins, A.E. (1992) Microbial processes and plant nutrient availability in arctic soils. In: *Arctic Ecosystems in a Changing Climate. An Ecophysiological Perspective* (eds F.S. Chapin III, R.L. Jefferies, J.F. Reynolds, G.R. Shaver and J. Svoboda), pp. 281-300. Academic Press Inc., San Diego.

- Näsholm, T., Ekblad, A., Nordin, A., Giesler, R., Hogberg, M. and Högberg, P. (1998) Boreal forest plants take up organic nitrogen. *Nature* **392**: 914-916.
- Näsholm, T., K. Huss-Danell and P. Högberg. (2000) Uptake of organic nitrogen in the field by four agriculturally important plant species. *Ecology* **81**:1155-1161.
- Näsholm T., Huss-Danell K. and Högberg P. (2001) Uptake of glycine by field grown wheat. *New Phytologist* **150**: 59-63.
- Näsholm, T. and Persson, J. (2001) Plant acquisition of organic nitrogen in boreal forests. *Physiologia Plantarum* **111**: 419-426.
- Nelson, D.W. and Sommers, L.E. (1996) Total carbon, organic carbon, and organic matter. In: *Methods of Soil Analysis. Part 3 - Chemical methods* (ed. D.L. Sparks), pp. 961-1010. Soil Science Society of America, Madison, Wisconsin.
- Nordin, A., Högberg, P. and Näsholm, T. (2001) Soil nitrogen form and plant nitrogen uptake along a boreal forest productivity gradient. *Oecologia* **129**: 125-132.
- Norton, J.M. and Firestone, M.K. (1996) N dynamics in the rhizosphere of *Pinus ponderosa* seedlings. *Soil Biology and Biochemistry* **28**: 351-362.

Noy-Meir, I. (1975) Stability of grazing systems: an application of predator-prey graphs.

*Journal of Ecology* **63**: 459-481.

Nye, P.H. (1969) The soil model and its application to plant nutrition. In: Ecological

Aspects of the Mineral Nutrition of Plants (ed. I.H. Rorison), pp. 105-114.

Blackwell Scientific Publications, Oxford.

Nye, P.H. (1981) Changes in pH across the rhizosphere induced by roots. *Plant and Soil*

**61**: 7-26.

Nye, P.H. and Tinker, P.B. (1977) Solute Movement in the Soil-Root System. Blackwell

Scientific Publications, Oxford.

Owen, A.G. and D.L. Jones. (2001) Competition for amino acids between wheat roots

and rhizosphere microorganisms and the role of amino acids in plant N

acquisition. *Soil Biology and Biochemistry* **33**: 651-657.

Parton, W.J., Schimel, D.S., Cole, C.V. and Ojima, D.S (1967) Analysis of factors

controlling soil organic matter levels in Great Plains grasslands. *Soil Science*

*Society of America* **51**: 1173-1179.

- Pastor, J., Dewey, B., Moen, R., Mladenoff, D.J., White, M. and Cohen, Y. (1998)  
Spatial patterns in the moose-forest ecosystem on Isle Royale, Michigan, USA.  
*Ecological Applications* **8**: 411-424.
- Pate, J. (1986) Economy of symbiotic nitrogen function. In: On the economy of plant  
form and function (ed. T.J. Givnish), pp. 299-325. Cambridge University Press,  
Cambridge.
- Pate, J.S. and Layzell, D.B. (1990) Energetics and biological costs of nitrogen  
assimilation. In: The Biochemistry of Plants (eds P.K. Stumpf and E.E. Conn), pp.  
1-42. Academic Press, San Diego, California.
- Paul, E.A. and Clark, F.E. (1989) *Soil Microbiology and Biochemistry*. Academic Press,  
San Diego, California.
- Paul, E.A. and Juma, N. G. (1981) Mineralization and immobilization of soil nitrogen by  
microorganisms. In: Terrestrial Nitrogen Cycles: Processes, Ecosystem Strategies  
and Management Impacts. Ecological Bulletin No. 33 (eds F.E. Clark and T.  
Rosswall), pp. 179-200. Swedish Natural Science Research Council, Stockholm..
- Paul, J.H. and Cooksey, K.E. (1979) Asparagine metabolism and asparaginase activity in  
euhaline *Chlamydomonas* species. *Canadian Journal of Microbiology* **25**:  
1443-1451.

- Paul, J.H. and Cooksey, K.E. (1981) Regulation of L-asparaginase in a *Chlamydomonas* species in response to ambient concentrations of combined nitrogen. *Journal of Bacteriology* **148**: 9-12.
- Pearson, J. and Stewart, G.R. (1993) The deposition of atmospheric ammonia and its effects on plants. *New Phytologist* **125**: 283-305.
- Perakis, S.S. and Hedin, L.O. (2002) Nitrogen loss from unpolluted South American forests mainly via dissolved organic compounds. *Nature* **415**: 416-419.
- Persson, J. and Näsholm, T. (2001) Amino acid uptake: a widespread ability among boreal forest plants. *Ecology Letters* **4**: 434-438.
- Porsild, A.E. and Cody, W.J. (1980) Vascular plants of Northwest Territories, Canada. National Museum of Canada, Ottawa.
- Prins, H.H.T., Ydenberg, R.C. and Drent, R.H. (1980) The interaction of Brent geese, *Branta bernicla*, and sea plantain, *Plantago maritima*, during spring staging: Field observations and experiments. *Acta Botanica Neerlandica* **29**: 585-596.
- Prop, J. and Black, J.M. (1998) Food intake, body reserves and reproductive success of barnacle geese *Branta leucopsis* staging in different habitats. Research on arctic

geese. (eds F. Mehlum, J.M.Black and J.Madsen), pp. 175-194, Proceedings of the Svalbard Goose Symposium, Oslo, Norway, 23-26 September 1997, Norsk Polarinstitut, Oslo.

Raab, T.K., Lipson, D.A. and Monson, R.K. (1996) Non-mycorrhizal uptake of amino acids by roots of the alpine sedge *Kobresia myosuroides*: implications for the alpine nitrogen cycle. *Oecologia* **108**: 488-494.

Raab, T.K., Lipson, D.A. and Monson, R.K. (1999) Soil amino acid utilization among species of the Cyperaceae: plant and soil processes. *Ecology* **80**: 2408-2419.

Raber, B., Kögel-Knabner, I., Steen, C. and Klem, D. (1998) Partitioning of polycyclic aromatic hydrocarbons to dissolved organic matter from different soils. *Chemosphere* **36**: 79-97.

Rastetter, E.B., Ryan, M.G., Shaver, G.R., Melillo, J.M., Nadelhoffer, K.J., Hobbie, J.E. and Aber, J.D. (1991) A general biogeochemical model describing the response of the C and N cycles in terrestrial ecosystems to changes in CO<sub>2</sub>, climate and N deposition. *Tree Physiology* **9**: 101-126.

Reiners, W.A. (1986) Complementary Models for Ecosystems. *American Naturalist* **127**: 59-73.

- Reinhold, L. and Kaplan, A. (1984) Membrane-transport of sugars and amino acids. *Annual Review of Plant Physiology* **35**: 45-83.
- Rentsch, D., Hirner, B., Schmelzer, E. and Frommer, W.B. (1996) Salt stress-induced proline transporters and salt stress-repressed broad specificity amino acid permeases identified by suppression of a yeast amino acid permease-tageting mutant. *Plant Cell* **8**: 1437-1446.
- Rietkerk, M. and van de Koppel, J. (1997) Alternate stable states and threshold effects in semi-arid grazing systems. *Oikos* **79**: 69-76.
- Risser, P.G. and Parton, W.J. (1982) Ecosystem analysis of the tallgrass prairie; nitrogen cycle. *Ecology* **63**: 1342-1351.
- Ross, D.J. (1992) Influence of sieve mesh size on estimates of microbial carbon and nitrogen by fumigation-extraction procedures in soils under pasture. *Soil Biology and Biochemistry* **24**: 343-350.
- Rowntree, P.R. (1997) Global and regional patterns of climate change: recent predictions for the Arctic. In: *Global Change and Arctic Terrestrial Systems* (eds W.C. Oechel, T. Callahan and T. Gilmanov), pp. 82-109. Springer, Berlin.

- Ruess, R.W., Hik, D.S. and Jefferies, R.L. (1989) The role of lesser snow geese as nitrogen processors in a sub-arctic salt marsh. *Oecologia* **79**: 23-29.
- Rustad, L.E., Campbell, J.L., Marion, G.M., Norby, R.J., Mitchell, M.J., Hartley, A.E., Cornelissen, J.H.C., Gurevitch, J and GCTE-NEWS (2001) A meta-analysis of the response of soil respiration, net nitrogen mineralization, and aboveground plant growth to experimental ecosystem warming. *Oecologia* **126**: 543-562.
- Schimel, J. P. and Chapin, F.S. III. (1996) Tundra plant uptake of amino acid and  $\text{NH}_4^+$  nitrogen in situ: plants compete well for amino acid N. *Ecology* **77**: 2142-2147.
- Schimel, J.P., Jackson, L.E. and Firestone, M.K. (1989) Spatial and temporal effects on plant-microbial competition for inorganic nitrogen in a California annual grassland. *Soil Biology and Biochemistry* **21**: 1059-1066.
- Schmidt, S. and Stewart, G.R. (1997) Waterlogging and fire impact on nitrogen availability and utilization in a subtropical wet heathland (wallum). *Plant, Cell and Environment* **20**:1231-1241.
- Schmidt, S. and Stewart, G.R. (1999) Glycine metabolism by plant roots and its occurrence in Australian plan communities. *Australian Journal of Plant Physiology* **26**: 253-264.

Schobert, C., Kockenberger, W. and Komor, E. 1988. Uptake of amino acids by plants from the soil: a comparative study with castor bean seedlings grown under natural and axenic soil conditions. *Plant and Soil* **109**: 181-188.

Schobert, C. and Komor, E. (1987) Amino acid uptake by *Ricinus communis* roots: characterization and physiological significance. *Plant, Cell & Environment* **10**: 493-500.

Schulten, H.R. and Schnitzer, M. (1998) The chemistry of soil organic nitrogen: a review. *Biology and Fertility of Soils* **26**: 1-15.

Seagle, S.W., McNaughton, S.J. and Ruess, R.W. (1992) Simulated effects of grazing on soil nitrogen and mineralization in contrasting Serengeti grasslands. *Ecology* **73**: 1105-1123.

Shaver, G.R. and Chapin, F.S. III. (1986) Effect of fertilizer on production and biomass of tussock tundra, Alaska, USA. *Arctic and Alpine Research* **18**: 261-268.

Shaver, G.R., Bret-Harte, M.S., Jones, M.H., Johnstone, J., Gough, L., Laundre, J. and Chapin, F.S. III. (2001) Species composition interacts with fertilizer to control long-term change in tundra productivity. *Ecology* **82**: 3163-3181.

- Siddiqi M.Y., Glass A.D.M., Ruth T.J. and Rufty T.W. (1990) Studies of the uptake of nitrate in barley. I. Kinetics of  $^{13}\text{NO}_3^-$  influx. *Plant Physiology* **93**: 1426-1432.
- Skinner, W.R., Jefferies, R.L., Carleton, T.J., Rockwell, R.F. and Abraham, K.R. (1998) Prediction of reproductive success and failure in lesser snow geese based on early season climatic variables. *Global Change Biology* **4**: 3-16.
- Skogland T., Lomeland S. and Goksoyr J. (1988) Respiratory burst after freezing and thawing of soil: experiments with soil bacteria. *Soil Biology and Biogeochemistry* **20**: 851-856.
- Soldal, T. and Nissen, P. (1978) Multiphasic uptake of amino acids by barley roots. *Physiologia Plantarum* **43**: 181-188.
- Solorzano L. (1969) Determination of ammonia in natural waters by the phenol-hypochlorite method. *Limnology and Oceanography* **14**: 799-801.
- Sowden F.J., Chen Y. and Schnitzer M. (1977) The nitrogen distribution in soils formed under widely differing climatic conditions. *Geochimica et Cosmochimica Acta* **41**: 1524-1526.
- Sprent, J.I. (1987) *The Ecology of the Nitrogen Cycle*. Cambridge University Press, Cambridge.

- Srivastava, D.S. and Jefferies, R.L. (1995) The effect of salinity on the leaf and shoot demography of 2 arctic forage species. *Journal of Ecology* **83**: 421-430.
- Srivastava, D.S. and Jefferies, R.L. (1996) A positive feedback: herbivory, plant growth, salinity and the desertification of an arctic salt marsh. *Journal of Ecology* **84**: 31-42.
- Stark, J.M. and Hart, S.C. (1996) Diffusion technique for preparing salt solutions, Kjeldahl digests, and persulfate digests for nitrogen-15 analysis. *Soil Science Society of America Journal* **60**: 1846-1855.
- Stewart, G.R. and Lee, J.A. (1974) The role of proline accumulation in halophytes. *Planta* **120**: 279-289.
- Streeter, T.C., Bol, R. and R.D. Bardgett. (2000) Amino acids as a nitrogen source in temperate upland grasslands: the use of dual labelled ( $^{13}\text{C}$ ,  $^{15}\text{N}$ ) glycine to test for direct uptake by dominant grasses. *Rapid Communications in Mass Spectrometry* **14**: 1351-1355.
- Stribley, D.P. and Read, D.J. (1980) The biology of mycorrhiza in the Ericaceae. VII The relationship between mycorrhizal infection and the capacity to utilize simple and complex organic nitrogen sources. *New Phytologist* **86**: 365-371.

Sundell, N.M., Cooch, E.G. and Durrett, R.T. (200N) Dynamics of a two patch herbivory system: herbivore enhancement, adaptive behaviour and trophic cascades.

*Theoretical Population Biology* (in review).

Thornley, J.H.M. and Cannell, M.G.R. (2000) dynamics of mineral N availability in grassland ecosystems under increased [CO<sub>2</sub>]: hypotheses evaluated using the Hurley Pasture Model. *Plant and Soil*, **224**: 153-170.

Thornton, B. (2001) Uptake of glycine by non-mycorrhizal *Lolium perenne*. *Journal of Experimental Botany* **52**: 1315-1322.

Tinker, P.B. (1969) The transport of ions in the soil around plant roots. In: Ecological Aspects of the Mineral Nutrition of Plants (ed. I.H. Rorison), pp. 149-154. Blackwell Scientific, Oxford.

Tukey, J. (1953) A Problem of Multiple Comparisons. Princeton University, New Jersey.

Turnbull, M.H., Goodall, R. and Stewart, G.R. (1995) The impact of mycorrhizal colonization upon nitrogen source utilization and metabolism in seedlings of *Eucalyptus grandis* Hill ex Maiden and *Eucalyptus maculata* Hook. *Plant Cell and Environment* **18**: 1386-1394.

Turnbull, M.H., Schmidt, S., Erskine, P.D., Richards, S. and Stewart, G.R. (1996) Root adaptation and nitrogen source acquisition in natural ecosystems. *Tree Physiology* **16**: 941-948.

Ulrich, A. and Gersper, P.L. (1978) Plant nutrient limitations of tundra plant growth. In: *Vegetation and Production Ecology of an Alaskan Tundra* (ed. L.L. Tieszen), pp.457-481, Ecological Studies 29, Springer Verlag, Berlin.

Uren, N.C. (2001) Types, amounts, and possible functions of compounds released into the rhizosphere by soil-grown plants. In: *The Rhizosphere* (eds R. Pinton, Z. Varanini and P. Nannipieri), pp. 19-40. Marcel Dekker, Inc., New York.

van Breeman, N. (2002) Natural organic tendency. *Nature* **415**: 381-382.

Van Cleve, K. (1973) Revegetation of disturbed tundra and taiga surfaces by introduced and native plant species. *Proceedings of the Symposium of Oil Resource Development and its Impact on Northern Plant Communities. Occasional Publications on Northern Life*, No.1, pp.7-11, University of Alaska, Fairbanks.

Van de Koppel, J., Rietkerk, J.M. and Weissing, F.J. (1997) Catastrophic vegetation shifts and soil degradation in terrestrial grazing systems. *Trends in Ecology and Evolution* **12**: 352-356.

- Van de Koppel, J., Herman, P.M.J., Thoolen, P. and Heip, C.H.R. (2001) Do alternate stable states occur in natural ecosystems? Evidence from a tidal flat. *Ecology* **82**: 3449-3461.
- Vance, E.D., Brookes, P.C. and Jenkinson, D.S. (1987) An extraction method for measuring soil microbial biomass C. *Soil Biology and Biochemistry* **19**: 703-707.
- Vinolas, L.C., Healey, J.R. and Jones, D.L. (2001) Kinetics of soil microbial uptake of free amino acids. *Biology and Fertility of Soils* **33**: 67-74.
- Vinolas, L.C., Vallejo, V.R. and Jones, D.L. (2001) Control of amino acid mineralization and microbial metabolism by temperature. *Soil Biology and Biochemistry* **33**, 1137-1140.
- Virtanen, A.I. and Linkola, H. (1946) Organic nitrogen compounds as nitrogen nutrition for higher plants. *Nature* **157**: 515.
- Vitousek, P.M. (1994) Beyond global warming: Ecology and global change. *Ecology* **75**: 1861-1876.
- Wallenda, T. and Read, D.J. (1999) Kinetics of amino acid uptake by ectomycorrhizal roots. *Plant, Cell and Environment* **22**: 179-187.

- White T.C.R. 1993. *The Inadequate Environment - Nitrogen and the abundance of animals*. Springer-Verlag, New York.
- Wilson, D.J. (1993) *Nitrogen mineralization in a sub-arctic salt marsh*. MSc Thesis, University of Toronto, Toronto.
- Wilson, D.J. and Jefferies, R.L. (1996) Nitrogen mineralization, plant growth and goose herbivory in an Arctic coastal ecosystem. *Journal of Ecology* **84**, 841-851.
- Wilson D.J., van der Wal R., Chang E.R., Jensen A. and Jefferies R.L. (1999) Urea hydrolysis and nitrification in arctic salt-marsh soils: Possible constraints on the growth of forage plants. *Ecoscience* **6**, 72-78.
- Witt, C., Gaunt, J.L., Galicia, C.C., Ottow, J.C.G. and Neue, H. (2000) A rapid chloroform-fumigation extraction method for measuring soil microbial biomass carbon and nitrogen in flooded rice soils. *Biology and Fertility of Soils* **30**: 510-519.
- Wolt, J.D. (1994) *Soil Solution Chemistry*. John Wiley and Sons, New York.
- Xu, G., Magen, H., Tarchitzky, J. and Kafkafi, U. (2000) Advances in chloride nutrition of plants. *Advances in Agronomy* **68**: 98-150.

Zak, D.R., Groffman, P.M., Pregitzer, K.S., Christensen, S. and Tiedje, J.M. (1990) The vernal dam: plant-microbe competition for nitrogen in northern hardwood forests. *Ecology* **71**: 651-656.